

Medieval Costume in England and France

The 13th, 14th and 15th Centuries

Mary G. Houston

This carefully researched volume offers lovers of both costume and the medieval period a meticulously researched and accurately detailed study of the clothing of the Middle Ages. Following an illuminating discussion of the style and construction of costumes worn in the 13th, 14th and 15th centuries, noted costume historian Mary G. Houston provides detailed descriptions and illustrations of actual apparel worn by all classes and sectors of society. Included are elaborate royal, academic and legal costumes; eucharistic vestments and garments of religious orders; working class apparel, civilian dress and more. Also examined is a wide variety of accessories and ornaments, jewelry, armor, textiles, embroidery, cufflers and other items.

The clear, succinct text is splendidly documented by 350 black and white line illustrations based on contemporary books and manuscripts as well as reproductions in paintings and sculpture. Indispensable for students of costume history, medievalists, illustrators and fashion historians, *Medieval Costume in England and France* will delight anyone interested in the medieval period and its dress.

Unabridged Dover (1990) republication of the work published by Adam & Charles Black, London, 1939. Introduction. Glossary of Medieval Terms for Costumes. Bibliography. 350 black and white line illustrations. 9 color illustrations on the covers. 256pp. 5 1/2" x 9 1/4" Paperbound

ALSO AVAILABLE

AUTHENTIC EVERYDAY DRESS OF THE RENAISSANCE. ALL 154 PLATES FROM THE "TRACHTENBUCH," Christoph Weiditz. 144pp. 9 1/2" x 12 1/2" \$7.95 Pk. \$11.95

EUROPEAN COSTUME OF THE SIXTEENTH THROUGH EIGHTEENTH CENTURIES IN PINK. COLOR: 150 ILLUSTRATIONS, Edmond Lechevalier (Chevalier). 28pp. 9 1/2" x 12 1/2" 28519-7 Pk. \$17.95

RACINET'S FULL-COLOR PICTORIAL HISTORY OF WESTERN CIVILIZED WOMEN IN PINK. SHOWING OVER 950 AUTHENTIC COSTUMES FROM THE MIDDLE AGES TO 1880, Auguste Racinet. 92pp. 9 1/2" x 12 1/2" 25494 X Pk. \$13.95

Free Dover Complete Catalog (50099-0) available upon request.

ISBN 0-486-29060-3



0 780486 29060 3

PUBLISHED BY DOVER
NONNET, IN USA

Medieval Costume in England and France

The 13th, 14th and 15th Centuries

Mary G. Houston



With 350 Illustrations

Dover Publications, Inc., 180 Varot Street, Dover, N.J. 07801
Dover Publications, Inc., 180 Varot Street, Dover, N.J. 07801
Dover Publications, Inc., 180 Varot Street, Dover, N.J. 07801

MEDIEVAL COSTUME IN ENGLAND AND FRANCE

The 13th, 14th and 15th Centuries

Mary G. Houston



PLATE I. VISIT TO A FACE-SPECIALIST : LATE THIRTEENTH
CENTURY

DOVER PUBLICATIONS, INC.
New York

Published in Canada by General Publishing Company, Ltd., 30
Lesmill Road, Don Mills, Toronto, Ontario.
Published in the United Kingdom by Constable and Company,
Ltd., 3 The Lanchesters, 162-164 Fulham Palace Road, London
W6 9ER.

Bibliographical Note

This Dover edition, first published in 1996, is an unabridged and slightly altered republication of the work first published by Adam & Charles Black, London, in 1939 as Volume III of the series "A Technical History of Costume." In the Dover edition, the original color plates appear in black and white within the text and are reproduced in color on the covers.

Library of Congress Cataloging-in-Publication Data

Houston, Mary G. (Mary Galway), b. 1871.
Medieval costume in England and France : the 13th, 14th
and 15th centuries / Mary G. Houston.

p. cm.
Originally published: London : A. & C. Black, 1939.
Includes bibliographical references.

ISBN 0-486-29060-3 (pbk.)

1. Costume—Great Britain—History. 2. Costume—
France—History. 3. Costume—History—Medieval, 500—
1500. I. Title.

GT732.H68 1996

391'.00942'0902—dc20

95-40171

CIP



INTRODUCTION

THREE centuries of dress! Surely no period in the history of costume presents more variety or interest. At a time when outlets for self-expression, even for the wealthy, were few, rich garments filled a great part of the æsthetic content of life.

Not only in the written records, but even more in the intensely careful pictorial and sculptural representations of medieval costume, have we abundant evidence of the joy men took in fine clothes, and it is important to remember, in this connection, that in the Middle Ages, Man took his clothes even more seriously than Woman and, as in the animal kingdom, was usually the more finely clad of the two sexes.

While woven materials and embroidered and jewelled decorations progressed gradually in richness and variety from 1200 till 1500 there was a comparatively rapid change and violent contrast in the cutting out and silhouette of the garments worn during the same period. What can be

Headpiece is a thirteenth-century jester (B.M., MS. 21, 926, f. 82b).

more diverse than the noble simplicity of construction and natural silhouette of the thirteenth century, compared with the slender elegance of the fourteenth, and the riot of variety and exaggeration in the fifteenth century.

To the student of medieval dress constant reference to the reigns of kings, knowledge of the regulations governing Ecclesiastical Costume and some acquaintance with such subjects as Armour, Heraldry and Decoration are a necessity. It is also important, at the beginning, to know something of the sources from which we get our information and to realise that, as is to be expected, these sources increase in numbers and accuracy, in spite of the interruption of the Black Death in the middle of the fourteenth century, as the medieval period proceeds. The influence of the Crusades, more especially at the beginning of the Middle Ages, and the great stimulus given to pattern weaving by the Moham-medan invasion of Europe were factors of the utmost significance, as was also the existence of the "Holy Roman Empire" and the consequent intercourse between Italy and Germany.

One subject of importance is, unfortunately, also a source of confusion, namely, the nomenclature of medieval garments. There is much diversity of opinion among writers on Costume with regard to these names. Some are titles on which there is very general agreement and these will be used throughout the present volume but others, the meaning of which is more or less in dispute, will be found quoted at the end of the book.

It is necessary to recollect that the medieval artists, whose paintings and sculptures give us such an accurate idea of the clothes of their day, had themselves no knowledge of the history of costume. A mid-thirteenth-century painter's

conception of the coronation of Edward the Confessor tells us most probably exactly what the coronation of Henry III. was like. Some of the illustrations of the Holy Scriptures show this lack of knowledge in a way that, but for its obvious sincerity, would be amusing to our eyes. A quaint example is that of Cain and Abel clad in the tight-fitting tunics and long pointed shoes of young men of fashion of the fourteenth century. Perhaps the most prolific source of information for students of Medieval Costume is that of the Manuscripts. They exist in such profusion and the drawings, as a rule, are executed with such painstaking exactitude that we get a very complete idea of the varied silhouettes of the centuries and the proper wear for each class and section of society.

In one department we must not expect the Manuscripts to give us much information—namely, that of the details of pattern and decoration, the scale of the drawings is so small (some exquisitely painted figures are hardly more than an inch high), that only broad effects are possible.

Most fortunately the lack of ornament on the costumes of the miniatures in the Manuscripts is supplied by that of the effigies on tombs, especially those of the fourteenth and fifteenth centuries.

The species of effigy engraved on flat stones or metal slabs, the latter, in England, often entitled "Monumental Brasses," abounds in details especially in those of ecclesiastical costume and armour.

We have also records in stained glass of much value though not so accurate or so plentiful as those in the manuscripts and tombs; and where paintings exist, especially those of the fifteenth century, there is useful information. In the great museums of Western, Central and Southern Europe there are very numerous examples of patterned

silks, some mere fragments, others which have been preserved in ecclesiastical vestments. The Victoria and Albert Museum at South Kensington has a magnificent collection of these textiles and in addition, a number of specimens of medieval ecclesiastical embroidery, these will be fully described and illustrated in this volume as far as they bear on the costumes.

While the British Museum possesses an inexhaustible treasure-house of Medieval Manuscripts, the Library of the Victoria and Albert Museum has a wonderful collection of those large volumes produced in the early nineteenth century with such care and enthusiasm by the pioneers of medieval research. The early volumes of *Vetusta Monumenta* published by the Society of Antiquaries and Stothard's *Effigies* are two of the most outstanding, but other volumes will be noted in the list of authorities at the end of the book.

The technical aspect of Medieval Costume is one which develops from garment-cutting on simple geometric lines in the thirteenth century, to the effort to fit the figure tightly which characterises the fourteenth, and lastly to the extraordinary striving after variety and novelty which is the trend of the extremely stylistic dress of the fifteenth century. Here I should like to express my thanks for the assistance so freely given me, while collecting the material for this volume, at the Manuscript Room, British Museum; the Victoria and Albert Museum; and the London Society of Antiquaries.

MARY G. HOUSTON

CONTENTS

CHAPTER	PAGE
I. THE CONSTRUCTION OF THIRTEENTH-CENTURY COSTUME	1
Early Examples — Mid-Century Types — Later Thirteenth-Century Types and Hoods.	
II. REGAL COSTUME IN THE THIRTEENTH CENTURY	12
III. AN INTRODUCTION TO ECCLESIASTICAL COSTUME AND THAT OF THE RELIGIOUS ORDERS	19
The Eucharistic Vestments in Detail—Costume of the Religious Orders.	
IV. CIVILIAN DRESS OF THE THIRTEENTH CENTURY	41
V. ARMOUR IN THIRTEENTH CENTURY AND DETAILS FROM METAL ORNAMENTS	54
Thirteenth-Century Armour.	
VI. THIRTEENTH-CENTURY ORNAMENT AS APPLIED TO TEXTILES AND EMBROIDERIES	62
Patterned Silks of the Thirteenth Century — Thirteenth-Century Embroideries.	
VII. THE STYLE AND CONSTRUCTION OF FOURTEENTH-CENTURY COSTUME	72
The Style—The Construction of Costume—Out-door Garments—Headgear and Hair-dressing.	
VIII. REGAL AND ECCLESIASTICAL COSTUME IN THE FOURTEENTH CENTURY	89
Regal Costume—Examples of Ecclesiastical Costume.	

CONTENTS

CHAPTER	PAGE
IX. CIVILIAN DRESS OF THE FOURTEENTH CENTURY Early Fourteenth Century—Middle Fourteenth Century—Working-Class Costume—Late Fourteenth Century.	95
X. ARMOUR IN THE FOURTEENTH CENTURY AND DETAILS FROM METAL ORNAMENTS	122
XI. FOURTEENTH-CENTURY ORNAMENT CHIEFLY CONSIDERED AS APPLIED TO WOVEN MATERIALS AND EMBROIDERIES Patterned Silks of the Fourteenth Century—Embroidery Patterns.	129
XII. THE STYLE AND CONSTRUCTION OF FIFTEENTH- CENTURY COSTUME The Style—The Construction of Costume.	139
XIII. REGAL, ECCLESIASTICAL AND ACADEMIC COSTUME Regal Costume — Ecclesiastical Costume — Non- Eucharistic Vestments—Academic Costume—Legal Costume.	143
XIV. CIVILIAN DRESS OF THE FIFTEENTH CENTURY Period I. Transitional—Period II. Early Fifteenth Century—Period III. Late Fifteenth Century— Period IV. Transitional to the Sixteenth Century.	159
XV. ARMOUR IN THE FIFTEENTH CENTURY AND DETAILS FROM METAL ORNAMENTS	199
XVI. FIFTEENTH-CENTURY ORNAMENT AS APPLIED TO WOVEN MATERIALS AND EMBROIDERIES	209
GLOSSARY OF MEDIEVAL TERMS FOR COSTUME	219
BIBLIOGRAPHY	221

FULL-PAGE PLATES

IN COLOUR*

I. VISIT TO A FACE-SPECIALIST: LATE THIRTEENTH CENTURY	<i>Frontispiece</i>
II. A KING AND QUEEN: MID-THIRTEENTH CENTURY	12
III. LADY AND YOUTH TALKING: EARLY FOURTEENTH CENTURY	96
IV. HERALDIC COSTUMES: LATE FOURTEENTH CENTURY	108
V. MACE-BEARER AND COURTIER: END OF THE FOURTEENTH CENTURY	112
VI. COURT COSTUMES (<i>men</i>): LATE FIFTEENTH CENTURY	120
VII. COURT COSTUMES (<i>women</i>): LATE FIFTEENTH CENTURY	144
VIII. MAN AND WOMAN IN A GARDEN: END OF THE FIFTEENTH CENTURY	190

IN BLACK AND WHITE

THREE HUNDRED AND FIFTY FIGURES IN
PEN AND INK THROUGHOUT THE TEXT

*For the Dover edition, the eight color plates are printed in black and white within the text and appear in color on the covers.



MEDIEVAL COSTUME IN ENGLAND AND FRANCE

CHAPTER I

THE CONSTRUCTION OF THIRTEENTH-CENTURY COSTUME

It will help towards a clearer understanding of the style, if the illustrations of the flat patterns are studied, previously to those illustrations showing the costumes in wear, and when these latter are described, each drawing will be referred back to the flat pattern to which it pertains.

In general the costumes of this century are cut on the simplest geometric plans and, except for a few very early examples, there is no attempt to fit the figure as was seen in the twelfth and again in the fourteenth and fifteenth centuries. Undoubtedly this extreme simplicity of construction gives the great dignity of line which is the outstanding feature of thirteenth-century costume and which is only equalled by that of the dress of ancient Greece—Ecclesiastical Costume of the century will be treated of separately. Though there is little real difference between Ecclesiastical and Civil Dress at this period as far as the *cutting out* is concerned, it will be found more convenient to refer to the two types apart from one another.

EARLY EXAMPLES

Figs. 1 to 6 are taken from types in wear about the year 1200.

Fig. 1. This is the plan of a man's tunic, reaching to the middle of the calf. The points distinguishing it as of early date are: first, the wide decorated band at neck; second, the large gusset at the armhole, extending almost to the waist. This tunic was also worn full length and in the latter form was worn by women as well as by men. The wide armhole persisted till the middle of the century.

Fig. 2. Here we have a full length woman's tunic. The points to note in this as giving the date are: first, the broad-banded decoration at neck; second, the comparatively tight fit of the upper part; third, the long hanging cuffs, a survival of the period of the exaggeratedly long sleeves of the eleventh and twelfth centuries.

Fig. 3. This is the semicircular cloak worn by both sexes, at least as early as the sixth century A.D. and continuously till the thirteenth century. In the thirteenth century it was

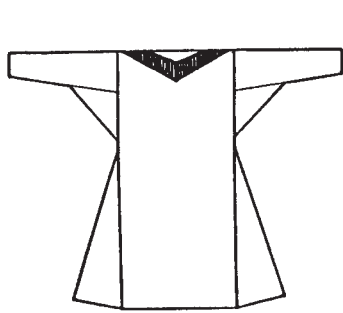

Fig. 1.

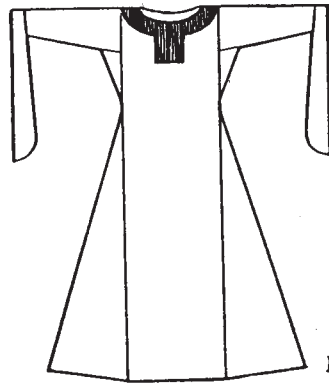

Fig. 2.

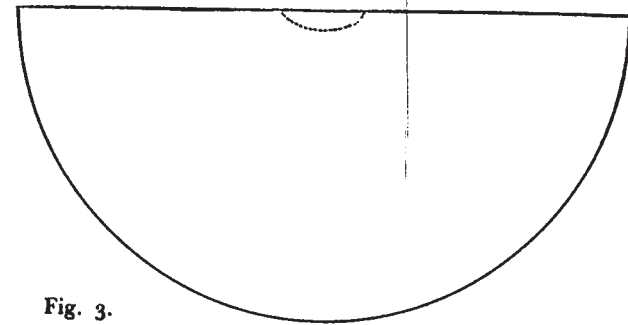

Fig. 3.

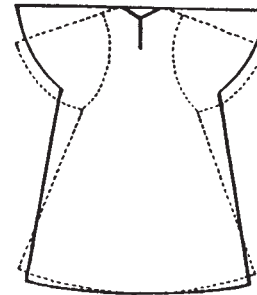

Fig. 4.

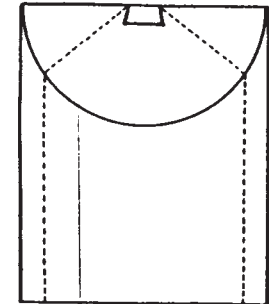
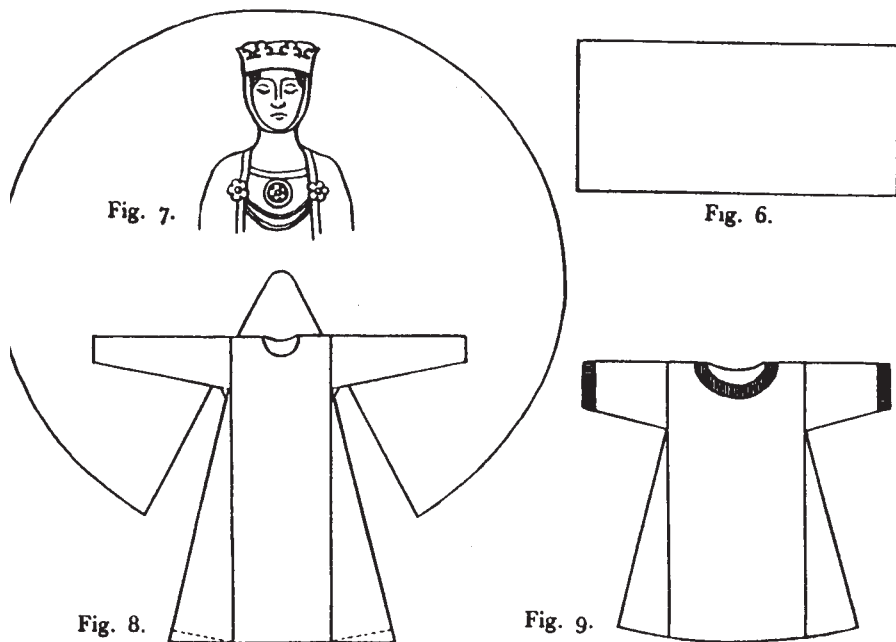

Fig. 5.

gradually superseded by a circular or almost circular garment. It was worn in various ways, either fastened with a brooch on the right shoulder (this method more commonly by men), or was wrapped round the figure in various ways, and it was occasionally worn with the opening at centre front. In this last position it was clumsy round the shoulders, and for that reason, no doubt, an improvement was made (see dotted line). This was the cutting out of a curved notch for the neck. There is a large coloured drawing, in plan, of an actual thirteenth-century garment of this type in Bock's *Die Kleinodien des Heiligen Römischen Reiches Deutscher Nation*. This is the Imperial Mantle (*Paludamentum Imperiale*) of the Emperor Otto IV. (1208-1212).

Fig. 4. This garment appears to be derived from that



wide rectangular seamless robe of very ancient origin, which we find in Egypt as long ago as 1450 B.C. and in Persia ("The Royal Robe of Persia") in the sixth and fifth centuries B.C. It continued in wear in Western Asia before and after the Christian era and in later times it is to be seen on a Romano-Byzantine Consular Ivory, fifth century A.D. (that of Stilicho and his wife Serena from the Cathedral of Monza). No longer rectangular, in the thirteenth century, but with the upper part curved inwards we find it cut as shown in the plan; we note also the lower part is considerably narrower and seamed down at each side. Viollet-le-Duc calls this garment the "esclavine" and gives an alternative method of cutting it, see dotted lines. It persists through the thirteenth century as late as 1290 (tomb in Châlons-sur-Marne Cathedral) and is seen in an early fourteenth-century

manuscript (Somme du Roi, B.M. MSS. Add. 28162, also Add. 17341, late thirteenth century). It is described in *Vetusta Monumenta*, Vol. VI., Plate XXXIX., as the "sclavine." Here the garment is worn by a figure of St. John the Evangelist, as a pilgrim (which is reproduced from the original in the "Painted Chamber" at Westminster). A hood is usually attached to the esclavine during the latter years of its wear in the thirteenth century.

Fig. 5. Shows a cape-like garment or mantle characteristic of the early years of the thirteenth century. In England it appears in Saxon times, worn both by men and women (B.M. MSS. Cott. Claudius B. IV. and Harl. 2908). Where the representations show it full and voluminous, it would be cut as shown—simply a rectangular piece of stuff folded over and the front shortened more or less and rounded off, then a hole cut for the head. Other representations suggest a cut akin to certain early "extinguisher"-shaped chasubles of the period, and the construction would be more as shown by the dotted line. This latter shape restricts to some degree the movement of the arms. Fig. 5 does not persist through the century and, on the whole, it is rare even at the commencement.

Fig. 6 is the veil, head-cloth, peplum, *couvre-chef*, of almost universal wear by women during the thirteenth century. It was not, as a rule, quite so voluminous as that worn in the twelfth. Full scale, it measures about 22 inches across, and is rather more than double this in length. Towards the end of the century, women of position discarded it for more elaborate head-dresses, but it persisted for working-class women and elderly widows and still survives among the religious orders.

The methods of dressing the hair in the thirteenth

century are easily understood when the illustrations of male costume are examined ; but in cases where the women's heads are covered, it should be said that, for the most part, the hair was parted in the centre and dressed in two plaits, which were crossed at the back and then bound round the head. At the end of the century some figures show that each plait is coiled round above the ears, giving what was called the "ram's horn" or, as we should now phrase it, "earphone" style.

That padding was used as well is easily seen when some of the head-dresses of the end of the century fashions are examined. Young girls wore their hair flowing naturally down their backs, at times confined by a fillet or chaplet. Widows wore the wimple, or gorget, round the face and the veil over their heads, in similar style to the head-coverings of the Religious Orders.

MID-CENTURY TYPES

Fig. 7. This is the almost circular cloak worn by both sexes, but more especially by women, from an early period till the close of the century. It persisted into the fourteenth and fifteenth centuries, more especially in traditional royal costume, when its simple dignity suited well a great occasion and its folds displayed the beauties of richly patterned silks. The method of fastening is shown in the small drawing of a woman's head and shoulders, superimposed (Countess Gleichen, A.D. 1260, from Jacquemin). The fastening consists of a small metal boss at either side, and this is furnished with a ring at the back, through which runs a cord or chain. This cord or chain can be drawn up and tied, if desired, so that the cloak will meet across the breast.

Fig. 8 is the characteristic tunic of the thirteenth century. It is given here full-length, but was also worn knee-length. The full-length type was common to men and women, the knee-length was worn by soldiers and men engaged in manual labour. As a rule, it was worn with a narrow girdle, which often did not show when the garment was pulled over it at the waist. When worn minus a girdle, it was inclined to trail at the sides, hence the side-pieces were sometimes sloped off, as shown, at the dotted lines. The sleeves were at times made tighter from the elbow to the wrist ; this is specially characteristic of the end of the century, where we find the practice of buttoning the sleeve tightly on the lower arm. This buttoning became very popular in the following century.

Fig. 9. This three-quarter-length tunic, with short, wide sleeves, is the ancient "dalmatic," a garment which came into fashion in ancient Rome about the third century A.D. Its name comes from Dalmatia, the country of its origin. It is by no means of frequent wear in the thirteenth century, though from the fourth century onwards, till the end of the twelfth, it was a favourite form of dress in Europe for both sexes. The dalmatic survived in the thirteenth century, chiefly in royal costume (see King John's effigy in Worcester Cathedral), and it, of course, has an important place in ecclesiastical costume, to which reference will be made in the description of that division of our subject.

LATER THIRTEENTH-CENTURY TYPES AND HOODS

Fig. 10. This garment formed a warm outdoor gown for men during the latter part of the thirteenth century. A hood was usually attached to the neck. As a rule, its

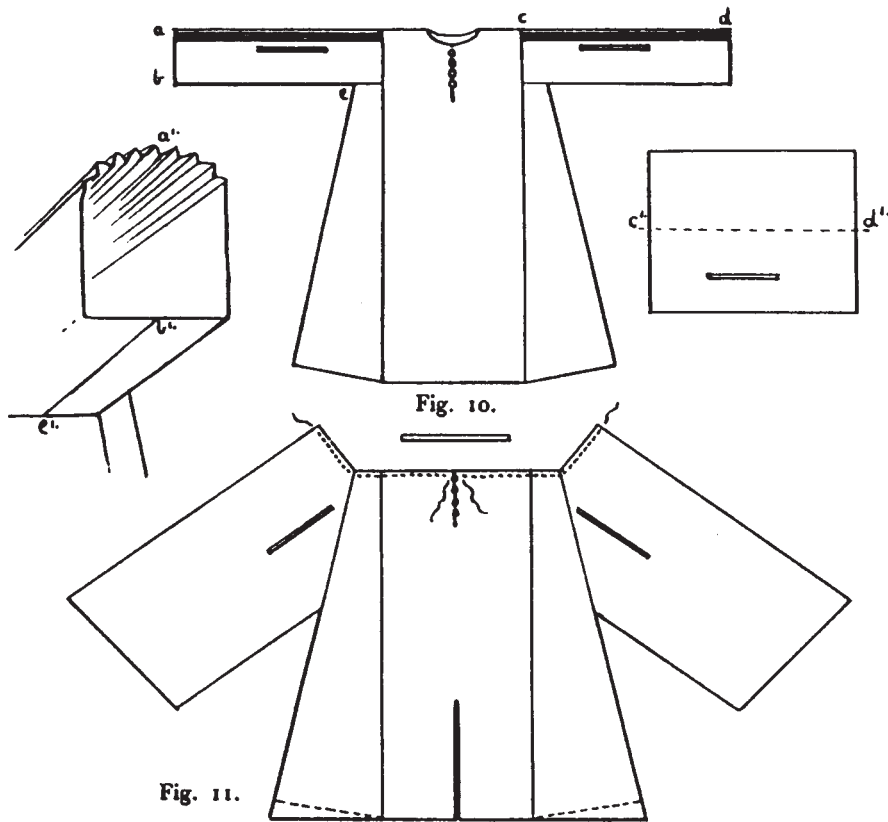

length was about seven-eighths of the figure, but it was also cut full-length (B.M. MSS. Sloane 2435). As will be seen, the sleeves were very long and wide, and no doubt in cold weather could be used as a species of muff to keep the hands warm. For convenience, however, we find slits high up on the front of the sleeves, so that the arms could be passed through and movement would not be restricted. The diagram at the right of Fig. 10 shows a pattern of the right sleeve with the gathers pressed flat, giving its correct width. On the left side of Fig. 10 the end of the left sleeve and arm-

hole are shown in perspective to a larger scale. This gown was in favour as a riding-dress. There is a reproduction in *Illustrations of Incised Slabs in the Continent of Europe*, by W. F. Greeny, of a man on horseback wearing it, with coif on his head and with gloves. He is attired for hawking and has a falcon at his wrist. Date, about 1260.

Another reproduction in the same volume shows an architect of Rheims, A.D. 1263, wearing the gown cut as at Fig. 11 which is a second type of the same garment as Fig. 10. In this, the gathers come into a small band all round the neck. A hood is attached to the neckband. The gown is full-length and split in front from hem to knee. With the gown the architect wears a beret on his head.

Fig. 12 is the sleeveless tunic usually called the "surcoat." This example is a late thirteenth-century type (B.M. MSS. Sloane 2435), but the garment shows infinite modifications throughout the thirteenth and fourteenth centuries, and persists in the dress of women as late as the end of the fifteenth, though the name is changed in these later times from "surcoat" to *super-côte-hardi*. The earliest type was that of a rectangle having a slit at top for the head and slits at the sides for the arms to pass through. This left an unsightly "poke" on the shoulders, so that these had to have their characteristic sloping seams. This simple form was the type we find worn over the thirteenth-century coat of chain mail (B.M. MSS. Roy. 12F. 13 and Cott. Nero D1, p. 45), hence the name surcoat. The figures clad in the armour of this period are said to be of the "surcoat type." Later we find

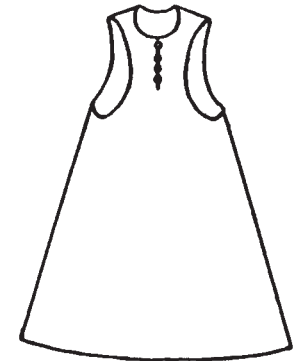

Fig. 12.

it worn by both sexes, and the armholes no longer mere slits but larger and curved away. Fig. 12 has the back piece much wider than the front, but this type was not universal. We find many types with back and front of similar shape. During the centuries this garment became more popular with women, and eventually almost disappeared from men's costume. This diagram is shown in wear on Fig. 77, p. 48, and again on Fig. 90, p. 52.

HOODS.—MAIN TYPES OF WHICH THERE WERE VARIANTS

Figs. 13 to 16 are all of ancient origin. In Etruscan and Roman times we find the *cucullus*, or hood, worn by travellers and shepherds. Fig. 13 (a side view) is a type which is worn, as a rule, detached from cloaks or other garments; it has, as it were, a cape of its own, and is seamed down the centre back and centre front (or, as in the diagram, it can be left open, and buttoned under the chin). It prevails from the beginning to the end of the thirteenth century (B.M. MSS. Roy. 1. DX. and Sloane 2435) and, in modified form, throughout the fourteenth century. The point at the back of head was sometimes much longer (B.M. MSS. Harl. 1527), and in the fourteenth century excessively so. In another variety of this hood the face opening was looser and the shoulder cape much deeper (see again B.M. MSS. Harl. 1527), also this type of hood was frequently made of sheepskin when worn by shepherds. It became more popular at the end of the century and during the

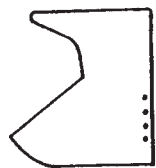

Fig. 13

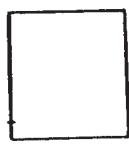

Fig. 14.

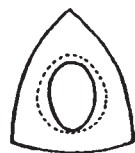

Fig. 15

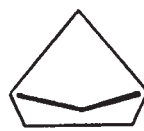

Fig. 16.

fourteenth century it was worn to the almost complete exclusion of other types which, however, survived among the monastic orders.

Fig. 14 (a side view) is the simplest form of hood. A rectangle of cloth, a little longer than twice its width, is folded in two, seamed down the back with a face-opening left in front and only a small part seamed below the chin. The bottom edge is, of course, left open and wide enough to pass easily over the head. This type of hood was sewn on to a mantle or gown; when sewn to a cloak it had, at times, no seam under the chin, so that the cloak could be worn open if desired.

Figs. 15 and 16 (both front views) are seamed at the sides. They are of the type which was attached by sewing to gowns or cloaks. In Fig. 15 the opening sometimes fitted the face closely, but other varieties show a wider face-opening, and this is suggested by the dotted line. Tiron (*Histoire et Costume des Ordres Religieux*) gives an illustration of St. Benedict wearing this type of hood, though, in this case, the front opening, instead of closing under the chin is open all the way down, so that in place of an elliptical hole, the opening takes the form of a round-topped arch. If the face-opening is tight, the point at the top remains straight up on the crown of the head in wear, but with a larger opening it can be thrown back on the shoulders and appears in that position much the same as types 14 and 16. Indeed these three types, when they are thrown back off the face and hanging down behind, are almost indistinguishable.

Fig. 16 has a shallow V-shaped slit instead of a rounded hole to admit the head and face. In Figs. 15 and 16 the part below the chin was sometimes cut longer than in the diagrams, so that it lay on the chest, shoulders, and back.

CHAPTER II

REGAL COSTUME IN THE THIRTEENTH CENTURY

It is customary to refer to styles of costume as belonging to the reign of this or that monarch—as “period Henry II.,” hence, from its importance, and from this association, we naturally turn first to Regal Costume in the thirteenth century.

We must, of course, distinguish between Coronation Robes, which, in most cases, are really of the nature of semi-ecclesiastical vestments, and the garments worn on great occasions and for ordinary wear.

Plate II. is adapted from a stained-glass window in Sainte Chapelle, Paris. In the original, the figures are seated at a table so that the garments from the hips to the ankles are hidden; in Plate II. they are drawn on thirteenth-century standing poses, the better to display their dress. These are costumes worn at a feast. The king wears a red tunic cut as in Fig. 1, but longer, and his sleeveless surcoat is similarly cut to Fig. 12, except that the skirt is much fuller and the armholes mere slits, also there are no buttons. The queen has a tunic cut as in Fig. 8; it is very long and so much pouched over the girdle that the latter does not show; the cloak is cut as in Fig. 7. The colouring is from a thirteenth-century manuscript. Shoes similar to those worn by the king are shown on page 55.

Fig. 17 is from the Effigy of King John on his tomb in Worcester Cathedral. He is represented in Coronation Robes and wears the under-tunic, the dalmatic, and the cloak, cope, or mantle, which are seen, if in modified form,



PLATE II. A KING AND QUEEN: MID-THIRTEENTH CENTURY



Fig. 20.

Fig. 20, which was also executed by W. Torel, is that of Eleanor of Castile, consort of Edward I., in regal costume. Like that of the Effigy of Henry III. the dress is of extreme dignity and simplicity, and entirely without ornament. She wears the cloak cut as in Fig. 7, under it a tunic to the feet cut on the lines of Fig. 8, but much wider in the skirt and with wider, shorter sleeves, which almost suggest the sleeves of the dalmatic. Her inner tunic is the same as that of Berengaria of Navarre.

There are, in the National Portrait Gallery of London, very beautiful electrotype reproductions of the upper half of the effigies of Henry III. and Eleanor of Castile, which enable the student to examine the details more closely than is possible from the position of the original effigies. The National Gallery publishes excellent postcard photographs

of both figures taken from the electrotypes. On pages 44 and 45 there are again illustrations of English thirteenth-century kings. They are identical in costume except for a slight difference in the shoes, and one of the figures wears gloves. The armholes of the tunics worn by both these figures are larger than those shown on Fig. 8 and approach the width of the armholes of Fig. 1.

The figure of a thirteenth-century English queen on page 44 is identical in costume with the king on the same page, except that she wears a head veil; and round her chin and face a wimple. These were both rectangular pieces of thin material (originally pure white but colours were worn later). The wimple was swathed round the chin, drawn up to the top of the head and pinned and the head veil (sometimes called *couvre-chef* or *peplum*) was thrown over it. This form of head-dress for women prevailed throughout the thirteenth century, more especially it was the wear of the older women and the women of the various Religious Orders. In the case of the Religious it has remained, if in slightly altered form, as part of the habit of many of the Orders until the present day. If the figure of the French queen in Plate II., and that of the German countess on page 4 be compared with those of the three English queens it will be seen that in the thirteenth century, Court Costume differed little in the three countries.

There is no effigy on the tomb of Edward I. in Westminster Abbey, but there is an impression of his Great Seal in the British Museum. He is here seen seated on his throne, crowned, and holding the orb and sceptre. His mantle, or cloak, is fastened on the right shoulder as in the effigy of Henry III. He wears a dalmatic similar in shape to that of King John with a long full tunic showing under it. Planché tells us, in his history of British Costume, that on opening

this king's "tomb in Westminster Abbey A.D. 1774, his corpse was discovered in a dalmatica or tunic of red silk damask and a mantle of crimson satin fastened on the shoulder with a gilt buckle or clasp four inches in length, and decorated with imitative gems and pearls. The sceptre was in his hand, and a stole was crossed over his breast of rich white tissue, studded with gilt quatrefoils in filigree work.

"The gloves, it is presumed, had perished, for the ornaments belonging to the backs of them were found lying on the hands." It will be seen that the description of this costume has much similarity with that shown on the Great Seal. Planché also gives an engraving of "a regal personage" from a MS. of the reign of Edward I. who wears a richly decorated stole, crossed on the breast. The wearing of a decorated stole, thus arranged, by the King in Coronation Vestments, dates from a period anterior to the thirteenth century. Albrecht Dürer's well-known portrait of the Emperor Charlemagne (crowned as emperor, A.D. 800), shows him thus robed and though it was executed many hundreds of years after the Emperor's death, Dürer is said to have had access to reliable sources of information not now available. This set of vestments together with Dürer's¹ imaginary portrait of Charlemagne in his traditional robes are illustrated in Bock, *Die Kleinodien des Heiligen Romischen Reiches Deutscher Nation*, the vestments are of the twelfth century, hence of later date than Charlemagne, but in similar tradition. The sixteenth-century woodblock portrait of the Emperor Maximilian I. dressed in full Coronation Robes is very similar, showing the survival of the traditional style. To go back even farther than the age of Charlemagne we have

¹ Dürer's portrait of Charlemagne and also the figures of St. Agnes and the Consul Anastasius are illustrated in Vol. II. of this series.

the figure of St. Agnes¹ in the dress of a Byzantine empress of the seventh century. She wears a wide jewelled band over her dalmatic in effect not unlike the engraving in Planché's *History of Costume*, which he describes as "a regal personage temp. Ed. I. from a thirteenth century manuscript."

Again, a similar arrangement is found on the figure of the Consul Anastasius,¹ A.D. 517. He wears a very late form of the Roman toga, folded into the shape of a band decorated with a wide border along its straight edge. The manner in which this garment is arranged round his person shows a distinct resemblance to that on the figures of St. Agnes and also to the King, as engraved by Planché, of which mention has just been made.

It is interesting to remember here (and the point will be referred to again in the chapter on Ecclesiastical Costume) that some authorities consider that the stole had its origin in the border of a garment, the garment itself having ceased to be worn and the border—now the stole—alone surviving.

We can certainly say that the influence of Byzantine Regal Costume upon that of Western Europe had by no means disappeared in the thirteenth century, indeed, in spite of alteration, we can still trace Byzantine origins in the Coronation Vestments of England in the twentieth century.

The tables on the next page of contemporary monarchs, reigning in three countries, will be found useful for reference in connection with the costumes of the thirteenth century.

¹ See note at foot of p. 16.

REIGNING MONARCHS IN ENGLAND, FRANCE AND GERMANY
THROUGHOUT THE CENTURY

<i>England.</i>	<i>France.</i>	<i>Germany.</i>
JOHN, 1199-1216. <i>m.</i> 1. Isabella of Gloucester. 2. Isabella of Angoulême.	PHILIPPE AUGUSTE, 1180-1223. <i>m.</i> 1. Isabella of Hainault. 2. Ingelburge of Denmark. 3. Agnes de Méranie.	PHILIP OF SWABIA, 1198-1208. <i>m.</i> Irene, daughter of Isaac II., Emperor of Constantinople.
HENRY III., 1216-1272. <i>m.</i> Eleanor of Provence.	LOUIS VIII. (le Lion), 1223-1226. <i>m.</i> Blanche of Castile.	OTTO IV. (the Superb), 1208-1212. <i>m.</i> 1. Beatrix of Swabia. 2. Marie of Brabant.
EDWARD I., 1272-1307. <i>m.</i> 1. Eleanor of Castile. 2. Margaret of France.	LOUIS IX., 1226-1270. <i>m.</i> Marguerite of Provence.	FREDERICK II., 1212-1250. (deposed 1245). <i>m.</i> 1. Constantia of Aragon. 2. Yolande de Brienne. 3. Isabella of England.
	PHILIPPE III. (le Hardi), 1270-1285. <i>m.</i> 1. Isabella of Arragon. 2. Marie of Brabant.	WILLIAM, COUNT OF HOLLAND, 1247-1256.
	PHILIPPE IV. (le Bel), 1285-1314. <i>m.</i> Jeanne of Champagne, Queen of Navarre.	CONRAD IV., 1250-1254. <i>m.</i> Elizabeth of Bavaria.
		<i>Interregnum.</i>
		RICHARD OF CORNWALL, 1257-1272. <i>m.</i> 1. Isabella, daughter of the Earl of Pembroke. 2. Sanchia of Provence. 3. Beatrice von Falkenstein.
		RUDOLF OF HAPSBURG, 1273-1291. <i>m.</i> Gertrude of Hohenburg.
		ADOLPHUS, COUNT OF NASSAU, 1292-1293.
		ALBERT, DUKE OF AUSTRIA, 1298-1308.

CHAPTER III

AN INTRODUCTION TO ECCLESIASTICAL COSTUME AND THAT OF THE RELIGIOUS ORDERS, TOGETHER WITH THIRTEENTH-CENTURY EXAMPLES OF THE SAME

By the commencement of the thirteenth century Ecclesiastical Costume, as such, had fully developed. Its origins, as now agreed upon by modern authorities, were in the civilian dress of the early centuries of the Christian Era. We find on the walls of the Catacombs paintings of men and women wearing what were afterwards the chasuble and dalmatic of the Church.

Those rectangular patches of decoration, which are so distinctively the ornaments of the Alb, are clearly foreshadowed on the Egypto-Roman tunics of the fourth to ninth centuries A.D. The same may also be said of the two long stripes and rectangular patches which are the characteristic ornaments of the dalmatic. Fr. Braun (*Die Liturgische Gewandung*, Braun, P., S.J.) records St. Cyprian, martyred in A.D. 258, as wearing undertunic, dalmatic, and mantle, the ordinary civil dress of the times.

Before describing each of the vestments of the Western Church in detail, it will make things clear to see them grouped together in wear. Figs. 21, 22, and 23 are those of a vested Archbishop, a Priest vested for Mass, and a Deacon similarly vested.

Fig. 21. The Archbishop is vested as follows :

1. The Mitre.
2. The Cross-Staff for an Archbishop and for a Bishop, the Crook (Crosier or Pastoral Staff).
3. The Amice with its apparel.
4. The Chasuble.
5. The Pallium.
6. The Orphrey of the Chasuble.
7. The Maniple.
8. The Dalmatic.
9. The Tunicle.
10. Apparels of Alb.
11. Gloves.
12. Ends of Stole (showing under the Chasuble, and worn by an Archbishop or Bishop without crossing).
13. The Alb.
14. The Sandals.
15. The Buskins.

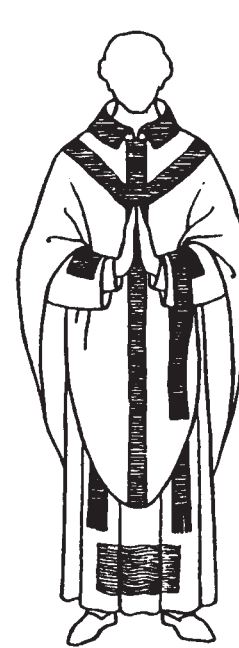

Fig. 22.



Fig. 21.



Fig. 23.

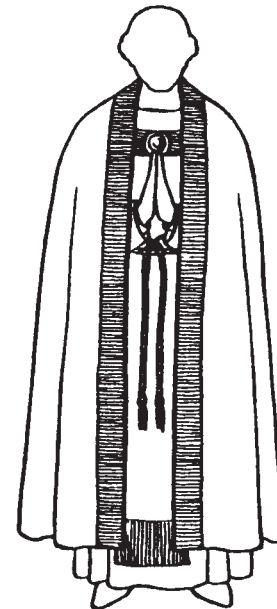

Fig. 25.



Fig. 24.

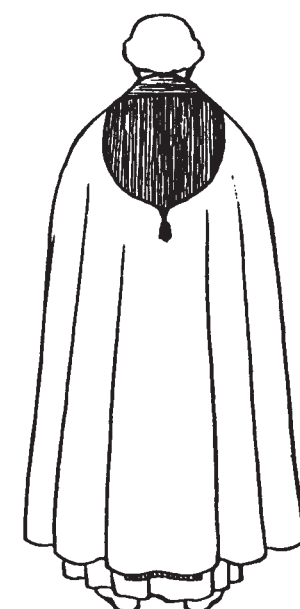

Fig. 26.

Fig. 22 is a diagram of a Priest vested for Mass. His costume includes :

1. The Amice with its apparel.
2. The Orphrey or decoration of his Chasuble.
3. The Chasuble.
4. The Sleeves of his Alb.
5. Apparels at wrists of Alb.
6. The Maniple.
7. Ends of the Stole which he wears crossed in front and fastened by girdle.
8. The Alb.
9. The Apparel in front of Alb.

Fig. 23 is a Deacon similarly vested. He wears :

1. The Amice with its apparel.
2. The Dalmatic or the Tunic.
3. The Orphreys of the Dalmatic.
4. The Sleeves of the Alb.
5. Apparels at wrists of Alb.
6. The Maniple.
7. Apparel of the Dalmatic.
8. The Alb.
9. Apparel of the Alb.

The Stole is worn by Deacons over the left shoulder.

Diagrams Figs. 21, 22 and 23 can be used for reference when examining the illustrations of ecclesiastical costume for the three centuries. Those examples taken from the manuscripts have not the same accuracy as we find on the large effigies of brass and stone. For example, on page 42 the stole of the Archbishop Leofric has been omitted, whereas in an earlier representation of an archbishop (Stigand) from the Bayeux tapestry the stole is clearly indicated.

Vestments are of two types, Eucharistic and Non-Eucharistic.

THE EUCHARISTIC VESTMENTS IN DETAIL, TOGETHER WITH A DESCRIPTION OF THEIR CONSTRUCTION OR CUT

1. *The Alb.*—For flat pattern (which pattern is a measured drawing from the Victoria and Albert Museum, No. 8710 of 1863, and is thus labelled—“Albe, white linen, with apparels of crimson silk, Sicilian fourteenth century”), 94 in. wide by 65 in. high over all, see Fig. 27. This vestment can be worn by bishops, priests, deacons, sub-deacons, acolytes and choristers

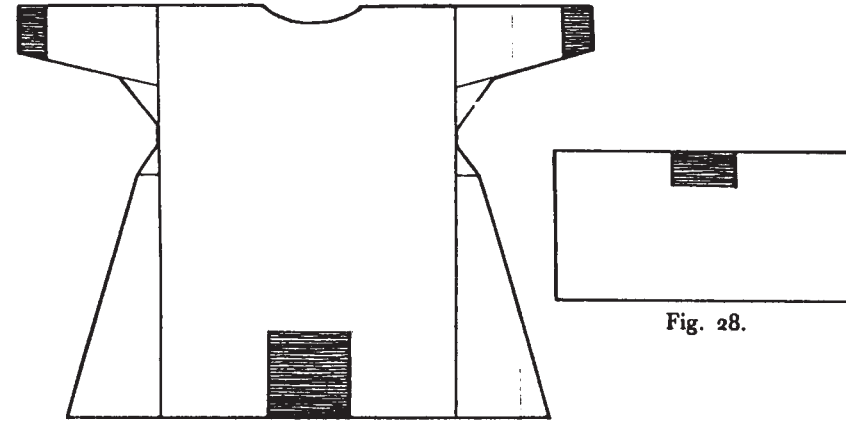

Fig. 27.

Fig. 28.

and closely resembles the long tunic worn by the laity up till the end of the thirteenth century. As its name indicates, its prevailing colour was white. It should be made of fine linen and if it be ornamented it should have “apparels,” which are worked in silk and gold. The most ancient kind of apparels take the form of borders at the hem and wrists but later they consisted of quadrangular pieces measuring, according to Pugin, from 20 in. by 9 in. to 9 in. by 6 in. for the bottom, and from 6 in. by 4 in. to 3 in. by 3 in. for the wrists.

2. *The Amice.*—A white linen napkin or veil worn by all clergy above the minor orders. It is the first of the sacred vestments to be put on, first on the head, then adjusted round the neck. It has strings about 74 in. long attached to the two corners of the apparelled side. The strings are passed under the arms from the front, brought round the back and tied on the breast. The Eucharistic amice must be distinguished from the almuce or grey amice worn as a monastic or academical garment, which will be illustrated in a later chapter. The apparel was sewn on to the top edge

of the amice and formed the collar which is invariably represented on the effigies of ecclesiastics. The linen part of the amice protects the rich silk of the chasuble or dalmatic from touching the skin. Its measurements varied. That of St. Thomas of Canterbury is square with the apparel running along the whole of one side; the example given (see Fig. 28) is much longer and has a very short apparel, its number in the Victoria and Albert Museum is 8307 of 1863 and its label reads as follows: "Amice, linen, with crimson silk apparel on which are sewn ornaments in silver and silver gilt. German, fifteenth century, 4 ft. 2 in. by 2 ft."

3. *The Chasuble*.—The original form of this vestment was perfectly round with a hole in the centre for the head to pass through. It was large enough to cover the whole body and its name is said to be derived from the Latin word *casula*—a little house. Pope Honorius, who died in A.D. 638, is represented in a mosaic in the Church of St. Agnese at Rome, vested in a chasuble which touches the ground all round covering his entire figure (over it he wears the pallium). During the centuries the chasuble became shorter at the sides and hung down in front and behind in long points but it was frequently soft and voluminous in its folds (for flat patterns see page 25). Eventually it was clipped, altered, and at the same time stiffened, so that we get what has been called the "fiddle-back shape," shown on page 145. The Y-shaped orphreys which decorate so many of the older chasubles were derived from the pallium, they imitate its appearance, and they occur both in front and at the back.

The various plans of cutting out the chasuble exhibit considerable diversity. While numerous representations show that the cut of the garment is undoubtedly based on the Roman traveller's circular cloak, to which reference has

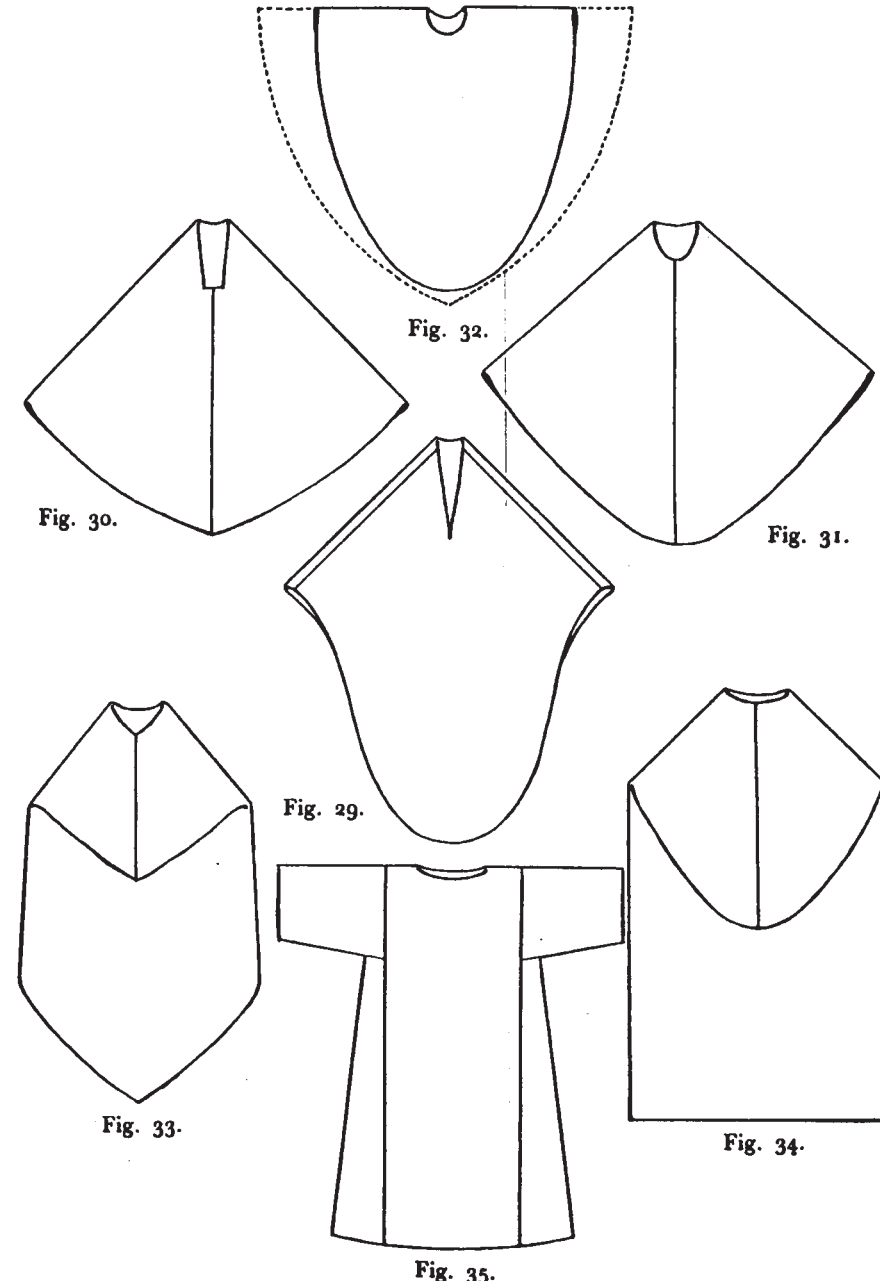

been made, other drawings and sculptures indicate a semi-circular construction even as far back as the eleventh century. R. A. Macalister, in his book *Ecclesiastical Vestments*, describes how a piece of material in the form and about the size of a cope (i.e. a semicircle of 10 ft. diameter) had a semicircular notch (to give room for the head to pass through when it has been made into the chasuble by seaming) cut out of the middle of its straight edge, the parts of the straight edge on either side of the notch were then joined in a seam and so an "extinguisher"-shaped chasuble was formed. If this had not been clipped at each side to a considerable degree, there would have been great difficulty in using the arms when wearing it. The well-known "Chasuble of St. Thomas of Canterbury," now at Sens, and the so-called "Chasuble of St. Dominic," are both of the "extinguisher" shape (though not exaggeratedly so) as described by Macalister.

There are illustrations of both of them in Viollet-le-Duc, who gives the length of the former as 3 ft. 10 in. For their plans see Figs. 30 and 31. Fig. 29 is a measured drawing of a thirteenth-century chasuble in the Victoria and Albert Museum (No. 8359 of 1863) and the silk from which it is made is described on page 65. The seams here are on each shoulder, perhaps because the striped silk looks much better when so seamed. (This chasuble measures 59 in. in length and 48 in. in width.) Fig. 33 is a plan, in reconstruction, of the rather crude drawing of the chasuble worn by Archbishop Stigand in the Bayeux Tapestry, whereas the thirteenth-century drawing of Archbishop (Leofric), Fig. 47 on page 38, indicates a chasuble cut out of a circular piece of stuff and then slightly clipped or shortened at either side. The plan of Fig. 32 would be in its wider form (see dotted lines) nearer the thirteenth-century Leofric, though the

pictured garment is shorter in front and longer behind. This plan, Fig. 32, is from a reconstruction by Pugin.

Fig. 34 is a reconstruction of the chasuble worn by the bishop in Fig. 52*a*, p. 42. Fig. 52*b* may be taken as an enlargement of the head of the crosier carried by the bishop in Fig. 52*a*. Victoria and Albert Museum, early thirteenth century (English work), No. M88 of 1920. This drawing was copied from a very early thirteenth-century manuscript in the British Museum (Roy. 1 DX.). It shows a form of chasuble which has a rectangular back and which was not unknown as a secular garment in eleventh, twelfth and early thirteenth century. There is a fine reproduction in Stothard's *Effigies* of a very softly-draped thirteenth-century chasuble apparently almost circular, which is another example of the type clearly developed from the ancient Roman *casula*. This is draped upon the statue of Hugh de Northwold (Bishop of Ely from 1229 to 1254). Finally, we can undoubtedly conclude that thirteenth-century chasubles varied considerably in shape as has been already remarked.

4. *The Dalmatic*.—This vestment takes its name from Dalmatia, it having been in general wear among the inhabitants of that country from an early period. It became the fashion among both lay men and women in ancient Rome after the fourth century. It is shorter than the alb and has shorter, wider sleeves, as can be seen in the illustrations, also it is slit at the sides from the bottom upwards for some distance. It has already been shown in wear on Fig. 23. Fig. 35 is a measured drawing of a thirteenth-century dalmatic in the Victoria and Albert Museum. The silk from which it is made is shown on page 65. Fig. 36 is a drawing copied from a thirteenth-century manuscript in the British Museum (No. Harl. 29-30, f. 14*b*). It represents the Angel of

the Annunciation (in the original the figure has wings but these have been omitted). The Angel is wearing a dalmatic (Fig. 37) decorated with plain borders, not with rectangular apparels as in later specimens. The drawing in the manuscript is so minute that there is no space for decoration on these borders, but Fig. 38 is from another thirteenth-century manuscript and is given to show the sort of pattern which might have been embroidered in gold on the borders of a dalmatic of this type. The textile pattern above (Fig. 39) is sketched from the original in the Victoria and Albert Museum (it will be more fully described in the chapter on thirteenth-century textiles). If the thirteenth-century artist had been depicting—say on a monumental brass—a larger figure, we may imagine he would have used a pattern in style similar to this one. The illustration of the dalmatic from the Victoria and Albert Museum (Fig. 35) does not show the side-slit but in this case it extends right up to the arm. In wear this type would, of course, be tied, buttoned or laced sufficiently to keep it in place on the figure.

5. *The Tunicle* is distinguishable from the dalmatic by being slightly shorter and not so ample. An exception to this rule is shown in the diagrammatic figure of the archbishop (Fig. 21) where his dalmatic is made shorter to show that he is wearing the tunicle underneath.

The tunicle was the vestment for the sub-deacon at Mass, but for the sake of symmetry at the altar the distinction between the dress of the deacon and sub-deacon eventually disappeared and we read in medieval inventories of a chasuble with two dalmatics or two tunicles to match. An inventory from Lincoln Cathedral reads, "Item, a chasuble with two tunacles of blue tissew."

6. *The Maniple*.—One of the sacred vestments assumed

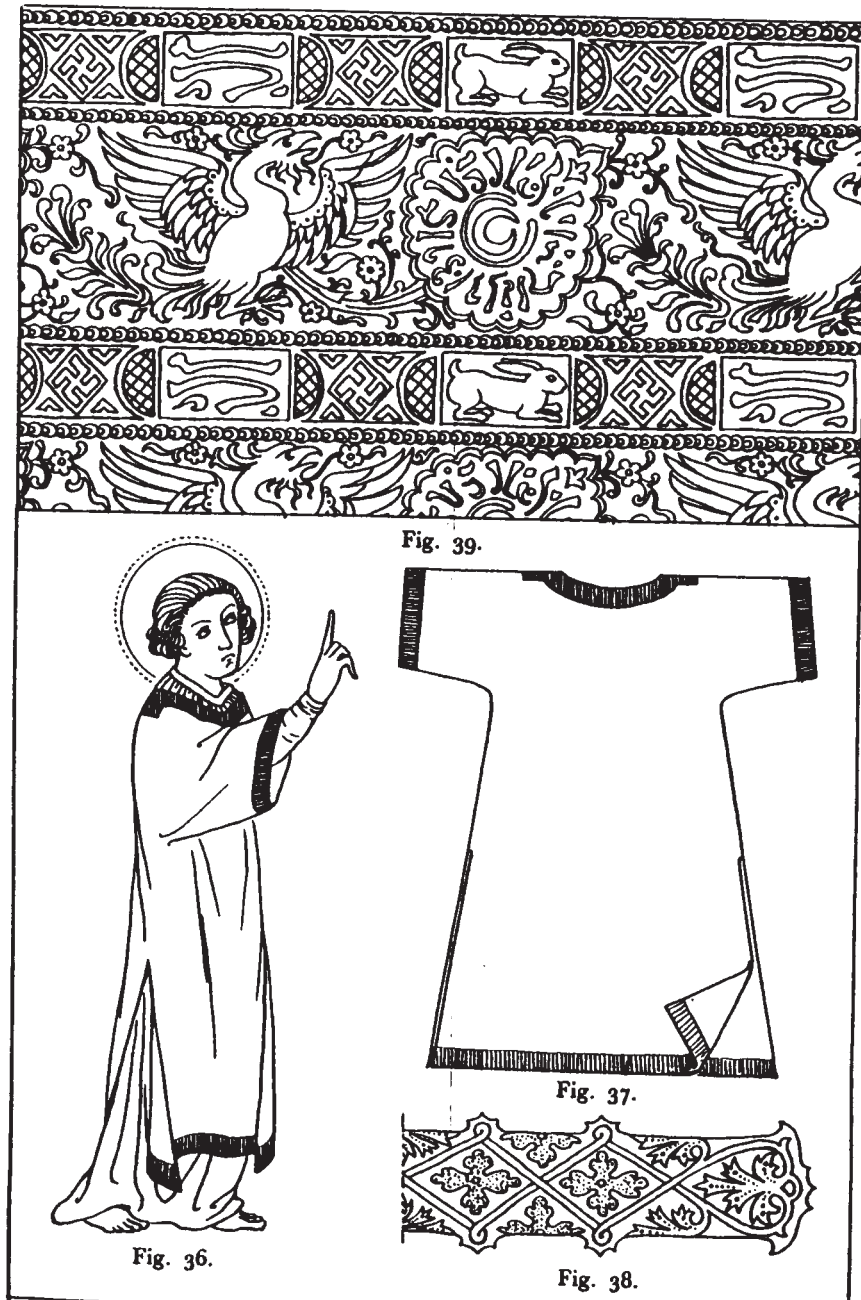

Fig. 36.

Fig. 39.

Fig. 37.

Fig. 38.

while serving at the altar. It was worn by bishops, priests, and deacons, and by the thirteenth century it had been conceded to sub-deacons. It was originally a narrow band of linen used as a handkerchief, for wiping the forehead, face, etc., but during the Middle Ages it had become a stiff, richly-decorated band with fringed ends and was merely ornamental. It was, at first, held in the left hand but afterwards looped over the left wrist, see Figs. 21 to 24. Pugin gives its length as 3 ft. 4 in.

7. *The Stole as a Eucharistic Vestment.* The stole has been already described as a part of the royal Coronation Vestments, but in the service of the Church it is worn according to rule—hanging straight down from the shoulder for bishops, crossed over at the waist under the girdle for priests and over the left shoulder by deacons. It is about three yards long (Pugin). For illustration of the stole in wear when not covered by other vestments see Fig. 24, p. 21.

8. *The Cope.*—This is not one of the Eucharistic Vestments; it belongs to the Processional Vestments but as these latter were not so fully developed in the thirteenth century as in the fourteenth and fifteenth it will now be described separately and the remainder of the Processional Vestments in a later chapter (see page 149). The cope (Latin—*cappa*). The word was identical with cape and was used until comparatively modern times as an outdoor dress by the clergy or laity. The word *pluviale* (rain-cloak) used by the Roman Church indicates its original use. By the thirteenth century it had taken on its present semi-circular shape. The hood which was once attached to it had disappeared except in simulation. Its plain surface had been enriched by decoration so that it became the most splendid of all the vestments. Figs. 25 and 26 show the cope in wear, back and front view. Fig. 40 is

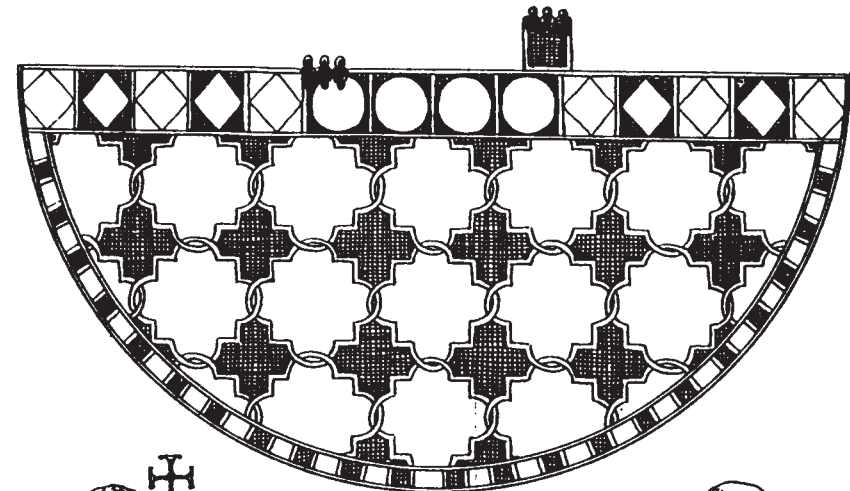

Fig. 40.



Fig. 42.

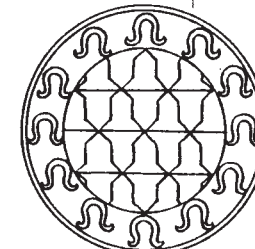

Fig. 40a.



Fig. 41.

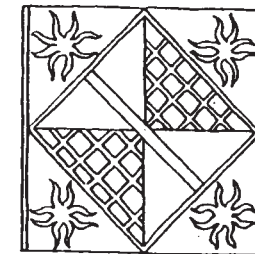

Fig. 40b

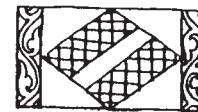

Fig. 40c.

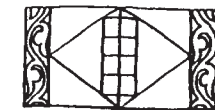

Fig. 40d

a diagram of the celebrated Syon Cope now in the Victoria and Albert Museum, the decorations of this vestment will be described in a later chapter, see page 71. Figs. 40a to 40d are enlargements showing portions of the decorations of the orphrey and border of the Syon Cope. Fig. 42 is that of an acolyte wearing the alb, undecorated, and what seems to be an amice with no apparel. It is from the same manuscript as Figs. 36 and 41. Fig. 41 is from the same manuscript as Fig. 36 (i.e. British Museum, Harl. 29-30). Though of the thirteenth century it shows, not the stiff, richly-decorated vestment of the Syon specimen, but the garment more nearly in its original form of a protective cloak with hood attached, but in this case there would most probably be a curved notch cut out at the neck to improve the set at the shoulders. This cope sometimes receives the name of choir-cope. Figs. 25 and 26 show the characteristic ornaments of the cope, namely, the orphrey, hood and morse, the drawing sufficiently explains their position but the hood varied in shape through the centuries. In the thirteenth century the hood became a small triangular piece of stuff, merely simulating its origin as a hood; in the fourteenth and fifteenth centuries it became larger again, and took on the shape of a shield, hence sometimes called *clypeus* (Latin=shield). It was often detachable.

Though not one of the Eucharistic Vestments the cope is sometimes worn by certain ranks of the clergy when assisting at Mass, also at the Mass of the Pre-sanctified on Good Friday.

The following vestments pertain only to bishops and archbishops.

The Pallium.—This belongs to archbishops exclusively and only worn when granted by the Pope. It is a narrow

band of white lamb's wool and the medieval shape is that of a circle going round the shoulders with a pendent band back and front, see Fig. 21. In Fig. 47 we see a variety in which the shoulder part is of a V shape. It is exactly the same before and behind, and the only ornaments upon it are small crosses. It is said that the original pallium was a long straight band and that a loop was made in the middle, the loop was placed over the shoulders and the ends pinned so as to hang down back and front as at present. The effect was untidy and difficult to keep in place hence the present form of pallium is cut to shape. Dr. Rock thinks that the pallium is a survival of the Roman toga which in one of its latest forms had a broad band of ornament along its straight edge and was so folded that the garment itself was concealed underneath the band (as already referred to on page 16). It was then thrown round the figure after the manner described on page 17 in the chapter on Coronation Vestments; this would give to the pallium the same origin as the stole.

The Mitre.—Pugin defines it as a covering for the head worn on solemn occasions by bishops, cardinals and the abbots of some monasteries and by special privilege by the canons of certain churches. It was originally a raised cap with a band round the edge and not divided before the tenth century. The horns or points were first at each side, not front and back as we find it in the thirteenth century and afterwards. There are two representations of St. Thomas of Canterbury which give us these stages in the development of the mitre which are illustrated in the diagrams Figs. 43 and 44 and p. 34. Fig. 43 is from a manuscript miniature of St. Thomas of Canterbury (Trinity College, Cambridge, B.V. 4). Fig. 44 is from a twelfth-century seal

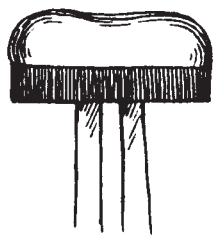

Fig. 43.



Fig. 45.

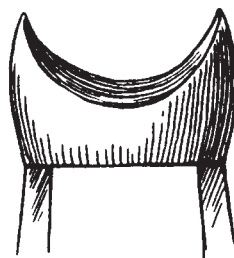

Fig. 44.



Fig. 46.

of the same saint. Fig. 45, which shows the characteristic thirteenth-century form with low points back and front is from Strutt's *Regal and Ecclesiastical Antiquities*. Further modifications and developments in the shape of the mitre took place in the fourteenth and fifteenth centuries as will be seen in the illustrations to those centuries. There are, in the fully-developed type of mitre, three sets or grades according to the richness of the decorations. 1. The *Mitre Pretiosa*, which is richly decorated and jewelled for use on great occasions. 2. The *Mitre Aurifrigiata* which, as its name implies, was ornamented with gold orphreys. 3. The *Mitre Simplex*, which was of plain white linen. It can be judged from the various illustrations throughout the book to which of these classes each mitre belongs. There is a thirteenth-century sculptured representation of an archbishop on the porch of the north transept of Rheims Cathedral which gives the mitre in profile, see Fig. 46. The two pendent bands of embroidered material which hang down at the back of the mitre are called the *Infulæ*. Their original use was probably to tie under the chin and keep the mitre firmly on the head; they had become mere ornaments before the thirteenth century.

The Episcopal Gloves.—These had become part of the habit of a bishop vested for Mass even before the thirteenth century. They were often embroidered and sometimes richly jewelled.

The Buskins.—These are really stockings, originally of linen, later of silk or velvet. When embroidered the pattern was generally of an all-over design, Fig. 120, p. 70. Embroidery from the tomb of Bishop Walter de Cantelupe is from the centre front of a buskin. See also Fig. 56, p. 42. They ended at the knee where they were tied with a ribbon.

The Sandals.—These were low shoes, generally embroidered and sometimes tied with a ribbon lacing. Anyone who has the opportunity should consult that great work by Monsignor Bock, *Die Kleinodien des Heiligen Romischen Reiches Deutscher Nation*, 1864. In this magnificent folio the author illustrates with all possible splendour of real gold and colour, that set of Royal Vestments of the twelfth century and other garments, which give us much information as to the details and construction of medieval dress even though they are of earlier date than the thirteenth century. In this volume there are fine illustrations also of the Imperial buskins, sandals and gloves which are of the same type as those worn by high ecclesiastical dignitaries. There is a copy of the above work in the library of the Victoria and Albert Museum, London.

The Bishop's Crosier or Crook.—This is the bishop's Pastoral Staff. The word crosier meant originally the bearer of a crook and is in no way connected with cross, though the words have been confused. (See *Concise Oxford Dictionary*, 1923.) The cross sometimes carried by an archbishop, as in Figs. 21 and 47, is his *Cross-Staff*, which he has in addition to his crosier. The cross-staff should properly be borne before him by a cross-bearer. The crosiers of the Middle Ages were often lavishly decorated. Precious metals, enamels and jewels enriched them. Examples will be given in a later chapter. The thirteenth-century crosier was foliated with the characteristic scroll-work of this century, an example of which is given, Fig. 106, on page 55, also Fig. 52*b*, a drawing of a thirteenth-century crosier from the Victoria and Albert Museum on page 43. The Bishop's consecration ring was worn on the right hand and usually of pure gold set with a sapphire.

The Liturgical Colours.—These were not so uniform nor

so constant in medieval times as at present. In England, for example, the "Sarum Colours" had no authority outside the diocese of Sarum. Bath and Wells, Lichfield and Westminster Abbey all had their separate customs in these matters. The ancient sequence of colours in the diocese of Bath and Wells had the following use: blue for Advent, white for Christmas and the octave of the Epiphany; the colour for St. John's Day was blue or white; for the Innocents, red; the Circumcision, red or white. From the octave of the Epiphany to Septuagesima red was worn. From Septuagesima to Passion Sunday probably blue was used. Red was worn from Passion Sunday and Advent, except on Low Sunday and the octave of the Ascension, when white was worn. As elsewhere, the colour for Apostles and Martyrs was red; Virgins, those of them who were not Martyrs, white; while the colour for Confessors was blue or green. Funerals were to be in black.

COSTUME OF THE RELIGIOUS ORDERS

As with ecclesiastical costume, the origin of that of the Religious Orders was in civil dress. The choice of garments was, of course, made to suit a life of poverty and detachment from worldly pleasures, hence its extreme simplicity in style and materials and its sober colouring. The great diversity of the Orders and their number prevent a full description of them in any work on costume save those entirely devoted to this branch of the subject. A list of authors thus specialising will be found at the end of the book.

Figs. 48 and 49 are from a thirteenth-century manuscript, No. 28,784 Bff. 513. Fig. 48 is a picture of St. Francis in



Fig. 48.



Fig. 47.



Fig. 49.

the costume of the order which he founded. The gown and hood were grey at first but later (fifteenth century) changed to brown. The knotted girdle is white. It need hardly be said that in the thirteenth century this habit was cut on the same simple geometric lines so widely prevailing at the time. Fig. 49 is a thirteenth-century representation of St. Dominic. He also wears the habit of his order. Here the gown is white, as also the "scapular." This scapular is of very frequent wear among the religious orders; it is simply a rectangular piece of stuff hanging down from the shoulders before and behind. It has shoulder seams and a hole for the head to pass through, otherwise it is quite detached and hangs free. The Dominican cloak is black and the hood

black with a white hood inside. This black cloak and hood correspond with the description of that processional vestment called the "Canon's cope" or "choir cope," namely, "a simple choir robe of black, permanently sewn at the neck, but open from the breast downwards and with a hood attached." The Benedictine Order which, of course, existed before those of St. Francis and Dominic, had for its regular habit an under-tunic of full length and over this a wide full-length gown with loose hanging sleeves, and a hood was attached. There is on this gown neither girdle nor scapular. The colour is black throughout. Tiron, when writing of the earlier years of the order (its "Rule" is mentioned as early as A.D. 528), gives an illustration of what he calls "an ancient Benedictine," and in this the under-tunic is white and the hood black, as also the outer tunic, which latter is about the length of the average dalmatic and joined to the hood. A Benedictine habit is shown at Fig. 265, p. 151.

The women's dress in the Religious Orders is on very similar lines to that of the men, the chief difference being that where the man has a hood the woman has, as a rule, a head-veil and wimple or gorget. Figs. 50 and 51 on page 40 are from the Abbé Tiron's History. Fig. 50 represents a Dominican nun of the Order (founded in 1206 at Prouelle, near Toulouse). The head-veil is black, with a white veil lining it; the wimple, gown and scapular are white. Fig. 51 is a sister of the Third Order of Servites, founded in the thirteenth century at Florence. Her veil and wimple are white and all the remainder of her habit is black. "This order bore the name 'Mantellate' from the special mantle they wore in the exercise of their charitable functions" (Tiron).

CIVILIAN DRESS OF THE THIRTEENTH CENTURY

BEFORE describing the costumes as worn by the leisured classes and manual workers, it may be remarked that in the former class there are changes in style perceptible throughout the century, whereas in the latter there are no very great differences between 1200 and 1300.

Figs. 52-54 are from a very early thirteenth-century manuscript in the British Museum, Roy. 1 DX. (Fig. 52 has been mentioned previously, as it comes under the heading of ecclesiastical costume, and the mitre, chasuble, dalmatic, alb and amice which are here shown have already been fully explained). Fig. 53 shows the very wide armhole and heavily embroidered neck-trimming which date it as early in the century, see plan, Fig. 1, which explains the construction. Fig. 54 again shows its date chiefly by the pendant hanging from the end of the sleeves and the neck trimming, see again Figs. 2 and 3 for the cutting out.

Figs. 55 and 56 are examples of the change from the type of scrollwork ornament common about the year 1200 (see Fig. 55) to the fully developed style of the thirteenth century shown in Fig. 56. Both these patterns are from the British Museum. Fig. 55 is from an enamelled casket which in itself is of interest to the student of costume as it is decorated with dancing figures similarly garbed to Figs. 53 and 54. The Museum sells an excellent postcard photograph of this casket, No. XIX. 7. The border, Fig. 56, is from a



Fig. 50.

Fig. 51.

A DOMINICAN NUN AND A SISTER OF THE THIRD
ORDER OF SERVITES.



Fig. 53.



Fig. 52a.



Fig. 54.



Fig. 55.



Fig. 56.



Fig. 60.

fragment of an embroidered vestment found in the tomb of Bishop Walter de Cantelupe (Worcester Cathedral) who died in A.D. 1265. The fragment here shown is preserved in the British Museum.

Fig. 57. There is little difference between this costume and that of Fig. 58, they are both from the same manuscript (Roy. 1 DX.), this figure, with Fig. 58, representing two of the Magi. Fig. 58 wears the semi-circular cloak, and the sclavine (see Fig. 4 for construction), and underneath a tunic similar to that worn by Fig. 57.

Figs. 59 and 60 (representing the Blessed Virgin and Elizabeth) are wearing that outer robe, the pattern of which is given in Fig. 5. We have this garment illustrated in the manuscripts in England from Anglo-Saxon times, and it is seen on both men and women; on men, see British Museum manuscript Cott. MS. Claudius B IV., and upon a woman, Harl. MS. 2908. This garment disappears quite early in the thirteenth century, but its relation to a form of the chasuble should be noted. Compare Figs. 59 and 60 with

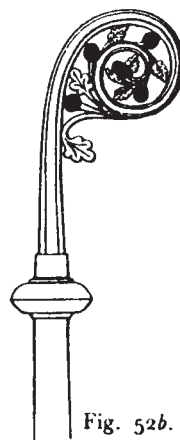

Fig. 52b.

This crozier which is one of the simpler types in the Museum's collection of Medieval Croziers is called "The Hyde Abbey Crozier" and the label reads as follows—"Copper gilt, hammered and chased, decorated with conventional vine foliage and fruit. Found about 1788 with a stone coffin in the grave of an abbot at Hyde Abbey, Winchester. Height 12.35 inches." Museum No. 88 of 1920. The height of the head of the crozier, here given, is roughly about one fifth of what the entire staff must have measured before the lower part disappeared.



Fig. 61.

Fig. 62.

Fig. 63.

Figs. 64a, 64b, 64c.

Fig. 52a. One last point to note about these two costumes is that there is no wimple under the chin.

To pass on to the fully developed style of the thirteenth century, we can see its features well displayed in the two groups of figures from that justly celebrated manuscript, "The Lives of the Offas," British Museum MS. Cott. Nero D₁, illustrated by Matthew Paris, or a contemporary monk of St. Albans.

In the first group, Figs. 61-65, we see a king and queen, an architect or master builder, a nurse and three children. The cutting of these extremely simple costumes has already been explained. The cloaks are semi-circular and all the tunics based on Fig. 8, page 4. In the second group, Figs. 66-70, we see the investiture of a knight, whose outer tunic, with its ornamental neckband, is a survival from the

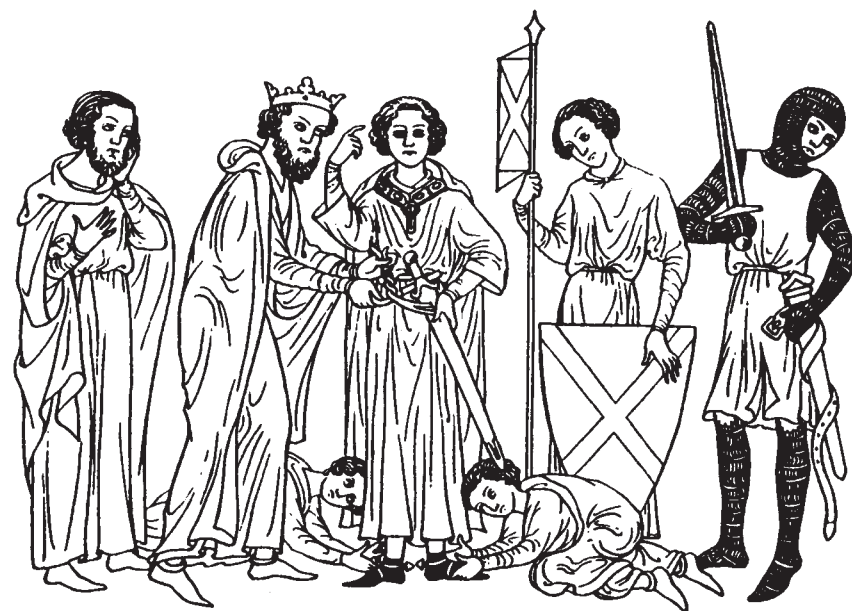

Fig. 66.

Fig. 67.

Fig. 68.

Fig. 69.

Fig. 70.

beginning of the century and may be said to be a species of dalmatic. The knight in armour wears a surcoat over his coat of mail—the latter will be described in a later chapter. An esquire stands holding shield and banner. Fig. 71 on p. 46 is from a thirteenth-century sculpture in Amiens Cathedral. This elderly man wears a mantle and hood similar to that worn by the Religious Orders, he has also the close cap or coif, which was a favoured form of headgear for men in the thirteenth century. He is seated at a fire toasting a fish on a fork. The construction of his outer mantle and inner tunic is on the usual simple geometric lines.

Towards the end of the century a certain amount of elaboration begins. Perhaps it is most marked in the headgear of both sexes, but there is a distinct tightening of the tunic in many cases, and the introduction of more elaborate

gowns or outdoor dresses for the men, who did not favour the wearing of the circular cloak as much as did the women at this period.

Plate I. (*frontispiece*) is from a British Museum (Franco-Flemish) manuscript of the late thirteenth century (Sloane MS. 2435, which is called "The Health Book"). The subject of the drawing is entitled "Visit to a Face Specialist." The details showing its period will be found in the headgear of both figures. The lady introduces a new note by wearing a hairnet, and the linen cap and bound-up chin of the "face specialist" are also a novelty. We find the same arrangement on a woman, see Fig. 73 on opposite page.

In the group of men and women shown in Figs. 72-76 we have all the characteristics of the end of the century. The group is taken from a British Museum manuscript (Add. 17341). It will be noticed that the two men, Figs. 72 and 76, are wearing a coif and beret respectively. Fig. 76 is a characteristic costume for doctors and architects. The gown this figure wears has been given in flat pattern in Fig. 10, p. 8. "The Health Book," of which mention has been previously made, has several illustrations of physicians exactly as Fig. 76. This garment is also shown in wear in "Lives of the Offas" (Matthew Paris), hence not unknown in mid-thirteenth century.



Fig. 71.

The outstanding features denoting change of style in the three women are, Fig. 73, her padded and netted hair which is also the mode for Fig. 74, but the head of Fig. 73 has an attenuated remains of the wimple or gorget



Fig. 72. Fig. 73. Fig. 74. Fig. 75. Fig. 76.

bound round her chin and a species of linen coronet or band as well. Children, as shown here and at 64*a*, *b* and *c*, page 45, are clothed as their elders, but more simply, and Fig. 75 might stand for the costume of the child's nurse; she has knotted up her head-veil most ingeniously so that it does double duty for veil and wimple. The two costumes, Figs. 77 and 79, are, like Plate II., from "The Health Book" (Sloane MS. 2435), and represent the same person in spring and winter dress. For similar dress, compare with Fig. 90, p. 52. Fig. 77 wears the surcoat cut as described in Fig. 12, p. 9.

The colour scheme of this figure in the original manuscript is as follows: hood, red, with white border; surcoat, purple, with white borders at armholes and neck; undertunic, dark blue, shoes and stockings white. He has put on



Fig. 77.

Fig. 78.

Fig. 79.

his hood with the crown of his head in the part meant for a face opening, while the part meant to be on his shoulders hangs out at the back. Fig. 79 is wearing his hood in the proper manner, and his mantle is cut as in Fig. 10, p. 8.

Fig. 79 in the original manuscript is coloured as follows : mantle and hood, brownish-purple with white buttons and borders ; shoes and stockings, pinkish-white.

Fig. 78, which is from a British Museum manuscript,

Add. 17341, is an example of the survival of the *sclavine* in wear late in the thirteenth century. It should be compared with the early example already given at Fig. 58, p. 42. The hat is of simple "sugar loaf" shape, with the brim turned up. The colouring of this figure in the original manuscripts is as follows : hat, red, lined white ; mantle (*sclavine*) and hood, purple, lined red ; undertunic, red ; shoes and stockings, black. For cutting out, see Fig. 4.

These three colourings, Figs. 77, 78 and 79, have been given in full, as they are typical examples of late thirteenth-century colour schemes and seem to be to some extent representative of actual garments. This is by no means always the case, as some of the finest representations of costume such as those at Figs. 61-70 are merely in outline or very lightly tinted. The coloured plates are as far as possible closely based on originals, and where there is any variation (as Plate II.) it is so stated.

Fig. 80 is taken from a British Museum manuscript, "probably written in Lincoln diocese not earlier than 1280," No. Add. 38116 ff. 8b 13. The figure represents Eve spinning, from the Old Testament. The points which show this costume as late thirteenth century are : (1) the tightening of the tunic, this being generally found at the beginning of the century, not in the middle, then again at the end ; (2) the head-dress ; this is very typical of the end of the thirteenth and beginning of the fourteenth century. It is very similar to Fig. 73, but the padding under the hair-net is not so marked, also the coronet of linen is splayed out at the top—less of a band.

The colouring of this figure is as follows : coronet and wimple or gorget, as it may now be named, white ; hair-net, green ; full-length tunic, pale dull purple.

THE DRESS OF MANUAL LABOURERS IN THE THIRTEENTH CENTURY

Figs. 81 to 92 are, with one exception (Fig. 90), all similar in dress, their actions in the drawings for the most part indicate their occupations.

Figs. 81 to 84 are from a British Museum manuscript (a psalter), Roy. 1 DX., and are of the early part of the century, yet their dress differs little from that of the workers of nearer 1300. The cutting out is on the same lines as those already explained. To get a general view of early thirteenth-century types, they should be compared with the

other contemporary costumes from this splendid manuscript, namely, Figs. 52, 53, 54, 57, 58, 59, 60.

Fig. 85a is from a manuscript entitled "The Trinity College Apocalypse," dated about 1230. This man is clad in hunting costume and while his other garments are the same as those already given, he wears in addition a pair of white knee-length drawers which are tied in at the bottom. An explanation of their cut is given in Fig. 85b. Another contemporary manuscript (Harl. 4751), not here given, shows three men hunting in similar dress, two



Fig. 80.



Fig. 81.

Fig. 82.

Fig. 83.

Fig. 84.



Fig. 85a

Fig. 86.

Fig. 87.

Fig. 88.

are wearing the small coif or close-fitting cap, one has drawers, like Fig. 85a, but the two others have loincloths similar to those illustrated in Fig. 95. It is, however, some-



Fig. 89.

Fig. 90.

Fig. 91.

Fig. 92.

times difficult to distinguish from the small drawings in the manuscripts whether the undergarment worn is a loincloth or a pair of very short drawers.

Figs. 86 and 87—shepherds—are taken from a late thirteenth-century British Museum manuscript (Harl. 1527). Their hoods are loose enough to accommodate a hat underneath if necessary, and the capes attached to the hoods are long enough to give some protection from the weather. The colouring of Fig. 87 is rather interesting, and is as follows: hat, blue; hood and cape, fawn colour; tunic, dull rose colour; stockings, blue; boots, black.

Fig. 88 is from "The Lives of the Offas" (MS. Cott. Nero D1). The knickers or drawers here are not gathered in at the knee but are as in the plan, Fig. 85*b*. Fig. 90, from Amiens Cathedral, is a bird-charmer. Figs. 89-95 are, with one exception (Fig. 93), from thirteenth-century sculptures in Amiens Cathedral. They are of interest in the idea they give of the different garments worn at the different seasons of the year, Fig. 95 being in loincloth alone.



Fig. 93.

Fig. 94.

Fig. 95.

Fig. 93 is a shepherd from Sainte Chapelle (thirteenth-century stained glass). This man is in a long tunic, his semi-circular cloak is thrown off his shoulders and his hood is attached to it.

The leg coverings of the majority of these wearers of short tunics are clearly displayed. When long, i.e. reaching up as far as the top of the thigh—they were called hose or chausses and were not joined at the top but put on separately and kept up by being tied with strings to a belt round the waist. They were made of leather or cloth. For description of their probable cut, see Chapter XIV. page 181. Shoes were sometimes worn over these hose or stockings, see various examples illustrated. They were, as a rule, only the height of the instep or ankle, but the illustrations show also examples of short hose or buskins worn over the longer hose or chausses, these reaching up as far as the calf of the leg. Fig. 94 is wearing the long breeches (*braies* or *bracchæ*) of ancient Gaul. These would be cut on the same plan as the short drawers, the plan of which is given at Fig. 85*b*.

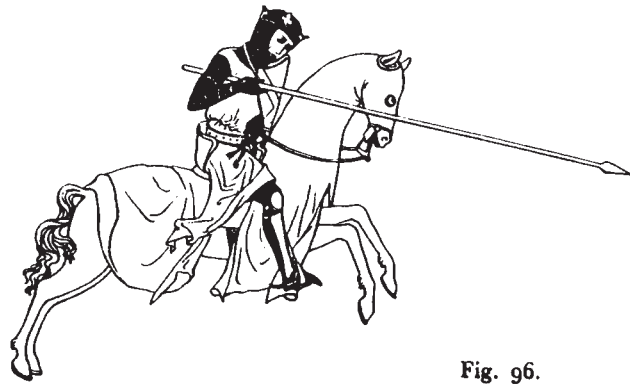

Fig. 96.

CHAPTER V

ARMOUR IN THE THIRTEENTH CENTURY AND
DETAILS FROM METAL ORNAMENTS

In the churches both of England and the Continent there are fortunately still preserved a great number of tombs with effigies and many of the larger of these, more especially those of regal personages and ecclesiastics, give us, in representation, the wrought and jewelled metal-work which enables us to form a definite idea of such ornaments as crowns, mitres, brooches, girdles and rings. These are all set forth in the effigies with the greatest care for detail. If it were not for this fact, we should find it difficult to picture these precious ornaments, as there are not very many actual pieces surviving. Fig. 97 is the crown of Berengaria of Navarre (see also Fig. 18, p. 13). Fig. 99 is her brooch. The brooch, as can be seen, is of that very ancient type which has been handed down to us from prehistoric times in Europe—namely, a circle of metal with a pin which has a metal eyelet so designed that it will move loosely on the ring. The ornament decorating the ring gives the brooch its thirteenth-century character.

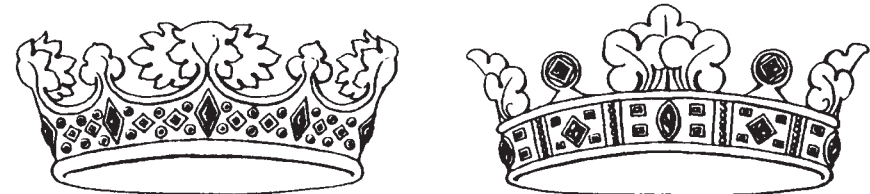

Fig. 97.

Fig. 98.

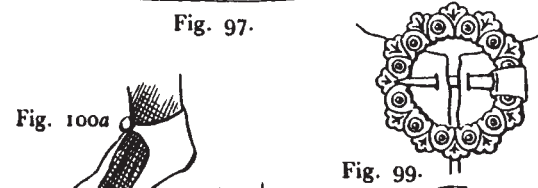

Fig. 100a

Fig. 99.



Fig. 101.

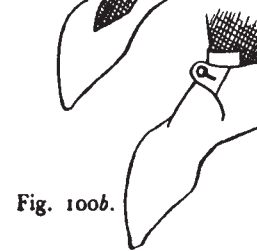

Fig. 100b.

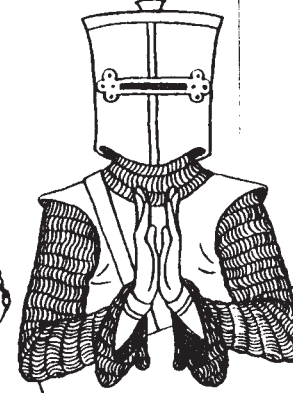

Fig. 102.

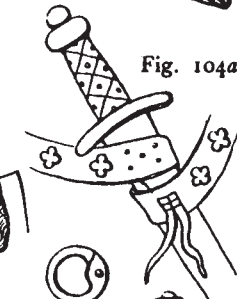

Fig. 104a.

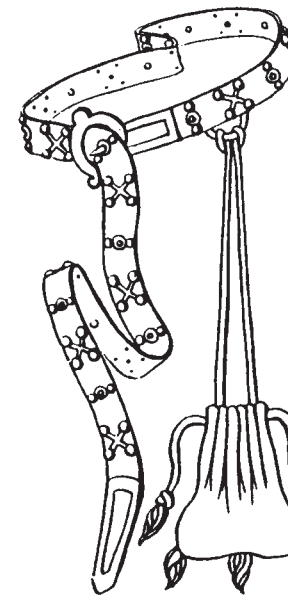

Fig. 103.

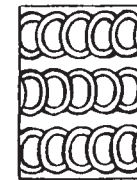

Fig. 105a.



Fig. 105b.



Fig. 105c.



Fig. 107.

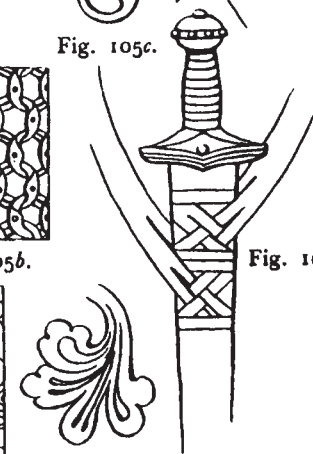

Fig. 104b.



Fig. 106.

Fig. 98 is the crown of a figure from the Cathedral of Notre Dame de Paris (thirteenth-century sculpture). Fig. 100*a* is from the feet of the effigy of a man at Châlons-sur-Marne Cathedral and dates about 1290. Fig. 100*b* is from a tomb, also of a man, at Ghent, and dates about 1271.¹

Fig. 103 is a girdle, probably of leather, decorated with metal bosses and with an alms bag attached. It is, like the crown at Fig. 97, from the effigy of Berengaria of Navarre.

Fig. 106 is a piece of the characteristic foliated scroll work, in relief, which is found in wrought stone and metal and is the most characteristic ornament of the century. This example is from "The Stone Church," Kent.

Fig. 107 is an enlargement of the embroidered pattern on the shoes of the Westminster Abbey effigy of King Henry III. ; compare with Fig. 19.

THIRTEENTH-CENTURY ARMOUR

While it is essential to study the specialised literature on the subject (see Appendix), if anything like a complete knowledge is desired, it will be of interest to examine some examples of such representations of armour as are found in the manuscripts and effigies of the thirteenth century.

This period is characterised by the general disappearance of that padded and quilted armour of fabric or leather so frequent in the eleventh and twelfth centuries and the substitution of the coat of mail which, however, often retains the padded armour beneath it. By the end of the thirteenth century chain mail covered the entire figure and small metal plates began to be used at vulnerable points, foreshadowing the plate armour of the next two centuries. The larger scale of the details at Figs. 101, 102, 104*a* and *b* and

¹ For Fig. 102 see references on pp. 57-58.

105*a* and *b* serve to explain more clearly than is possible in the smaller illustrations following, several important points.

Fig. 101 shows the characteristic prick spur of the thirteenth century, which was afterwards replaced by the rowel spur. Fig. 102 is from an effigy in the Brussels Museum dating from about 1200 to 1230. It shows the flat-topped "barrel" helm, which replaced the conical helmet with nose-guard of the previous century. This figure also shows how the hand coverings could be adjusted, cf. Fig. 112.

Fig. 104*a* is a sword-belt from the museum at Evreux, dated 1290. It shows one of the characteristic methods of attaching the scabbard to the belt, by twisting the belt round the scabbard and lacing it with thongs. Fig. 104*b* shows another method of attachment by leather thongs ; it is from a tomb at Poitou.

Figs. 105*a* and *b* are enlargements of the detail in the drawings of the various thirteenth-century coats of mail illustrated. Fig. 105*a* is often called "banded mail" by writers, and is considered by various authorities to have consisted of rings of iron sewn on to a foundation of leather or stout fabric, such as several thicknesses of linen. Figs. 70 and 96 show this type of mail in wear.

Fig. 105*a* is an enlargement of the wrought iron rings which compose the true "chain mail." It will be seen that where the rings have been riveted, they are flattened out, and widened to take the rivet. Fig. 105*c* is an enlargement of a single ring. Much discussion has been caused by the varied methods adopted by medieval artists in the representation of chain armour, and in the early nineteenth century Sir Samuel Meyrick, in his pioneer work on the subject dated 1824 (see Appendix), made various classifications of the different arrangement of rings in the mail.

Nowadays experts (see Laking) are of opinion that the immense time it would have taken to draw every little ring correctly, inclined the thirteenth-century artist to use a sort of shorthand or convention to express his idea in line or relief, so that too much importance must not be attached to the differences in the drawings of mail which will be found in the manuscripts and effigies.

Figs. 108, 109 and 110, are from a British Museum manuscript, Roy. 12 F. 13, a thirteenth-century "Bestiarum."

Fig. 108 is not entirely clothed in mail. His face and hands are unprotected and his leg guards are not of mail but of some padded fabric or leather. In the manuscript he is in the act of spearing a wild beast.

Figs. 109 and 110, in combat with one another, are fully armed except for their hands and are wearing the same "barrel" helm already illustrated at Fig. 102, p. 55.

Fig. 111 is from that early thirteenth-century British Museum manuscript, Roy. 1 DX., from which several drawings have been reproduced on page 42. This is a figure of the giant Goliath from the Old Testament. He is not completely armed, having no armour protecting the legs. The narrow knotted sword-belt contrasts with the wider and more elaborate examples of the later years of the century.

To turn back to Fig. 70, p. 45; here we have a mid-thirteenth-century knight from "The Lives of the Offas" (MS. Cott. Nero D1). Besides his hauberk or coat of mail which fully covers hands and neck he wears a small skull cap (*coif de Mailles*—Planché), his leg armour (*chausses*) has the extra protection of knee-cops of steel or leather (*cuir bouilli*) strapped on over the mail. His plain surcoat reaches to the knee. It should be said that the scabbard at his side is not



Fig. 108.

Fig. 109.

Fig. 110.

Fig. 111.

that of the original drawing which was unfortunately not very clearly indicated. Instead a scabbard has been taken from Add. MS. 28784 B. f. 2 which, it must be confessed, is of slightly later date than that of the figure of the knight himself; the scabbard manuscript being catalogued as "later thirteenth century."

The manuscript—"Lives of the Offas"—has a great number of illustrations of battle scenes showing weapons and horse trappings in addition to armoured knights, in short giving a very full picture of military life in the first half of the thirteenth century. (For example, see head-piece of this chapter, Fig. 96.)

Towards the end of the century we find a number of effigies in stone and brass which give us the detail necessarily lacking in the spirited but tiny drawings of the manuscripts.

Fig. 112 is from the brass of Sir Roger de Trumpington

in Trumpington Church near Cambridge, dating about 1289. Behind his head is a great conical tilting helm which, in wear, rested on his shoulders. The helm is attached by a chain to a cord (the latter not showing) which confines his surcoat at the waist. He wears a coat or shirt of mail (hauberk), a mail coif on his head, stockings of mail (chausses) and gloves, knee-cops of steel or leather (*cuir bouilli*), prick-spurs, and at his shoulders are "ailettes" of fringed leather. These last were two small pieces of armour used to give extra protection to the shoulders and lessen the force of a glancing blow. They are drawn in this effigy as if they were parallel to the full face to satisfy the story-telling passion of the thirteenth-century artist. In reality they should be at right angles to the full face and parallel to the profile and so would look like mere lines from the front. The heraldic shield with its devices of trumpets and crosses is repeated in miniature on the scabbard and the same devices again on the ailettes. His coat of arms, *azure, crusuly and two trumpets in pale or*, appears no less than seven times—first upon the shield on his left arm, then on the ailettes, and four times upon the scabbard of his sword. On the ailettes and scabbard it is "differenced" by a label of five points.

Though the monumental brasses and stone effigies of the thirteenth century are not so numerous as those of the fourteenth and fifteenth the study of the specialised books dealing with these two subjects is valuable for information on armour. For list of such books see Appendix.

Fig. 113 is a silk pattern of the thirteenth century which will be described in the next chapter; it is contemporaneous with the figure of the knight and we can imagine that he or his wife might have possessed a cloak or gown of this very splendid material for wear on great occasions.



CHAPTER VI

THIRTEENTH-CENTURY ORNAMENT AS
APPLIED TO TEXTILES AND EMBROIDERIES

PATTERNED SILKS OF THE THIRTEENTH CENTURY

THESE fabrics are fortunately preserved in great numbers in the more important national museums in Western, Central and Southern Europe. The Victoria and Albert Museum, London, has a truly magnificent collection. The interest and variety of the patterns have inspired a considerable literature and two English authorities in whom the silks have roused an enthusiastic admiration may be quoted—namely—William Morris and A. F. Kendrick, the latter late Keeper of the Textile Department in the above Museum.

The designs did not reach their finest and fullest development till the last half of the thirteenth century and the beginning of the fourteenth. At the present date, in 1939, there is a tendency among experts to move the dating forward, so that silks formerly labelled thirteenth century may now be labelled fourteenth.

On broad general lines, however, it may be said that, at the commencement of the thirteenth century the style of the designs was stiffer and the details of a single pattern somewhat heterogeneous in character—some from Byzantine sources, others from Arabic and again perhaps Chinese. Later a thoroughly homogeneous style was evolved, yet it was characterised by an effortless ingenuity and variety unequalled in the history of pattern design.

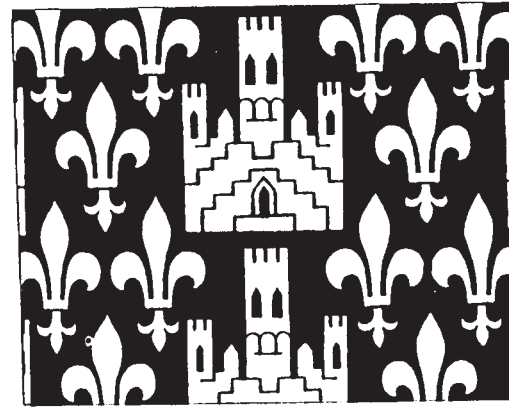

Fig. 114.



Fig. 115.



Fig. 116.



Fig. 117.

the Palermo silks were the admiration of the cathedrals and courts of Western Christendom.

It would be impossible, save at great length, to enumerate all the typical groups of patterns but we may first consider a very simple group of geometric or heraldic character and without oriental imagery, all from the Victoria and Albert Museum.

To this group belong Figs. 114 to 117. Fig. 114 is labelled "No. 8592 of 1863, woven silk tissue, with the badges of Charles of Anjou, King of Sicily in 1266, second half of the thirteenth century." The pattern is gold-coloured silk on a

In spite of their variety the designs run in numbers of well-defined types which admit of classification. In Europe the place of origin from whence the earliest medieval silks were exported was Sicily, when silk-weaving schools began to be famous about the middle of the twelfth century where the Mohamadan invasion had already placed a number of skilled oriental weavers and designers. Under the Norman kings of Sicily the industry was fostered and

red ground. The actual size of the castle in this design is about $2\frac{1}{2}$ inches high.

Fig. 115 is labelled "No. 8252 of 1863, Italian thirteenth-century silk and gilt thread." The ground is dark blue and the fleur-de-lis in actual size is about 2 inches high.

Fig. 116 is labelled "No. 831 of 1899, Italian thirteenth century." The ground of this is dark blue and the crescents, which measure about 3 inches across, are gold. This pattern is the same as one which is painted on the robes of Eleanor, Queen of Henry II. of England, on her effigy in the Abbey of Fontevraud, Normandy.

Fig. 117 is labelled "No. 49 of 1892," red and gold tissue of same date.

Turning back to Fig. 39, p. 29, we have a textile of a very different character from the four simple designs already described. It belongs to a type of pattern which was plotted out in two horizontal bands, a narrow and a wide alternately. Their actual size was, for the wide band about 6 or 7 inches and for the narrow about $2\frac{1}{2}$ or 3 inches. The wide band in Fig. 39 has "a splendid phoenix with outspread wings and florid tail." The tail betrays "a tendency to become transformed into flame. The Chinese feeling is here recognised." (A. F. Kendrick.) A conventional leaf divides the phoenixes and its surface is ornamented with Arabic letters. The narrow bands have also Arabic letters, geometric panels and panels with a hare alternating. The pattern is woven in gold. The backgrounds of the wide bands are blue and peach-colour alternately, and those of the narrow bands are crimson. There is a textile of this type of design in the Victoria and Albert Museum labelled "765 of 1893." A. F. Kendrick gives its origin as probably Palermo, thirteenth century; other authorities consider it may have



Fig. 118.

been imported from Mesopotamia as late as the fourteenth century.

On page 61, Fig. 113 shows still another type which has a thoroughly oriental character and with certain modifications was a favourite with weavers for three or four centuries. In this type the foliations on the limbs of the animals was used by the Mohammedan designers to prevent realism (forbidden by their religion) in their patterns. The variations of this type are perhaps more numerous than that of any other design. There is an example in the Victoria and Albert Museum, "No. 591 of 1884, woven at Mecca, thirteenth century." An inventory of St. Paul's Cathedral, London, shows that this pattern was used for a cope in the year 1295 and it survives till the early sixteenth century.

Fig. 118 is the design used for the dalmatic, the flat pattern of which is shown at Fig. 35, p. 25. Victoria and Albert Museum label is "No. 1369 of 1864, weaving—Sicilian twelfth or thirteenth century." The wide bands are about 6 inches wide and the narrow 3 inches. The ground is much faded but probably dark blue and the ornament on the wide band is coloured white; that on the narrow is woven with gold thread; the shaded portions, such as the eyes and collars of the dogs, are deep red. This design is another example of the banded type already mentioned, but here the style has become more homogeneous, though we can still trace the Arabic letters and the "flowery fowls" from China.

Fig. 119 is from a textile in Danzig Museum; the actual size may be calculated from the size of the deer which is, from feet to ear-tips, about 6 inches. This design is typical of the greater freedom of arrangement and gaiety of treatment which occurred at the end of the thirteenth and



Fig. 119.

beginning of the fourteenth century. To quote William Morris when he writes of this type of design he says, "the wild fancy and luxurious intricacy of the East with the straightforward story-telling and clear definite drawing of mediaeval Europe are the very crown of design as applied to weaving"; and again, "the richness of imagination in these stuffs is amazing"; and again, "beasts and birds are frequent, arranged in opposition on either side of the holy tree or holy fire, often simply passing their lives in the scenes of nature and generally admirably drawn as to their characteristics, though, of course, generalised. . . . Then we have castles, fountains, islands, ships, ship sails, and other such inanimate objects. Finally the weaver uses the human form . . . seldom complete. Half-women lean down from palm trees, emerge from shell-like forms among the woods with nets in their hands, spread their floating hair over the whole pattern, water their hounds at woodland fountains." A. F. Kendrick says, "Another design hardly less imaginative . . . beneath a date palm with drooping branches and hanging clusters of fruit are two female figures each stretching out one hand to pluck the fruit and grasping with the other the back of a hound below. From among the branches of another palm tree two female figures bend down to seize two lions by the mane." The design which William Morris describes as "ladies watering their hounds at woodland fountains" is given in the fourteenth-century division of this book on page 132, Fig. 138.

THIRTEENTH-CENTURY EMBROIDERIES

While ecclesiastical vestments were richly decorated with needlework, there does not seem to have been any very

extensive use of embroidery upon civil costume in this century. The indications of its presence upon the richer secular costumes of the age are not numerous and, when we do find it, the decorations are almost always confined to the borders of garments. These borders, however, are most infrequent when we compare them with those of the previous centuries where the richly-jewelled and embroidered edgings were a dominant feature in Byzantine dress.

There is, at the same time, no possible doubt that embroidery as an art had come to a very high pitch of perfection even in the twelfth century, and in the thirteenth, England especially became so celebrated for its needlework that the famous *opus Anglicanum* was sought for in the cathedrals and courts of Europe, but its use was chiefly ecclesiastical. One type of design used for thirteenth-century embroidery consisted of the characteristic scrollwork or foliated spirals of the period with their peculiarly fascinating character, which may perhaps be best described by saying that they have all the vigour of youth, such as we find in plants unfolding in the spring. In the round or in relief these designs have certain attractive qualities from the play of light and shade on their carved or embossed surfaces (compare the crosier at Fig. 52B and the carving Fig. 106), but in embroidery, where they are, of course, in the flat, they are treated with extraordinary lightness, delicacy and grace. Fig. 120 (a Jesse Tree), in spite of the quaint and primitive treatment of the human figure, shows the delightful contrast of the coiling spirals and the straight, vigorous detail shooting off the main stem. It is a reconstruction from the fragments of a buskin from the tomb of Bishop Walter de Cantelupe (who died in 1265 or 1266); the tomb is in Worcester Cathedral and the fragments are now in the



Fig. 120.

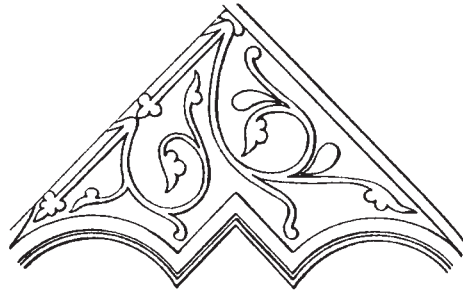

Fig. 121.

British Museum. The Victoria and Albert Museum has another smaller fragment of the same, No. 1380 of 1901. The colouring is much faded but the ground appears to have been red silk and the embroidery in gold thread and coloured silks.

Fig. 121 is taken from another example of the scrolled and figured type of embroidery and is to be found in a chasuble in the Victoria and Albert Museum, No. 8359 of 1864, second half of the thirteenth century. It is probably a few years later in date than that of Bishop Walter de Cantelupe's buskin. This is on a blue satin ground with embroidery of gold thread and coloured silks. The broad orphrey down the centre has figure subjects in quatrefoil compartments, with delicate scroll-work filling in the interspaces (one half of one of these interspaces is shown at Fig. 121), but the rest of the vestment (unfortunately much mutilated) has a design of the scroll-work running freely over the surface, still keeping its exquisitely light and delicate character and enclosing in its spirals lions and griffins alternately. Had this embroidery been intended for a secular purpose these foliated scrolls and heraldic animals would have made an admirable design.

The most celebrated example of English thirteenth-century embroidery is the "Syon" cope. It represents

another style of design differing completely from the two examples of the type already described; it is very fully discussed and illustrated by A. G. I. Christie in her great work on English Medieval Embroideries (see Appendix). Mrs. Christie considers that the cope was originally designed as a chasuble and illustrates this point with drawings showing where the mutilations occurred. In the Syon cope the ground of linen is entirely covered by the stitchery, so that it does not show at all. The design consists of interlacing barbed quatrefoils (which are shown at Fig. 40, p. 31, where the plan of the cope is given). The quatrefoils are filled with exquisitely worked groups of figures of sacred character and the interspaces have six-winged angels standing on wheels. The orphrey and outer border are of a different type of embroidery and have been added at a later time. Details from these latter parts of the cope are shown at Figs. 40*a*, *b*, *c* and *d*. They represent a third style of thirteenth-century embroidery design differing entirely from the scroll-work type and that in which groups of figures are set in geometric shapes. This third type is heraldic and though it was much more highly developed in the fourteenth century, it is also to be noted in the thirteenth.

CHAPTER VII

THE STYLE AND CONSTRUCTION OF
FOURTEENTH-CENTURY COSTUME

THE STYLE

To get a clear view of fourteenth-century styles, we may divide the period into Early, Middle and Late. These three broad divisions take account only of general characteristics and pass over such facts as the survival of older types amongst the working classes, especially amongst countrymen, also the conservation of the styles of the previous centuries in regal and ecclesiastical costumes.

While the opening years of the period under review show little change, save a slight tightening of the gowns and tunics of the previous century, we soon become aware of an increasingly sheath-like effect in the men's tunics and in the similar but longer garments of the women.

By 1360 fashion has left the thirteenth century behind it and the unmistakable style of the fourteenth century is strongly evident. Tight, sheath-like garments for both sexes, belts worn low on the hips, sleeves becoming fanciful, shoes very long and pointed are the mode.

At the century's close the waist-line rises again, women's skirts become fuller, sleeves for both sexes are still more fanciful and often bag-shaped or bell-shaped.

Outdoor garments do not, until towards 1400, show nearly so much alteration as do the indoor costumes. The semi-circular cloak of the thirteenth century tends to disappear, but the full circle or three-quarter circle remains

popular as a cloak pattern. The loose-fitting sclaveine (see p. 97, Fig. 165) is still in vogue, though not of frequent use. At the close of the century the "houppelande" became a popular out-of-doors dress for men, and the long full gowns worn indoors by women at the same period were similar in style. Examples illustrating this point are given on pp. 113 and 119, Fig. 209 and Figs. 217, 220, 221. When we examine the loose long-sleeved gown of the thirteenth century (see Fig. 79, p. 48) and compare it with the houppelande, it seems not impossible to trace a connection, if a neckband and belt be added to the former, together with a lengthening of the skirt. This thirteenth-century gown, however, survives in its characteristic if slightly modified form during the fourteenth century, but it cannot be said to have been popular.

THE CONSTRUCTION OF COSTUME

When we endeavour to reconstruct the garments of this period we may first take as a foundation or basis of our plan the T-shaped thirteenth-century tunic (see Fig. 8, p. 4) and then consider the problem of how it was tightened to make a tunic of the year 1330, for example.

It is very clear that at that remote period we should have had no background or tradition of tight-fitting styles to guide us (we may dismiss that cutting-in at the sides which gave a tight but wrinkled body to some of the gowns and tunics of the twelfth and very early thirteenth century, which were tight but did not really fit). We must therefore start from the loose T-shaped tunic and notice how the skirt part is made to flare or widen by studying the drawing of an actual fourteenth-century garment (the alb) on Fig. 27, p. 23. This flare, and also that under the armpits, is

given by the insertion of gussets, so that we have a garment already wide in the skirt. It remains to tighten the body. This will necessitate seams in the centre back and front of the body as well as the tightening of side body seams. We arrive at a pattern of the type of Fig. 122*a* on p. 75. This is a reconstruction modelled on a lay figure and shows the right half of a fourteenth-century woman's dress, back and front pieces both shown. (Compare with dresses shown in wear on Figs. 172 and 189, pp. 101 and 107.) Fig. 122*b* on same page shows the underarm gusset sewn into place, and this enables the arm of the wearer to be lifted without tearing the garment at the armpit. Without this gusset, arm movements are impossible in a very tightly fitted bodice of the fourteenth century. The elbow-bend is made possible in the tight fourteenth-century sleeve by having the length from armpit to wrist cut several inches longer than the arm and then pushing the sleeve upwards, afterwards buttoning it tightly on the lower arm. In this way a zone of wrinkled superfluous length is concentrated at the elbow, so that the joint can move freely. A second design for shorter outer sleeves is also indicated on Fig. 122*a*, these may be seen in wear on Fig. 172, p. 101, also on Plate III.

Fig. 123 shows a further tightening up of the tunic or gown, and such a cut may be seen in wear on the two figures on Plate V. Fig. 124 is characteristic of the end of the century. The seams shown in the bodice part are clearly shown in a fifteenth-century painting in the National Gallery: "SS. Peter and Dorothy by the Master of S. Bartholomew." Fig. 124 gives the type of construction for the dress of Anne, Queen of Richard II., shown on Fig. 211, p. 115.

Fig. 125 is a late form of the surcoat which has now

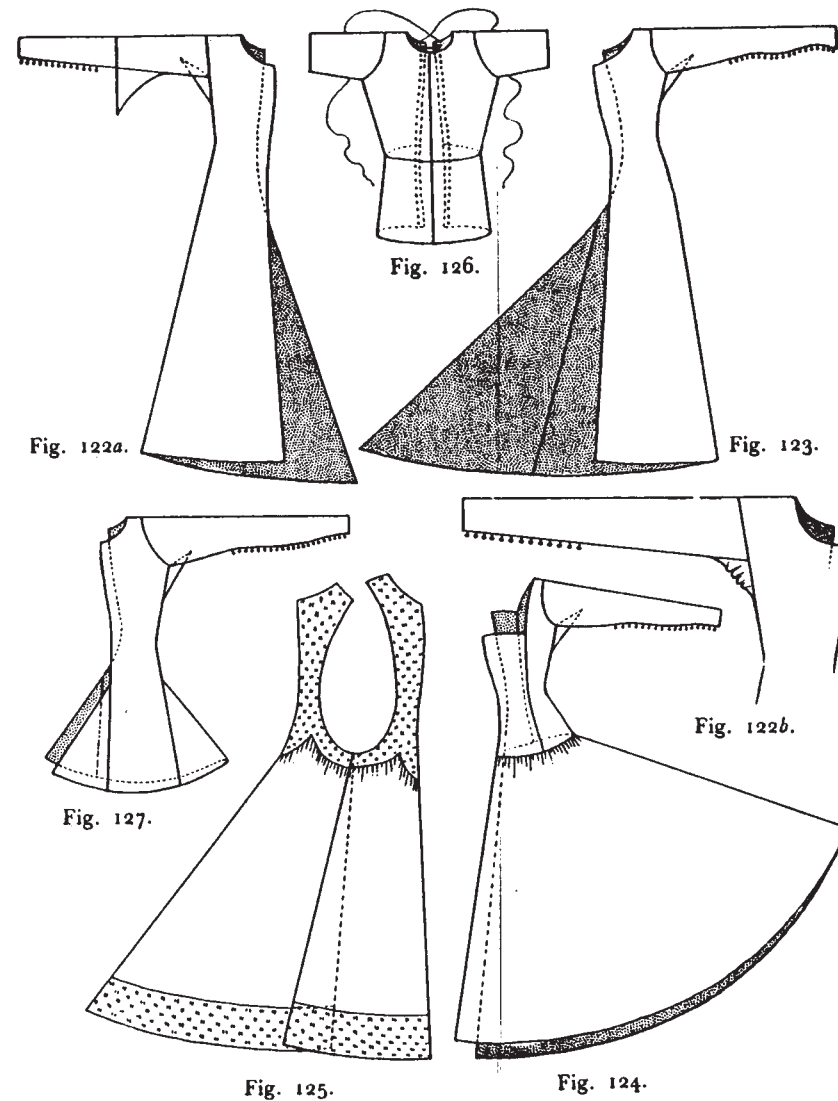

become so much modified in its upper part as to leave only a strip covering the body back and front. Fig. 125 (which is partly of fur) shows the back and front parts of the garment viewed from the right side. It is seen in wear on Jeanne de Bourbon, Fig. 213, p. 116, and in a slightly different form with a plain—not gathered—skirt on Fig. 191, p. 108.

Fig. 126 is a sketch of the cutting out of the "Jupon" or tight-fitting tunic of the Black Prince. This garment still hangs in Canterbury Cathedral. As will be seen, it has *short* sleeves (hence needs no gussets); it is laced down the back.

It is by no means certain, however, that this jupon was ever in actual wear, it may have been specially made to hang with the other "Atchievements" of the Prince upon the bar above his tomb. There is a reproduction in Shaw's *Dresses and Decorations of the Middle Ages* of a painting on the walls of St. Stephen's Chapel, Westminster, which shows the Black Prince in armour and wearing the jupon; in this painting there are no sleeves, neither are any shown on the effigy on the Canterbury tomb. On the other hand, a fourteenth-century jupon with sleeves is shown on the seal of Thomas de Holland, Duke of Surrey and Earl of Kent. During the fifteenth century sleeved jupons are common, and in a fresco at Brera, Milan, two knights (*circa* 1382) clad in the typical armour of the period wear long-sleeved jupons.

It is also interesting to note, in connection with the cutting of fourteenth-century men's tunics, that there is a fresco upon the walls of the Abbey Church of Pomposo (*circa* 1350), the subject of which is the "Entry into Jerusalem." Here men are seen to be pulling off their tunics to strew upon the ground, and the painting clearly shows that the tunics have a seam a few inches below the waist to

which a skirt part reaching almost to the knee is gathered. The upper part of the tunic is cut to fit the figure quite closely.

Fig. 127 shows the reconstruction of a man's tunic from the Luttrell Psalter. It is shown in wear in Fig. 171, p. 101. It will be seen that the wide effect of the skirt of the tunic has been achieved by the insertion of gussets at either side and in the centre back and front.

We now turn to a remarkable discovery of late fourteenth- or early fifteenth-century garments, which was made in Greenland in 1921. These garments are now in the Copenhagen Museum, and are considered to have been the costumes of members of an ancient Norse colony in Greenland. Fig. 128 shows the cutting of the right back and front of a man's loose or semi-fitting gown viewed from the side. It seems to have been similar in effect to that worn by Sir R. Braunché, Fig. 190, p. 107; refer also to Fig. 130. The elaborate and advanced system of cutting in this garment (Fig. 128) has astonished historians of costume. At the same time, if the pattern is studied, the portions A and B show the remains of the thirteenth-century tunic, while the gores at D and gussets at C and E have some similarity to the reconstructions given in Figs. 122*a*, 123 and 127.

It may be possible that material woven on a narrow loom would have suggested to the then tailor to cut out his costumes on this Greenland model of narrow pieces. It should be said that in the

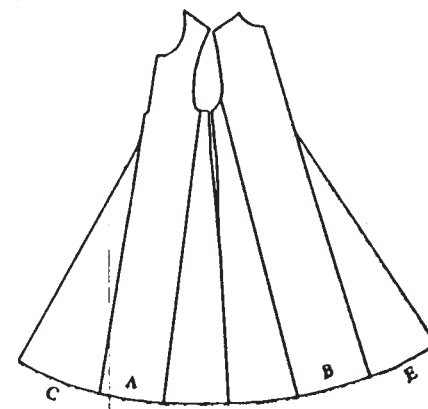

Fig. 128.



Fig. 129.

reconstructive patterns given in this chapter the widths of materials have been ignored, but the need for avoiding waste in cutting when materials were handwoven and necessarily expensive has not been lost sight of.

Fig. 129 is a similar view of the cutting out of a woman's full-length dress from the same collection as Fig. 128. It will be seen that under the armpit there are no less than four shaped gores to help to fit the figure tightly, while gussets are inserted centre front and back.

Fig. 130 is a reconstruction of the tight-fitting wide-skirted ankle-length tunic worn by Sir Robert Braunché, Fig. 190, p. 107. The wrinkles shown at the sides of waist in Fig. 130 indicate that the points A and B were originally close together and have been pulled apart for the insertion of a gusset (which latter has been split up as shown). This tunic would be similarly cut at the back, save that it might have a centre-body lacing and the body part tapered in to fit the back at waist.

Figs. 131*a* is the cape and 131*b* the hood, sewn to the cape, which is also worn by Sir Robert Braunché over his tunic. A hood of somewhat similar appearance was found with the Greenland man's costume (Fig. 128).

Fig. 132 is a reconstruction of the man's tunic, see Fig.

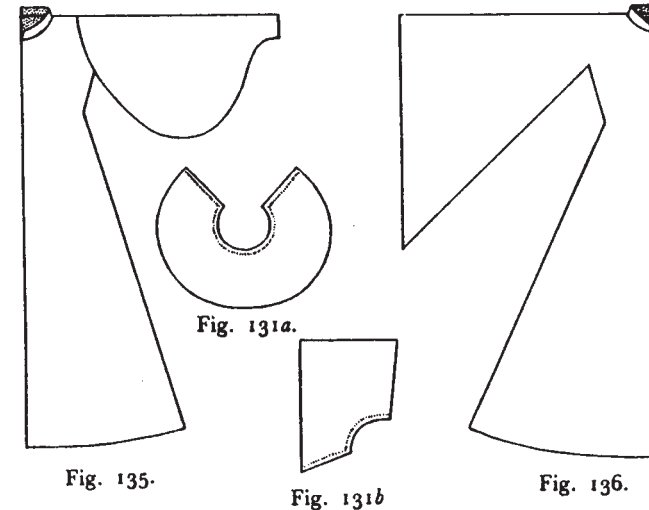

Fig. 135.

Fig. 131*a*.Fig. 131*b*

Fig. 136.

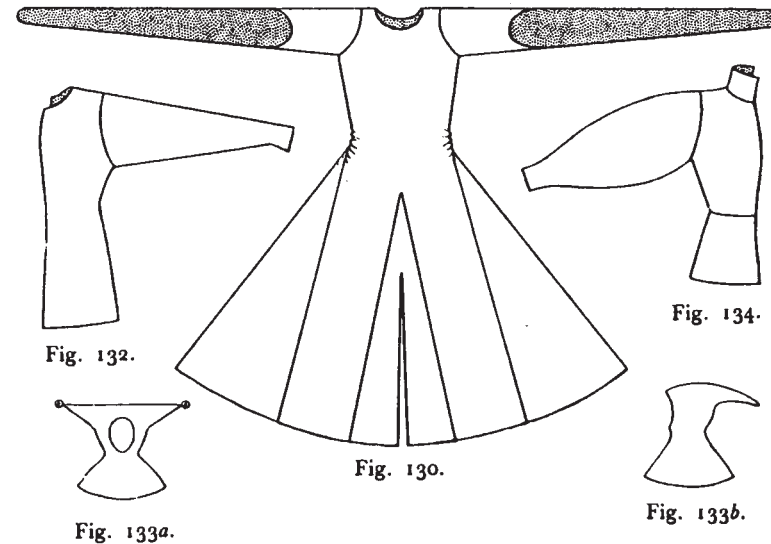

Fig. 132.

Fig. 130.

Fig. 133*a*.Fig. 133*b*.

Fig. 134.



Fig. 133c.

201, p. 111. The immensely long tail (liripipe) attached to this man's hood (which is cut after the manner of patt. 133*b*) on page 79 should be noted; he wears a steel head-piece over the hood.

Fig. 133*a* is another development of the hood which became the favourite headgear for Morris dancers and travelling mountebanks. It is seen

in wear on Fig. 133*c* which is from a Bodleian MS., No. 964 (after Strutt), dating 1344.

Fig. 133*b* (see also Figs. 186 and 222).

Fig. 134 shows a typical tight tunic as worn by men and now called the *côte-hardie* at the end of the century. It has balloon-shaped sleeves and the mace-bearer, Plate IV., wears a similar tunic.

Fig. 135 is an example of an early type of that loose gown, the *houppelande*, which became so immensely popular in the early fifteenth century. This particular model is that worn by the servant shown at Fig. 217, p. 119, but varieties of the early *houppelande* occur in Figs. 197 and 198. A later type is worn by King Richard II. in the Wilton Diptych, Fig. 209, p. 115, which is very similar in cut to Fig. 136.

King Richard's gown is not shaped at the waist like Fig. 136 but is cut with a single line slanting from armhole to hem.

There is little change in the men's hose or chausses from those worn in the thirteenth century, they were still tied to a belt, and short loose drawers concealed by the tunic

were worn, as shown on p. 51. It was in the fifteenth century that the hose were joined at the top so as to make what we now call "a pair of tights." There appears to have been a seam back and front of leg, and judging from the drawings great care must have been taken to ensure a good fit. Though the art of knitting at this period was not unknown, the hose seem generally to have been made from woven material instead of the "stockingette" such as is used for them to-day. See Fig. 316, p. 181.

OUT-DOOR GARMENTS

To go back to the beginning of the century we note the circular cloak in wear as heretofore. When worn by men it was sometimes slit and sometimes had a strip cut out at the right-hand side to give free play to the right arm. For the slit see Figs. 192 and 194 from the tomb of Edward III. and for the cut-out strip see the Italian, Fig. 215, p. 116. See also A, B, Fig. 137. Note the three buttons on shoulder. Both sexes wore the cloak open in front in style C, D. At times the opening G, D took the form of E, C, F, where the removal of this shaped piece from the front caused a charming cascade effect at either side as seen in Figs. 211, 212, p. 115. Another variety of the circular cloak was worn by men. This was open down the front and only reached to the bottom of the short tunic. It was buttoned closely from neck to hem and had a hood attached. Two of the figures of mourners round the tomb of Sir Roger de Kerdeston are thus dressed. A fine drawing of these figures is given in Stothard's *Effigies*, Plate 54. Lady de Northwode, Fig. 167, p. 98, wears the cloak without any slit whatever in

front, merely a hole large enough to go over her head (and head-dressing). She has, however, slits for her hands, see G and H on plan.

Figs. 138a and 138b show Lady de Northwode's hood. Fig. 138a as in wear except that all the buttons are buttoned down (they are left undone in Fig. 168). Fig 138b shows the cutting of hood clearly when folded flatly in two. It may be sewn to her cloak but her wimple or gorget hides the neck portion of the hood from view.

Fig. 139 is a survival of the traveller's cloak of the last century (called sometimes the *sclavine*). This pattern is a reconstruction of the gown worn by the Italian Standard-Bearer, Fig. 214, p. 117, the lappets at neck being a characteristic fourteenth-century effect. This cloak is also shown in wear on the young traveller, Fig. 165, p. 97, the date of which is not far from 1300, while Fig. 139 is late in the century.

HEADGEAR AND HAIRDRESSING

The headgear and hairdressing of the fourteenth century presents the student with a varied and elaborate pageant when it is compared with that of the hundred years preceding. At the same time it can in no way be likened to that of the peak period of exaggeration and variety which characterises the hundred years which follow.

THE MEN

General characteristics of their headgear did not vary so much or change so rapidly as did their body garments. Throughout the century we have the *hood* much in evidence

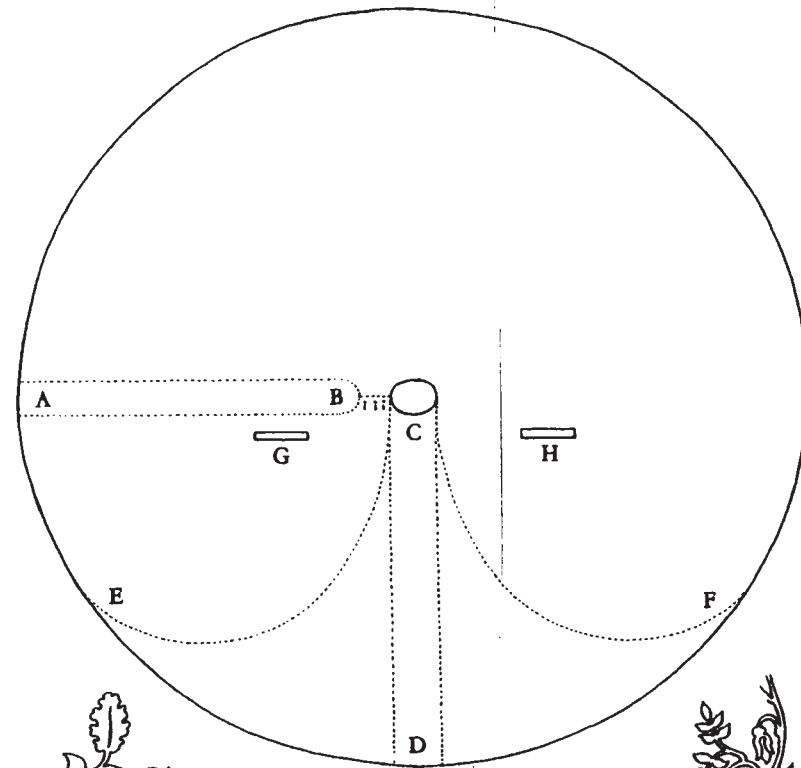

Fig. 137.



Fig. 140.



Fig. 141.

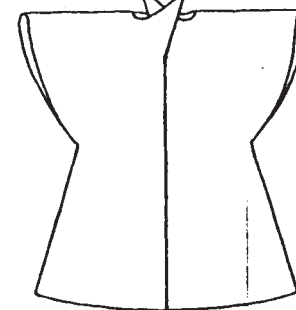

Fig. 139.

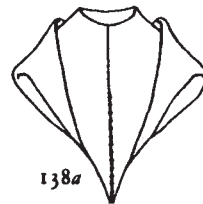

Fig. 138a.

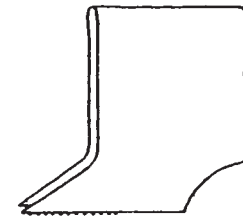

Fig. 138b.

and the favourite method of cutting was that already illustrated at Fig. 133*b*, page 79. The point at the back of this hood became gradually longer as the century progressed (and was named the "liripipe"), see Fig. 201, p. 111, then towards the close of the period this peak or point was caught up and twisted round the crown of the head, the whole hood becoming a species of decorative turban which took on varied and fantastic forms in the early fifteenth century.

The broad-brimmed *hat* and a hat with narrower brim is shown in a number of the illustrations here given of fourteenth-century costume, and it will be seen they were sometimes worn over the hood. At times they are small enough to be called *caps*. Planché tells us "beaver hats" are spoken of at this time and that they were probably made in Flanders. About the middle of the century we occasionally find a single long feather fixed in the front of a man's cap or hat.

The close-fitting skull-cap (or "coif") fastened under the chin, so common in the thirteenth century, began to be the distinguishing headgear of lawyers and was first made of white linen and afterwards of white silk.

MEN'S HAIRDRESSING IN THE FOURTEENTH CENTURY

The illustrations of the men's costume given, will show that the hair was not, as a rule, so elaborately curled as in the thirteenth century. Beards, when worn by men of middle age, were generally kept short and pointed, sometimes forked. Planché tells us that in the reign of Edward II. (1307-1327) "beards were worn by persons in years, great officers of state, and knights templars, but not generally."

WOMEN'S HEADGEAR IN THE FOURTEENTH CENTURY

Besides the headwear and hairdressing shown on the women's costumes illustrated, page 87 gives a series of styles indicative of the changes and developments which took place between 1300 and 1400. Recollecting that the large net, with or without the chin-band and circlet illustrated on page 47, was still the mode at the commencement of the fourteenth century we pass to two early fourteenth-century examples from MSS. in the British Museum, Fig. 142 (Sloane, 3983), p. 87. This lady, who by the way, is on horseback, is wearing her head-veil so that it serves for both veil and wimple combined. The veil is draped partly over and partly under a metal circlet, as seen in the drawing.

Her hair, underneath her veil, is dressed in precisely the same fashion as that of the lady on Plate III. (Luttrell Psalter, A.D. 1340). Her embroidered surcoat has been put on over the veil and covers the lower edge of the latter. Fig. 143 (Roy. 19, B.15) shows the wimple or gorget worn alone, leaving the top of the head uncovered. The hair is dressed over the ears in the "rams-horn" style, hence gives a large boss at each side over which the wimple is fastened by pins.

We now pass to the styles of women's headgear and dressing characteristic of the second half of the fourteenth century and take two plans of head viewed from the top, Fig. 144*a*, drawn by Stothard, and Fig. 145 by Hollis. These plans will give a key to the construction of Figs. 146 to 149 and also will help to explain what the back views of the other head-dresses, given with costumes of similar date, are like. Fig. 144*a* shows the top view of the head of the effigy from Canterbury Cathedral of Joan Burghersh, Lady Mohun, who died 1404. A veil covers the crown of

her head and falls down at the back ; it is kept in place by a jewelled circlet (see Fig. 144*b* for detail). The most important and characteristic part of the head-dress is in front ; this is a network, possibly of gold or gilded wire set with jewels, and enclosing the long hair which has been dressed in two plaits and brought round to the front (for this dressing, with two plaits, compare with the hair of Joan de Northwode, Fig. 167, p. 98). For the front view of a similar type of head-dress, compare with Figs. 146, 147 and 148. Fig. 146 is from the brass of Margaret Lady Cobham (A.D. 1395). Here, in place of the jewelled net, we see an arrangement of gathered material in three rows of gathers, these are gathers similar in effect to those lines called, in heraldry, *nebulé*, hence this particular type has been called the Nebulé Head-dress. Notice how the ends of the hair, after being crimped, are allowed to hang down and confined at the tips with two little bags of similar gathered material. Fig. 147 is from the brass of Sir R. de Malyns and represents one of his wives (date A.D. 1385). Here we have a head-dress very similar in its front view to that of Joan Burghersh (the top view of which is shown in Fig. 144*a*). On the other hand, the veil, instead of being fitted closely to the head, seems in this instance to be attached to the edge of the wire net. The zig-zag lines which here indicate the net have caused some writers to classify this head-dress as "the Zig-zag Head-dress," but others consider that the zig-zag lines are merely the engraver's method of indicating a net.

Fig. 148 is from the brass of Maud, Lady Cobham (date A.D. 1380). This head-dress has features in common with Figs. 146 and 147.

Fig. 145 shows the top view of the head of Philippa (Queen of Edward III.) who died in 1369. Here we see



Fig. 142.



Fig. 144a.



Fig. 143.



Fig. 147.



Fig. 146.



Fig. 144b.



Fig. 148.



Fig. 151.



Fig. 149.

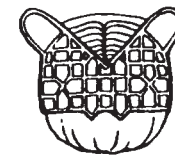

Fig. 145.



Fig. 150.

that interesting form of fourteenth-century head-dress called the *Crespine*. Its most characteristic features are the two jewelled cauls or nets of stiff gold wire which are semi-cylindrical in shape (see Fig. 145 for section, and 149 for front view). Compare with the hair of Lady Harsyck, Fig. 205. Fig. 149 is from the brass of Lady Burton (date A.D. 1382), Little Oasterton, Rutlandshire.

Fig. 150 is from the brass of Eleanor Corp (date A.D. 1391), Stoke Fleming, Devonshire. Here we have the *Reticulated Head-dress* in a form which became still more popular in the next century.

The whole head is covered with a jewelled net, a veil is draped over it, with a pointed effect in the centre front and hanging loosely down the back.

Another type of this *Reticulated Head-dress* which was also of frequent wear in the early fifteenth century is shown on the figure of the Queen Jeanne de Bourbon, Fig. 213, p. 116. This type has no veil, the net containing the hair shows a certain amount of bossing out at the sides, suggesting the hair worn in the "rams-horn" style but fairly flat. Fig. 151 is from a miniature bust in carved wood (Victoria and Albert Museum). This head, of a very young lady of the late fourteenth century, has the hair worn with a heavy tress crimped over each ear, each tress ending in a curl which is tucked behind the ear. The remainder of the hair hangs in a pigtail down the back.

While some attempt can be made to classify the head-gear and hairdressing into the aforesaid types, very many varieties exist of each of the styles given, in fact, no two heads seem absolutely identical, as will indeed be noted among the different illustrations which are given to illustrate the fourteenth century.

CHAPTER VIII

REGAL AND ECCLESIASTICAL COSTUME IN THE
FOURTEENTH CENTURY

REGAL COSTUME

WHEN describing regal costume in the fourteenth century, distinction must be made, as heretofore, between the semi-ecclesiastical royal vestments, such as are worn when the king is solemnly enthroned, those used for great occasions such as the opening of Parliament, and again those used in the ordinary civil life of the king and queen.

In this chapter, Fig. 152, p. 91, gives a drawing of the effigy of Edward II. (1307-1327) from his tomb in Gloucester Cathedral. His vestments are but little different from those of previous English monarchs, but the characteristic fourteenth-century streamer or "tippet" hangs from the sleeve of his dalmatic, which has in itself become longer and tighter than, for example, that shown in wear in the illustration of King John (Fig. 17, p. 13) in the thirteenth century.

Fig. 153, p. 91, is from the effigy of Edward III. (1327-1377) from his tomb in Westminster Abbey. He wears the usual number of royal vestments, but the fourteenth-century influence is shown in the sleeves of his under tunic, which, as will be seen, come down well below his wrists and are very tight. They are buttoned with the usual row of small buttons, though this does not show in the drawing.

The decoration of the shoes or buskins worn by the king is very rich, and is shown to a larger scale at Fig. 234, p. 127.

Numerous other examples of regal costume are illustrated in the fourteenth-century division of this volume, but they are described under the three chronological divisions—early, middle and late fourteenth century, whether they are of formal character or for ordinary occasions.

A table of the reigning monarchs in England, France and Germany is given, as heretofore, for convenient reference.

REIGNING MONARCHS IN ENGLAND, FRANCE AND GERMANY
THROUGHOUT THE CENTURY

<i>England.</i>	<i>France.</i>	<i>Germany.</i>
EDWARD I., 1272-1307. <i>m.</i> 1. Eleanor of Castile. 2. Margaret of France.	PHILIPPE IV. (le Bel), 1285-1314. <i>m.</i> Jeanne of Champagne, Queen of Navarre.	ALBERT, DUKE OF AUSTRIA, 1298-1308. <i>m.</i> Elizabeth Meinhard, daughter of the Duke of Carinthia.
EDWARD II., 1307-1327. <i>m.</i> Isabella of France.	LOUIS X. (le Hutin), 1314- 1316.	HENRY VII. OF LUXEM- BURG, 1308-1313. <i>m.</i> Constance.
EDWARD III., 1327-1377. <i>m.</i> Philippa of Hainault.	PHILIPPE V. (le Long), 1316-1322.	LOUIS THE BAVARIAN, 1314- 1347. <i>m.</i> Marguerite, Countess of Holland.
RICHARD II., 1377-1399. <i>m.</i> 1. Anne of Bohemia. 2. Isabella of France.	CHARLES IV. (le Bel), 1322-1328.	CHARLES IV. OF LUXEM- BURG, 1347-1378. <i>m.</i> 1. Daughter of the Elec- tor Palatine, and 2. Elizabeth of Pome- rania.
	PHILIPPE VI. (de Valois), 1328-1350. <i>m.</i> 1. Jeanne de Burgoyne. 2. Blanche of France.	WENCESLAUS, KING OF BOHEMIA, 1378-1400. <i>m.</i> Jeanne.
	JEAN II. (le Bon), 1350- 1364. <i>m.</i> 1. Bonne of Bohemia. 2. Jeanne, Duchesse de Bourgoyne.	
	CHARLES V. (le Sage), 1364-1380. <i>m.</i> Jeanne de Bourbon.	
	CHARLES VI. (le Bien- Aimé), 1380-1422. <i>m.</i> Isabeau of Bavaria.	



Fig. 152.

EDWARD II. FROM
GLOUCESTER CATHEDRAL.



Fig. 153.

EDWARD III. FROM
WESTMINSTER ABBEY.

EXAMPLES OF ECCLESIASTICAL COSTUME

The vestments of the Church during the fourteenth century show but little change from those of the thirteenth. One of the few developments is seen in the increased height of the bishop's mitre. It will not, therefore, be necessary at this stage to add to the enumeration and description of the various vestments, and it will suffice to postpone further elucidation of these details till the fifteenth century; proceeding with a description of the illustrations here given of

fourteenth-century ecclesiastical costume, we may note that as four out of five of these examples, together with other illustrations of civilian dress and armour, are taken from *Memorial Brasses*, it will be well to draw attention to this most important source of information for fourteenth-century costume. Most of our great museums contain facsimiles of a great number of the best specimens, and there is a mass of valuable literature on the subject (for which latter, see list at end of book). The Victoria and Albert Museum, South Kensington, has a fine collection of facsimiles, and also an illustrated catalogue, accessible to those who cannot visit the Museum.

The specimens of ecclesiastical costume from brasses here given are arranged according to date.

Fig. 154, p. 93, is from the brass of Laurence de St. Maur, 1337, priest and rector, Higham Ferrers Church, Northants. His vestments (the construction of which has been explained on pp. 22-30) are clearly seen, namely, the amice, alb, maniple, stole and chasuble. The figure, as in most memorial brasses, is intended to be *recumbent*, hence he is not *standing on* the two little dogs, who are quarrelling over a bone, they are merely *at* his feet (these are, however, a most unusual feature on the tomb of a priest, in fact, probably unique). The quatrefoil decorations on the lower "apparel" of the alb and on the stole and maniple show the love which the fourteenth-century designers had for these geometric patterns which seem to be taken from contemporary architectural decoration.

Fig. 155 is from the brass of Nicholas of Louth, Rector of Cottingham, Yorks, 1383. He wears the *cappa nigra*, a black choral cope (worn over surplice and cassock by the Augustinian canons). He also wears the almuce with its



Fig. 154.



Fig. 155.



Fig. 156.

characteristic tails. These three garments—*surplice*, *cassock* and *almuce*—are explained on pp. 149 and 150.

Fig. 156 is from the brass of Richard de la Barre, 1386, in Hereford Cathedral. He wears an embroidered cope, with morse, a pleated surplice and an almuce.

Fig. 157 is from the brass of Robert de Waldeby, Archbishop of York, 1397, in Westminster Abbey. He is in the full vestments of his order, which have already been explained in a previous chapter.

Fig. 158 is from a French late fourteenth-century MS. (Add. 23145 f. 33b) in the British Museum. It represents St. Nicholas dressed as a bishop of the period. He is wearing a long surplice surmounted by a cope which appears to be of soft material and which is fastened by a metal brooch or



Fig. 157.



Fig. 158.

morse. Points which should be noted about this figure, which are characteristic of the fourteenth century, are: (1) The greatly increased height of the mitre and the slight curving out of the sides of its peak. (2) The flame-like quality of the foliage which springs from the head of the bishop's crosier or pastoral staff. These foliations should be compared with those of the thirteenth century as the two styles show distinct characteristics.

The original drawing in the MSS. is very minute, which accounts for the lack of detail in this illustration.

CHAPTER IX

CIVILIAN DRESS IN THE FOURTEENTH CENTURY

As in the thirteenth century the changes of fashion are more evident in the dress of the wealthier classes than in that of humbler folk. The division of the century into Early, Middle and Late for the purpose of getting a clear view of the trend of styles has been already referred to in Chapter VII. With this idea in mind a group of illustrations dating between 1300 and 1340 will give the essentials necessary to identify the period.

EARLY FOURTEENTH CENTURY

Figs. 159, 160 and 161, a dancer and two musicians, are from a British Museum MS. (Stowe 17). Flemish, *circa* 1300. Here we see three costumes which retain the characteristics of the late thirteenth century. Fig. 160—The Dancer—exhibiting the typical netted hair and tightened tunic, while the shoes of the two musicians are becoming longer and more pointed in the toes than was general in the thirteenth century. The colouring in the original is as follows: Fig. 159, tunic parti-coloured, half-blue, half-fawn, stockings red, shoes black. Fig. 160, tunic or gown parti-coloured, red and white, shoes black. Fig. 161, tunic greenish-blue, hose black. Notice the beginning of the fashion of parti-coloured garments, such a favourite effect in the fourteenth century.



Fig. 159

Fig. 160.

Fig. 161.

Figs. 162 and 163 are from a British Museum MS., *circa* 1300 (Add. 28162). The figures represent a charitable lady pouring some oil from her store into a vessel held by a poor man. Her head-dress is in the style of the close of the thirteenth century, also her tunic and surcoat. The head-dress is white, tunic red, surcoat blue.

Fig. 164, from a British Museum MS. (Roy 14E, III.), French, early fourteenth century, shows the figure of a queen with flowing hair, veil and crown. Note the close-buttoned sleeve, an early example of this favourite fourteenth-century mode of sleeve-fastening.

Fig. 165—from the same MS. as Figs. 162 and 163—



PLATE III. LADY AND YOUTH TALKING: EARLY FOURTEENTH CENTURY

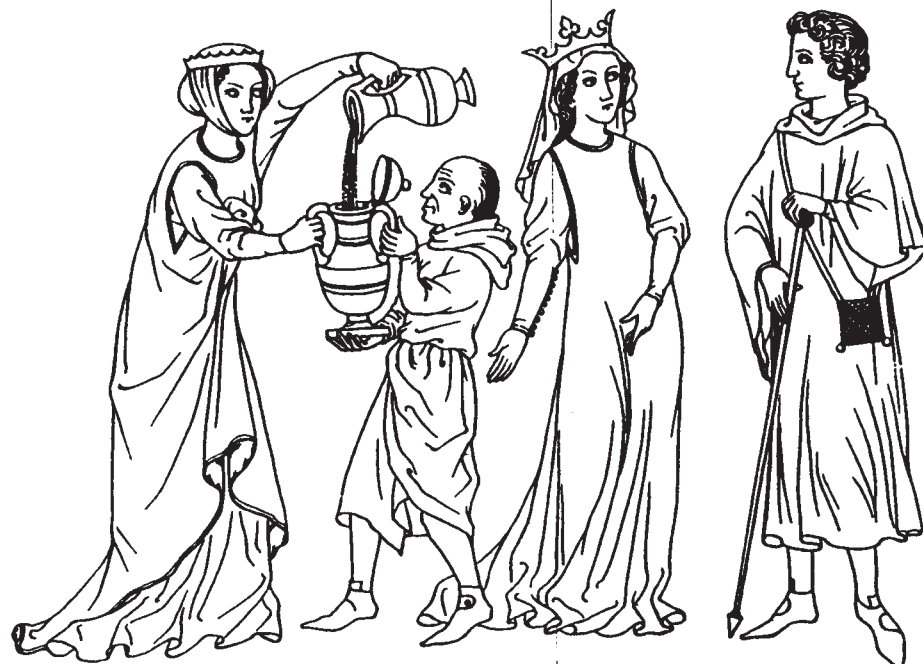

Fig. 162.

Fig. 163.

Fig. 164.

Fig. 165.

may be described as the costume of a traveller. The figure which has wings and a halo in the original, represents one of the three angels who, we are told in the Biblical story, visited Abraham.

Fig. 166 is from the memorial brass of Margarete de Camoys at Trotton, Sussex, date *circa* 1310. She wears a loose robe with short sleeves and under it a tighter one with the characteristic tight-buttoned sleeves. Her head and neck are covered with the veil and wimple. She wears a metal fillet across the forehead and two side curls. The nine small blank shields on her robe mark the place where shields of coloured enamel were inserted which have now disappeared.



Fig. 166.



Fig. 167.

This simple dignified costume is altogether typical of the dress of a middle-aged or elderly lady in the first quarter of the century.

Fig. 167 is from the brass of Joan de Northwode at Minster, Isle of Sheppey, *circa* 1330. The most striking feature of this costume is the circular cloak, with opening in the centre only. The plan of this cloak has been described in Chapter VII., page 82. Her hood is also explained on page 82, Figs. 138*a* and *b*. This hood is lined with a lining of "vair" or variegated fur. Her gorget, or wimple, is apparently stiffened round the top with a wire and pinned on to her hair. Notice the disappearance of the veil on this figure, and compare the hairdressing with those on page 87.

No figures of agricultural workers have been given in the "Early" division of the fourteenth-century styles, as it may be taken they are almost completely similar to those of the thirteenth, but in the next or "Middle" period numerous examples are given which will sufficiently illustrate the whole century.

MIDDLE FOURTEENTH CENTURY

The emergence from the thirteenth century and the beginning of the mid-fourteenth century period can be adequately viewed in the Luttrell Psalter. This magnificent manuscript, now in the British Museum (Add. 42130), is dated *circa* 1340, and gives a very complete picture of the life of East Anglia at the time. We see Sir Geoffry Luttrell, Fig. 168, on his horse, attended by two ladies, Figs. 169 and 170; for the description of Sir Geoffry himself, see Chapter X., pp. 123 and 124. Fig. 169, Lady Luttrell, born Agnes Sutton, wears a surcoat over her tight inner gown. The surcoat, which is here drawn in outline, is decorated in the original with the Luttrell Arms (for Luttrell Arms, see pp. 134 and 137) impaling those of Sutton (for Sutton "or, a lion rampant vert"). The second lady similarly dressed is Sir Geoffry's daughter-in-law, born Beatrice Scrope; she wears a similar surcoat of Luttrell impaling Scrope of Masham (azure, a bend or, a label of 5 points argent). Figs. 168 to 170 are decorated in the richest manner with delicate patterns in outline in addition to the heraldic bearings. A description of these patterns will follow in the chapter on fourteenth-century ornament.

Plate III. also from the Luttrell Psalter. Here we have the costumes of a young lady and her lover. The chief

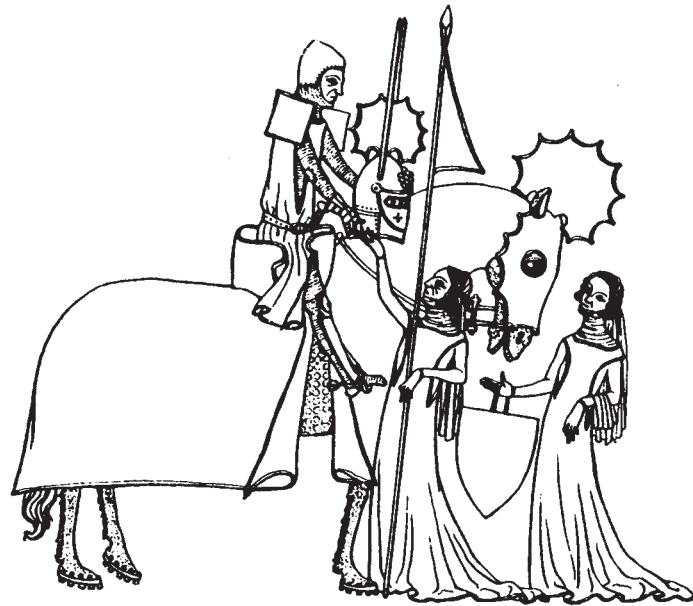

Fig. 168.

Fig. 169.

Fig. 170.

points to notice about both figures are the hanging sleeves of their outer tunics, the indications of embroidery on the lady's dress and the man's hood, and also the gaily striped pattern of his tunic.

Figs. 171-173 give us three more costumes from the Luttrell Psalter. Fig. 172 is that of a man watching the progress of a game. We can notice that the point of his hood is longer than in the thirteenth century, also the toes of his shoes are much more pointed. His tunic has been already explained in Fig. 127, p. 75. Fig. 172, a lady playing a musical instrument, shows sleeves similar to those in Plate III., and an early example of the fashion of buttoning the gown down the front is seen in her case. Her hair is

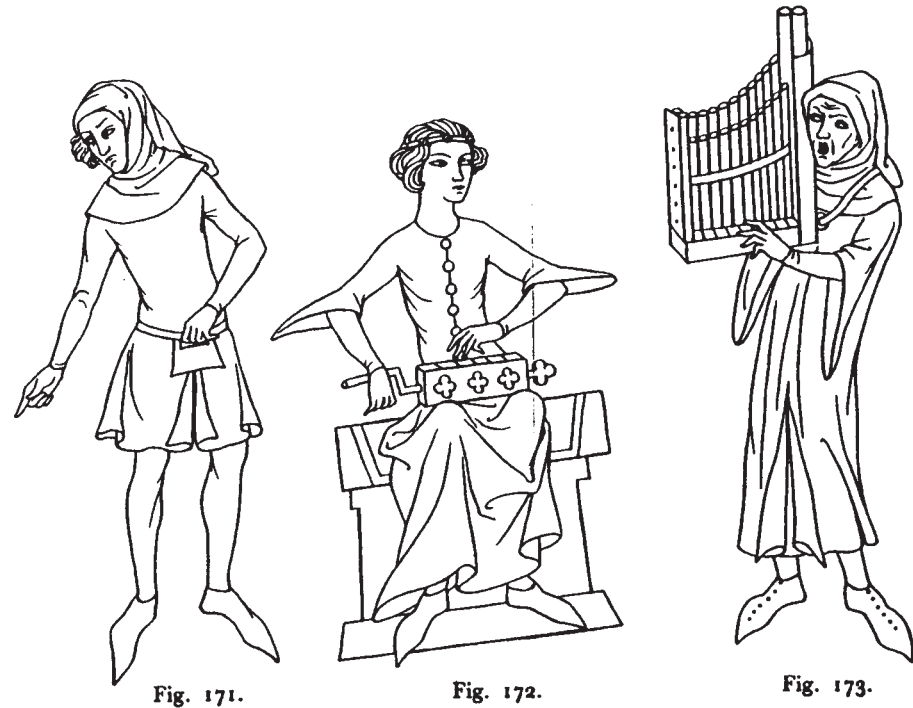

Fig. 171.

Fig. 172.

Fig. 173.

probably arranged at the back in similar fashion to that of Lady Luttrell. Fig. 173 wears the typical loose gown introduced early in the fourteenth century; compare this with the gown of King Edward II., Fig. 152.

WORKING-CLASS COSTUME

Fig. 174 is from an early fourteenth-century British Museum MS. (Sloane 3983). This girl, holding distaff and spindle, shows an interesting method of tucking up the surcoat and the under-dress. Figs. 175-177, three working women from the Luttrell Psalter. It will be seen two of them are wearing aprons. From the Luttrell Psalter,

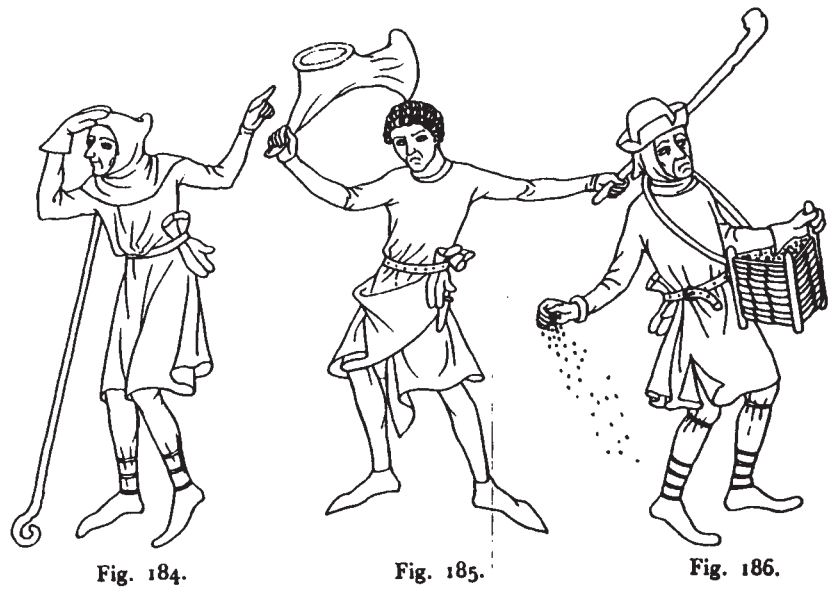
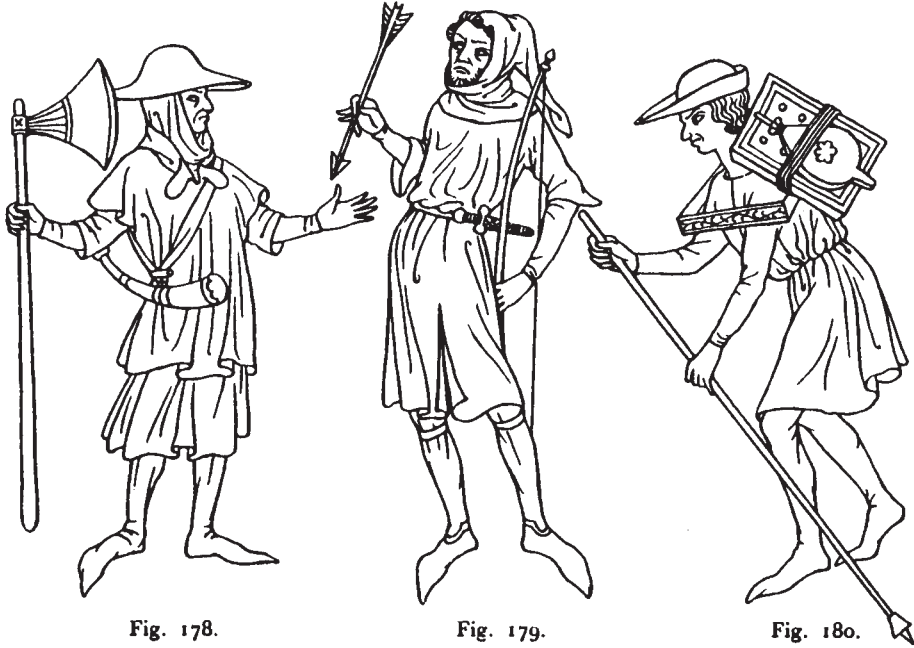
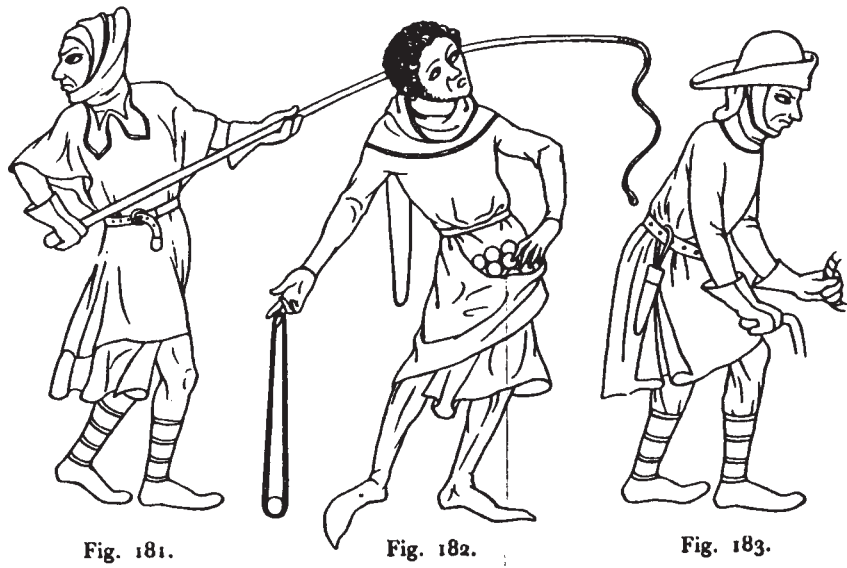

also Figs. 179–187. Fig. 178, a man with axe and hunting-horn wears a wide-brimmed hat over his hood. He has a short form of the sclavine with lappets and an extra hood attached to his outer tunic. His hose fit rather loosely.

The bowman, Fig. 179, wears garters to keep his hose in place. Fig. 180 is a travelling tinker, carrying the tools of his trade. His hat is similar to those worn by pilgrims. Fig. 181 drives a team of oxen. Fig. 182 aims a stone at some crows. Fig. 183 holds the plough drawn by four oxen. Fig. 184, a shepherd. Fig. 185 waves his hood to scare away a hawk threatening a flock of young geese. Fig. 186 scatters the seed from a square basket. The last illustration from the Luttrell Psalter, Fig. 187, is that of a man on horseback holding a hawk on his gloved left hand. A tabor, with curved drumstick (presumably for putting up the birds) hangs from his girdle.

The set of illustrations from this great manuscript serve as a preparation for the *fully developed* style of the mid-century.



Fig. 187.

The elaborately dressed figure of a young king, Fig. 188 (one of the Magi), carrying his precious gift in a ciborium and holding a sceptre decorated in the architectural manner, in which the fourteenth-century artists took such joy, is from a wall painting at St. Stephen's Chapel, Westminster, and is dated 1350–1356. It was fortunate that drawings had been made of what remained of these paintings before St. Stephen's Chapel was burnt in

the year 1832. The Society of Antiquaries had commissioned the artist Smirke to make drawings from the originals just previous to the disaster. A set of these drawings are in the Print Room at the Victoria and Albert Museum. In examining the costume of this figure we can see that the whole silhouette has become slimmer, the belt has moved down over on the hips. The tunic is buttoned closely all down the front. The long-pointed shoes are embellished with an architectural design in pierced leather comparable to the "rose" window in a Gothic cathedral, in fact the "little Paul's windows" referred to by Chaucer.



Fig. 188.

The circular fur-lined cloak and short fur cape surmounting it can be compared with those on the figures of St. Edmund and St. Edward the Confessor on page 113. The foliations on the crown show a far more elaborate and at the same time freer character than the severe thirteenth-century decoration.

Figs. 189 and 190 are from the brass of Robert Braunché

and his two wives Letitia and Margaret at King's Lynn, Norfolk. The date is 1364. As will be seen the husband and wife are dressed in not dissimilar fashion. The man's tunic has already been given in plan, see Fig. 130, p. 79, also the small cape and hood, see Figs. 131*a* and 131*b* on same page. It has also been remarked that the cutting out of the Greenland dresses, Figs. 128 and 129, would give results similar in appearance to those on this brass.

The rich decoration on the dress of Letitia Braunche may be embroidery, but it is also interesting to compare it with the woven silk pattern, see Chapter XI., p. 130. From the elaborate detail it is thought that this brass may have been executed in Lubeck and imported into England. The usual lapdog is at the lady's feet, but at the feet of the man a hairy savage is struggling with a monster.

Slightly later in date and showing perhaps the most typically fourteenth-century style of the whole period is the set of illustrations shown on Figs. 191–195, p. 108. These are the children of Edward III. (who died in 1377), from his tomb in Westminster Abbey.

Fig. 191, Mary, Duchess of Brittany, has a head-dress very similar in style to that of Eleanor Corp (Fig. 150, p. 87). Her surcoat has developed into a totally different garment from its thirteenth-century ancestor. Her girdle—which the low-cut sides of the surcoat permit to be seen—is low on the hips. Her skirt is becoming fuller—a forecast of the style of the late fourteenth century.

Fig. 192, The Black Prince. His cloak is explained at Fig. 137, p. 82. Note that the circle in this case is gathered in at the neck. Probably sewn into a band which the hood covers. The hem of the cloak is an early example of that scalloped or “dagged” decoration which was to run riot



Fig. 189.

Fig. 190.

on the fashionable garments of later fourteenth and early fifteenth century.

Fig. 193 is the effigy of William of Hatfield, who died while still a boy. There is another effigy of this prince in York Cathedral, and here the tunic is richly decorated with

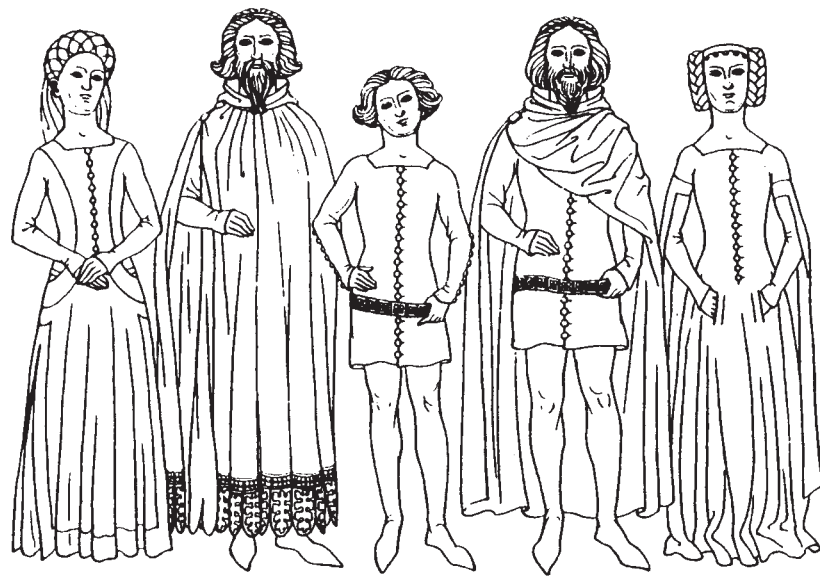

Fig. 191.

Fig. 192.

Fig. 193.

Fig. 194.

Fig. 195.

beautiful scroll-work representing embroidery, also there is a circular cloak worn with four large jewelled buttons on the right shoulder and upper arm. The entire edge of this cloak is dagged or scalloped in the most elaborate manner with a conventional leaf pattern.

Fig. 194 is that of Lionel, Duke of Clarence. In this case the cloak fits plainly at the neck, where it is covered by a hood.

Fig. 195 is an effigy of Joan of Castile. This costume presents several typical and interesting features of the latter half of the century, and as a style it can be said to have prevailed very widely. The hairdressing can be compared with that of Lady Harsyck, Fig. 205, p. 112. The "tippet" on the sleeves are developed from the earlier style which can be seen on the figures of Sir Robert Braunche and his



PLATE IV. HERALDIC COSTUMES: LATE FOURTEENTH CENTURY

wife (Figs. 189 and 190, p. 107). The vertical pockets or slits are also a distinguishing mark of this period and of the commencement of the succeeding one.

LATE FOURTEENTH CENTURY

In England this period corresponds with the reign of Richard II., 1377-1399.

Beginning with Figs. 196-200, we get a set of contemporary costumes from the British Museum MSS. (Roy. 19 D2). Here, in the costumes of the boy and two men, the belt is at its lowest and the garment at its tightest. The shoes continue very long and pointed in the toe. The hoods worn by Figs. 197 and 198 seem to have taken the form of capes or "tippets," cf. Figs. 267 and 270. The two ladies, Figs. 199 and 200, are dressed very much in the style of Fig. 195, with the exception of their hairdressing, which has reverted to the types worn earlier in the century. Compare with the heads of Lady Luttrell and her daughter-in-law on page 100.

Figs. 201 and 204 are from a British Museum MSS. (Add. 23145, French, late fourteenth century). Fig. 201 is a bowman who wears a parti-coloured tunic in blue and white, his hose are one pink and one blue. His hood, with its long liripipe, is pink, and he wears a *chapeau de fer* or iron hat of war over it. The armholes of the tunic are very large, hence the sleeves also become wide towards the armhole. Fig. 204, who carries a club, wears a long padded and quilted tunic in red, a *coif-de-mail* or hood of chain mail shows under his iron hat of war. Chausses of the same mail are on his feet, his legs are in plate armour; for a further explanation of his costume, see Chapter X.

Figs. 202 and 203 are from a very well-known British Museum MS. (Roy. 20 B. VI., date 1395-1396). The page from which these costumes are taken depicts Philippe de Maizières presenting his book to King Richard II. (enthroned). These two courtiers, Figs. 202 and 203, are standing on the King's left and, together with the bearded figure on Plate V., are considered by some writers to represent his uncles, the Dukes of Lancaster, York and Gloucester.

The immensely long-pointed toes which are to be seen on the hose of all three figures mark the time when this fashion was tremendously exaggerated, shoes of this type being named "cracowes" (probably after the town of Cracow, which town was part of the domain of the then King of Bohemia, father of Anne of Bohemia, wife of Richard II.). Another name for these long shoes was "poleynes." Fig. 202 is wearing an early type of houppelande, with sleeves much smaller than is found in later examples. Fig. 203 is wearing a tunic which has entirely altered in character from the sheath-like, mid-century types. Here the belt has moved upwards to the waist again, and an early example of the "poky" or "bag" sleeve is shown.

Fig. 205 is that of the wife of Sir John Harsyck, from their brass at South Acre, Norfolk, dating 1384. This is a fine example of the heraldic dress so popular in the fourteenth century. Lady Harsyck wears her own arms, impaled with those of her husband, embroidered upon her dress. The heraldic description is as follows. For Harsyck, "Or, a chief sable, indented of four points." For "Gestingthorpe" (arms which had been assumed by inheritance in Lady Harsyck's family), "Ermine, a manche gules." The head-dress of this figure to which reference has already been made, together with the cloak and long tunic, are of a type

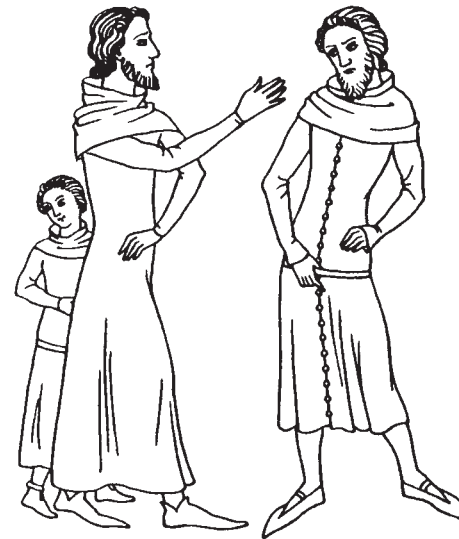

Fig. 196. Fig. 197.

Fig. 198.



Fig. 199. Fig. 200.



Fig. 201.

Fig. 202.

Fig. 203.

Fig. 204.



Fig. 205.

Fig. 206.

vergne, Comtesse du Foret, 1370-80 and (the train-bearer) La Dame de Nedouchel.

Figs. 207, 208 and 209 are from the celebrated Wilton Diptych, of which the date is considered to be approximately 1381-82.

Fig. 207. St. Edmund, is wearing a houppe-lande with fairly long sleeves, under his ermine-lined, ermine-caped

very frequently seen in wear from the middle right up to the end of the century, though towards 1400 new styles invaded this sheath-like gown with its long buttoned sleeves and the cloak over it, the latter, of a design a century old, never quite disappeared.

Plate IV. shows two French heraldic costumes of the late fourteenth century. They are drawn from an illustration in Jacquemin's *Iconographie*. He describes the figures as being those of Anne, Dauphine d'Au-



PLATE V. MACEBEARER AND COURTIER : END OF FOURTEENTH CENTURY

cloak, which is, of course, of circular shape. His inner sleeves come down well over the wrists. The cloak is green, the houppelande is deep blue, with a pattern of golden birds linked together by golden crowns. His hose are of scarlet, the sleeves of his inner garment plain blue.

Fig. 208. St. Edward the Confessor, is dressed in similar fashion to St. Edmund save that he wears a long cream-coloured gown in place of a houppelande; his cloak is also cream-coloured but his inner sleeves—the one touch of colour in his whole costume—are of deep blue; a beautifully-dignified ensemble.

Fig. 209. Richard II. when a youth of fifteen. He wears a scarlet houppelande which is entirely covered with a golden embroidered pattern consisting of his badge (a white hart) enclosed in ornamental circles, for further description of which see Chapter XI., pp. 133–135. He also wears a jewelled collar of links in the shape of broom-pods while a morse or brooch is fastened into the front of his garment and takes the form of a white hart in gold and enamel or perhaps in mother-of-pearl, and with golden jewelled antlers. The neck and sleeves of the houppelande are trimmed with a gold braid and on the sleeves the braid is fringed. The National Gallery of London, where the Diptych now is, have published a fine



Fig. 207. Fig. 208. Fig. 209.



Fig. 210.

coloured reproduction of this picture, giving an adequate idea of the splendour and elaborate decoration of the garments shown here in outline.

Fig. 210 is from the portrait of Richard II. in Westminster Abbey, which is said to have been painted to commemorate the visit of the king to the Abbey in 1390, though other authorities consider it may have been painted (after his death) in the early fifteenth century. It represents the king in his royal robes with a crown, orb and two sceptres. The detail has been injured by various "restorations," now removed. He is seated in a chair of state, wearing cape, cloak

and a long tight-fitting deep-blue gown which is embroidered all over with a pattern in gold composed of his initial R, surmounted by a crown alternated with a foliated rosette. The cape is of ermine, as also the lining of the crimson cloak.

Figs. 211 and 212 are those of Richard II. (as he appeared at the close of his reign) and of his wife, Anne of Bohemia. The figures are said to be dressed in "Parliament Robes." In Westminster Abbey these figures are recumbent and, owing to the height of the tomb on which they lie, rather difficult to see. They have, however, been very carefully drawn by Hollis, who shows all the elaborate patterns upon the robes. Figs. 211 and 212 have been drawn here in outline only, but

in Chapter XI. these patterns decorating the robes are shown to a large scale and fully described. Points to note in Fig. 211 are the simple free-flowing hair, a coiffure sometimes affected by queens at this period, as in the previous century. There is also evidence that the body and skirt of the queen's dress are separately cut and sewn together at the hips. The cloak—like the king's—is cut away at the front and gives the cascaded effect referred to in Chapter VII., see Fig. 137, E C F.



Fig. 211. Fig. 212.

Unfortunately the hands and arms of both figures have been lost, but in this drawing they have been "restored," the deficiency being made good from a similar pair of figures in a memorial brass of the period. There is little to note in Fig. 212 excepting that the king's gown is loose and almost monk-like in character, as is also the hood.

Fig. 213. This drawing is from a statue of Jeanne de Bourbon, Queen of Charles V. of France; it is one of two statues which decorate the chimney-piece of the Grande Salle of the Palais de Justice at Poitiers. The queen's head-dress consists of a coronet or crown over a richly-jewelled net or caul. Her costume includes a late form of surcoat (now called *super-côte-hardie*) with the body part formed entirely of fur, also fur bands at the sides to which the skirt part



Fig. 213.



Fig. 214. Fig. 215.

is gathered. The jewelled hip-belt shows at the sides and the front of the surcoat is composed of a series of square jewelled brooches of very similar character to the belt. The sleeves, which are probably tightly buttoned, come well down below the wrist.

The history of the fourteenth century is full of references to the enterprise of Italian merchants, and their visits to England were frequent, owing to the popularity of English wool on the continent of Europe. Figs. 214 and 215 are taken from an Italian MS. in the British Museum, of late fourteenth-century date (Add. 27695), and they might be said to illustrate the probable costume of two Italian merchants. There is nothing to note here which has not been

already explained, but the manner in which Fig. 215 is wearing his capuchon or hood twisted upon his head may be taken as an "advance fashion" of the early fifteenth century.

No woman's costume of the Religious Orders has been given to illustrate the fourteenth century, as there is little or no difference between them and those of the last hundred years. The dress of the various Orders which were founded between 1300 and 1400 are to be found in the specialised books on costume of the Religious Orders (see list at end of book).

Fig. 216, however, may be said to have almost the character of a Religious Habit. It is from the brass of Alianore de Bohun, Duchess of Gloucester, 1399, St. Edmund's Chapel, Westminster Abbey.



Fig. 216.

She was the wife of Thomas of Woodstock, youngest son of Edward III., whom she survived. Her heavy veil and wimple (or barbe) proclaim the widow. This development of the wimple—the barbe—hung down like a beard and was gathered or pleated into a chin band. The barbe was essentially a mourning habit, and late in the sixteenth century the exact method of wearing it above or below the chin was regulated according to rank. For example, from a baroness upward, it was worn above the chin, and by those of lower rank, under the chin. It still survives in the costume of some of the modern Religious Orders.

Plate V., as has been said, is from the same MS. as Figs. 202 and 203. The young man who is holding a mace,

wears his belt low on the hips after the earlier manner, but his high collar and bag-sleeve are markedly different from the collarless, tight-sleeved tunics of earlier date. The absence of the capuchon or hood should be noted. The older figure, whose hat is doffed in the presence of his King, shows, in common with the figure of the mace-bearer, the fashion of parti-coloured hose or chausses which began to be cut much higher at the top as the tunic (now called *côte-hardie*) became shorter, cf. Fig. 224. The jewelled garter upon his leg may be intended by the French artist for the "Garter" of the English Order of that name; but, if so, the representation is, of course, quite inaccurate. For description and correct drawing of the Garter, see Fig. 342a, p. 207.

Towards the close of the fourteenth century a young man in the height of the fashion, as, for example, the youthful squire in the Canterbury tales, would array himself after the manner of the courtier in Plate V., but with the sleeves perhaps a good 12 inches longer and "dagged" at the edges. These long bell-shaped sleeves emphasised, by contrast, the slimness of waist and hips. We are told by Chaucer that "his *côte-hardie*" with wide sleeves was embroidered "like a meadow" full of red and white flowers. A truly gay and elegant figure he must have been and some idea of the flowery embroideries may be gained by consulting Fig. 345, p. 210.

We now come to that type of dress which marks the close of the century, and it will give an excellent idea of the style and silhouette if we view a series of contemporary costumes from one manuscript in the British Museum (Roy. 1 EIX., late fourteenth century). Figs. 217 to 225 are, it will be seen, drawn from varied walks in life. Fig. 217, perhaps the most



Fig. 217.

Fig. 218.

Fig. 219.

Fig. 220.

Fig. 221.

"advanced" in style, is that of a servant waiting at table. He wears the *houppelande*. Its collar is not so high as was common in the next century. His sleeves are of the "poky" or "bag" variety.

Fig. 218 represents an elderly king. Compare with examples of fourteenth-century royal costume, and it will be seen his bell-shaped sleeves strike a new note.

Fig. 219 wears hood, cape, cloak and long, tight-fitting gown with full skirt. The hair is flowing, like that of several other queenly coiffures in previous illustrations.

Fig. 220, lady-in-waiting on the queen, wears the *houppelande* in its essential form, though the sleeves are short compared with those of the next two decades.

Fig. 221. The long gown of this second court lady shows new features. The neck is lower than any of the previous types—the *body* part only of the gown is tight-fitting, the



Fig. 222.

Fig. 223.

Fig. 224.

Fig. 225.

skirt part is very loose and full, and the whole garment has a high-waisted effect. The charming simplicity of the garlanded hair of these two young lady attendants, while unusual, is found occasionally all through the thirteenth, fourteenth and fifteenth centuries.

Fig. 222. A jester has the lower part of his tunic quilted and padded, and there is a seam joining the upper and lower halves together at the waist. His hood is joined to his tunic at the neck. No method of fastening this tight tunic is indicated in the original manuscript, probably because the drawing is on such a small scale. We may assume that the fastening would be most likely to be in front; it might, however, be at the back or even at the sides.

Fig. 223 shows the dress of a youthful student or scholar. He wears what seems to be a houppelande of only knee-length, which has bag sleeves. On his head a twisted roll of material gives the impression of a turban.

Fig. 224 is a servant in outdoor dress. He wears the hood



PLATE VI. COURT COSTUMES : LATE FIFTEENTH CENTURY

with pendent "liripipe" characteristic of the mid-fourteenth century, but his bag-sleeves and very short tunic, with its waist seam and padded quilting below the waist, mark the date as being towards 1400.

Fig. 225, a reaper. Here we see in part the conservatism of agricultural costume. The hat and shoes might be thirteenth century, but the collar and sleeves of the tunic again mark the date as late fourteenth century. Figs. 222-225 are from the British Museum MS. Roy. 1. E. ix.

CHAPTER X

ARMOUR IN THE FOURTEENTH CENTURY, AND
DETAILS FROM METAL ORNAMENTS

THE armour of the fourteenth century is notable as giving us the transition from the chain-mail of the thirteenth to the full plate armour of the fifteenth century.

There is much overlapping of styles, when dates are considered, and the subject can only be studied exhaustively from the specialised literature of armour, for which, see Appendix.

Fig. 226 dates 1327, and is from the brass of Sir John D'Auberon (the younger), Stoke D'Auberon, Surrey. His headpiece is a "bascinet." Taking the place of the mail coif is the "camail" or mail tippet, which is fastened to the edge of the bascinet.

His arm defences show circular plates or "palettes," which guard the inside of the arm at pit and elbow. "Coudes" or elbow-cops defend the outside of elbows. The upper arm is protected by half or "demi-brassarts" or "rerebraces." The lower arm has a complete "vambrace" which shows under the rather short sleeves of the mail hauberk. The leg defences include "knee-cops" or "genuillières," probably of *cuir bouilli* (boiled leather). The shins are protected by "greaves" or "jambarts." The upper surface of the foot is covered by five laminated plates or "sollerets" worn over the mail chausses which cover feet and legs. The outermost body-garment is the "cyclas," which came into wear at this period and was a development

of the surcoat; it fits more tightly than the latter, is laced up the sides and is shorter in front. Under the cyclas we can see the "gambeson," a gamboused or quilted garment called in later times the gipon. This gambeson was not always worn, we see other examples of the period which have the cyclas or surcoat worn directly over the mail hauberk. Below the hauberk is worn the gamboused "hacketon" or "hauketon." Sir John wears "prick" spurs, though at this time "rowel" spurs were in use. The description of his shield of arms is "Azure, a chevron, or."

The next example in the period is Fig. 168 on p. 100. This drawing is a rendering in outline of the elaborately decorated miniature of Sir Geoffrey Luttrell (Luttrell Psalter, British Museum MS. 42130, English, about 1340). The decorations are illustrated and described in Chapter XI., pp. 136-137. He is receiving his gilt helm from his wife and his shield from his daughter-in-law. He wears a gilt bascinet without visor and silver chain-mail hauberk. There are circular plates on his elbows, and he has plate gauntlets, also knee-cops and greaves on the front of the shin.



Fig. 226.

His spurs are of the rowelled type. His large square ailettes, his surcoat, the fan-crest of his helm, the pennon of his lance, the trapper and fan-crest of his horse, the cantle and arcon of his saddle together with his shield all bear the Luttrell arms, "Azure, a bend, between martlets argent." As a representation of armour, this picture does not, from its small size, give the constructive detail which is seen on memorial brasses and effigies. On the other hand, the heraldic decoration and the delicate arabesques and diaperings which cover the entire surface of this illumination, and which are illustrated in part on Figs. 246 and 250, p. 137, give it a rare beauty and interest.

Fig. 206, p. 112, illustrates the later type of fourteenth-century armour, where chain-mail has almost disappeared and plate-armour has taken its place. This memorial brass is that of Sir John Harsyck, South Acre, Norfolk, and the date is 1384. It will be noticed that in this new style of armour which characterises the second half of the fourteenth century, the "hauberk of mail" has shortened to the proportions of a vest, and only shows at the armpits and under the lower edge of the jupon—a tight tunic, usually without sleeves—which has taken the place of the linen surcoat and cyclas. The jupon is generally scalloped or ornamented at the lower edge and, as a rule, laced down the back. Between the mail hauberk and the jupon a cuirass of steel was worn, though hidden from view. The bascinet was sharply pointed, and the method by which it was laced to the camail is clearly indicated (for detailed description of this lacing, see Figs. 228*a* and 228*c*, p. 127). The arms and legs are completely encased in plate armour. The broad belt or bawdric is worn straight across the hips, with the sword attached to it on the left side. On the right side

there was usually worn the dagger or "misericorde," though it does not occur on the figure of Sir John Harsyck. The names of the various parts of the plate-armour which have not been already given are as follows: Pieces covering the shoulders, "épaulières"; pieces covering the thighs, "cuissarts" or "cuissards"; pieces covering the leg below the knee, "jambes of plate" or "jambarts"; elbow guards are called "coudières."



Fig. 227.

The heraldic coat of arms of Sir John Harsyck, shown on his jupon, are "Or, a chief sable, indented of four points."

Fig. 227 is from a French late fourteenth-century MS. in the British Museum (Add. MS. 23145). It represents St. Maurice clad in armour, which is similar to that of Sir John Harsyck, but it differs in the visored bascinet, which indicates the close of the fourteenth century. The visor was usually omitted in effigies and memorial brasses, as with it the face of the deceased would not have been visible, but here in the manuscript the type of headpiece illustrated is that which has been called "the pig-faced bascinet." The visors were at first hinged to the bascinet in the centre, but the later varieties, such as that of St. Maurice, were adjusted with a pivot on each side.

Fig. 228*a*, *b* and *c* are details from the effigy of the Black

Prince (who died in 1376) from Canterbury Cathedral. Fig. 228*a* shows the head of the prince with a pointed bascinet surrounded by a rich coronet, the detail of which is shown to a larger scale at Fig. 228*b*. The lacing of the camail to the bascinet is indicated with great clearness. The camail had attached to its upper edge, plates, or a leather binding, pierced with holes, through which passed staples which were fixed on the edge of the bascinet; a cord or thong of leather was then threaded through the staples. This kept the camail and bascinet closely bound together. Fig. 228*c* shows the lacing to a larger scale.

Figs. 229*a* and *b* show the upper and lower parts of the scabbard of the prince's sword. The decoration consists of an engraved pattern enriched with embossed metal and insets of dark-blue enamel. This decoration also displays the favourite and characteristic architectural ornament of the fourteenth century with its pinnacles and crockets.

Fig. 230 represents a portion of the prince's sword-belt with its clasp. It consists of insets of lions' heads with dark-blue enamel backgrounds, the clasp showing a complete lion. The whole suit of armour worn by the Black Prince is of similar character to that of Sir John Harsyck.

Figs. 231*a* and *b* are from the belt and scabbard of Humphrey de Bohun, Earl of Hereford (died 1321) from Hereford Cathedral. Here we have a leather belt decorated with embossed metal and passing through a metal slide or buckle. The decoration from the tip of scabbard harmonises well with that of the belt.

Fig. 232 is again from the effigy of the Black Prince. It clearly shows the method of attaching the rowelled spur to the foot.

Fig. 233 is a pierced leather shoe with quatrefoil archi-

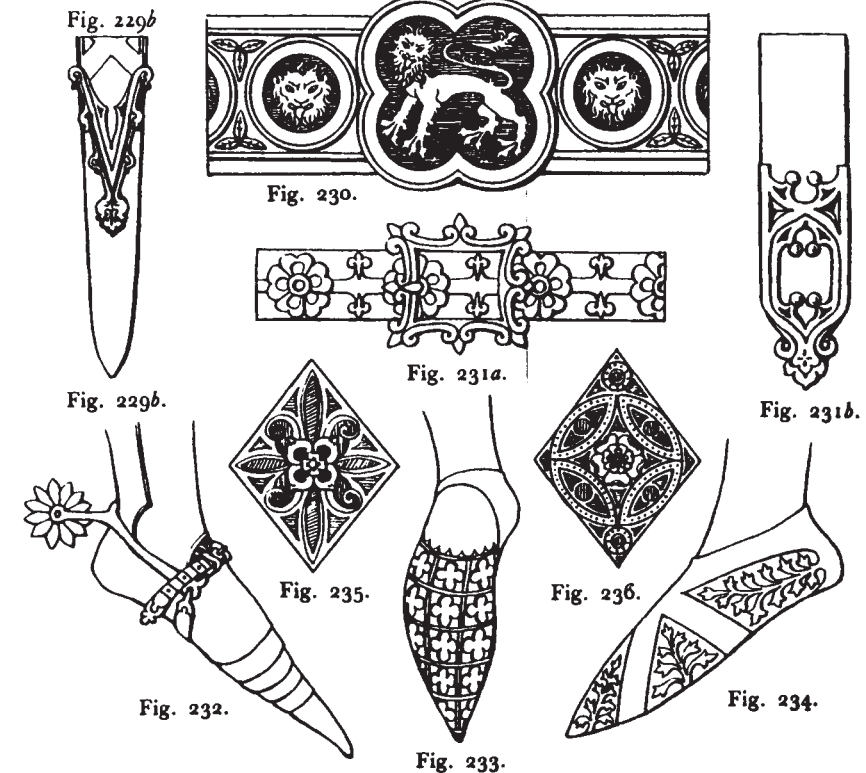
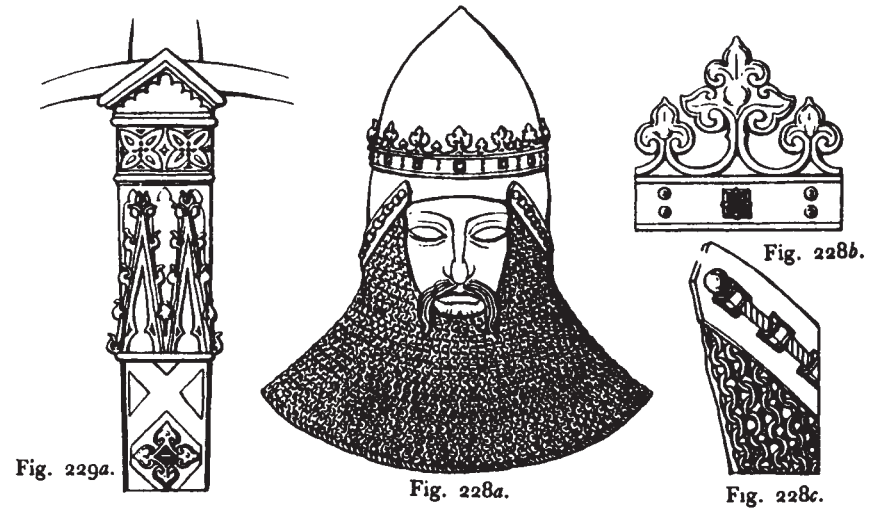

tectural ornament from St. Stephen's Chapel, Westminster (A.D. 1356). Compare with those taken from the same painting, Fig. 188, where the shoes resemble rose-windows in a cathedral.

Fig. 234 is an enlarged view of Fig. 153 (as seen from the side), one of the shoes of Edward III., from his effigy in Westminster Abbey.

Figs. 235 and 236 are from a pastoral staff or crosier, French, fourteenth century. They are executed in translucent enamels and form, in alternate diamond-shaped compartments, a pattern round the upper part of the shaft of the crosier. The central rosettes are embossed. The original is in the Victoria and Albert Museum, Nos. 7951-62.

With the fourteenth-century severity of taste and logical exactness of work diminish, though even as late as the fifteenth century considerable purity of style remains, and to a certain extent there is a gain in depth of sentiment. This applies, however, only to ornament in relief such as has been illustrated in this chapter. The history of ornament in the textiles of this and other centuries follows a path of its own.

CHAPTER XI

FOURTEENTH-CENTURY ORNAMENT CHIEFLY CONSIDERED AS APPLIED TO WOVEN MATERIALS AND EMBROIDERIES

WE may roughly divide the ornamental styles of the fourteenth century into Geometric, Naturalistic and Heraldic.

Examples of Geometric and Heraldic ornament have been given on previous pages applied to the several costumes and Figs. 140 and 141 on page 82 illustrate fourteenth-century Naturalistic detail, though in this case not applied to costume; both these examples are of similar type to those used in woven and embroidered patterns. Fig. 140, a spray of oak, is a "quarry" from a late fourteenth-century stained-glass window, and Fig. 141, a spray of rose, is an incised pattern from a tomb in the Abbey of St. Geneviève at Poitiers—date about 1350. While the textiles of the fourteenth century retain many of the patterns of the late thirteenth century and are of similar free arrangement to the style shown at Fig. 119, p. 67, there is an essentially fourteenth-century type characterised by delicately-designed foliage springing from spiral curves, and often interspersed with birds and animals. The foliage of these patterns is frequently from the vine, the leaves and grapes treated with great lightness yet full of vigour. These designs are usually considered to be of North Italian origin and woven at Lucca.

Fig. 237, with its beautifully-treated vine, scroll-work, and birds and small animals inset, well illustrates the style.

There is a similar pattern in the Victoria and Albert Museum (No. 771 of 1893), but here the main curves of the



Fig. 237.

pattern, instead of reversing as in Fig. 237, all turn in one direction. The colouring of this silk in the Victoria and Albert Museum is as follows : ground, red ; pattern, gold colour ; birds and small animals, green, white and purple.

Fig. 238 has, instead of the vine, lightly-treated oak foliage. This is the design which William Morris has described as "Ladies watering their hounds at woodland fountains." Its place of origin is probably the same as Fig. 237. A fragment of this silk design still exists in the Museum of St. Gall at Buda-Pesth.

Both these silk patterns may be classified as being of the Naturalistic style of the fourteenth century and they should be compared with the pattern indicated on the sleeves and skirt of Letitia Braunche, Fig. 190, p. 107. The size of the detail compared with the human figure can be judged when we realise that Figs. 237 and 238 would be similar in scale to the pattern in Fig. 190, or, if larger, very slightly so.

EMBROIDERY PATTERNS

The designs illustrated in this chapter are none of them ecclesiastical embroidery which, at this period, consisted very largely of embroidered figure-subjects, though the delicate vine scroll-work, already illustrated in the textile, Fig. 237, was also an inspiration for the decoration of church vestments in embroidery.

Figs. 239 and 244 are taken from the effigies of Richard II. and his queen, Anne of Bohemia, Westminster Abbey, clad in parliament robes.

The effigies themselves have been already illustrated in outline, Figs. 211 and 212, p. 115.

The patterns are delicately incised and an idea of their

scale can be got if we note that in Fig. 240 one of the vesica-shaped panels of the design is about eight inches high, full scale; all the other patterns are drawn in proportion to this one.

In actual wear these patterns would have been executed in embroidery and they are chiefly of the heraldic class of fourteenth-century patterns and are, of course, not to be thought of as mere ornament; they have a meaning in spite of their highly-decorative effect.

The study of the science and art of heraldry is essential for any real understanding of medieval ornament and this study is, in itself, a pursuit so fascinating that even a slight acquaintance with the subject will whet the appetite for more knowledge. Fortunately there are numbers of excellent books on the heraldic art, many of them small and inexpensive. The larger volumes will be found in reference libraries. A list of works on heraldry is given in the Bibliography, p. 227.

The heraldic patterns on the robes of Richard II. and Anne are not coats of arms but heraldic badges pertaining to the King and Queen respectively.

Fig. 239 is from the cloak of the Queen, which has a scroll-work border of abstract foliage; the pattern all over the cloak is composed of Anne's initial A and the letter R, standing for Regina or Richard, both letters crowned, and interspersed are small sprays of the same foliage as is found in the border.

Fig. 243 is from the Queen's bodice which has a row of jewels down the centre, possibly indicating buttons, though they may be only of a decorative character, in which case the bodice would be laced down the back.

The decoration consists of a wide border of geometric character and an all-over pattern again consisting of the



Fig. 238.

letters A and R which are crowned and interspersed with a design of conventional foliage.

Fig. 242 is from the Queen's skirt which has the appearance of being gathered or pleated on to the bodice at the hips. The all-over pattern on the skirt is an alternating one composed of two family badges pertaining to Anne of Bohemia, namely, one a knot, the other an ostrich gorged with a ducal coronet, chained, and with a passion-nail in its beak. The letters A R again occur in the pattern both together under a crown.

Fig. 240 (in which, as has been said, the repeats are about eight inches long and which will thus give the actual scale for all the other patterns on this page) is from the King's cloak. In the ornamental border is introduced the Plantagenet badge of the pods of "genista," or broom-plant. The all-over pattern consists of panels surrounded by foliage resembling the genista. In the larger panel we find the King's badge (which he bore in right of his mother who was daughter and heiress of Thomas of Woodstock, Earl of Kent), namely, a white hart lodged, ducally gorged and chained, or. The alternating badge is a sunburst.

The King's robe at Fig. 244 shows three badges pertaining to the King—the hart, the sunburst, and a spray of genista. Fig. 241 is the hem of the robe.

Two examples of heraldic design are shown at Figs. 246 and 250, two shields of arms, both for Luttrell (azure, a bend between six martlets argent), but the decoration on the field or background is, in the case of Fig. 246, a scroll-work of delicate flowers and foliage and this is adapted from the "horse trapper" of Sir Geoffry Luttrell, where plenty of space gives scope for the design, whereas Fig. 250 is from the actual shield carried by the daughter-in-law of Sir Geoffry



Fig. 239.



Fig. 242.

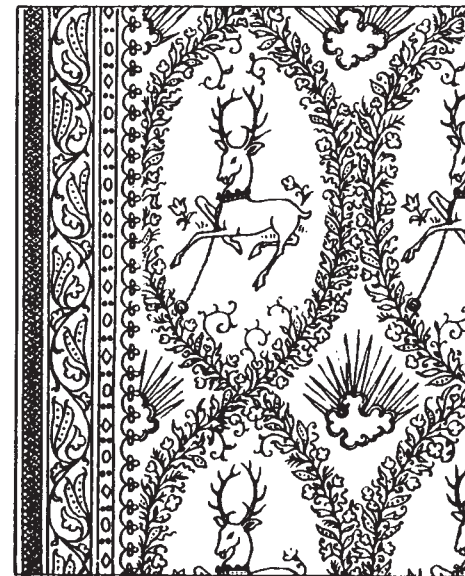

Fig. 240.

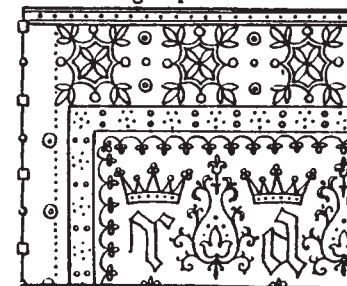

Fig. 243.

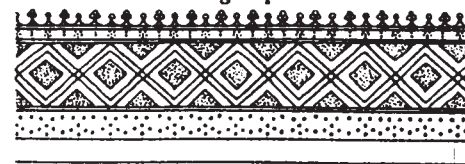

Fig. 241.



Fig. 244.

where the space is much smaller so that the ornament of the background consists of a dainty diapered pattern. The whole page from which these details are taken is shown, in outline, at Fig. 167, p. 100.

Figs. 245, 247, 255 and 256 are all decorative borders from the same Luttrell Psalter (*circa* 1340). It will be seen that they display a great variety and ingenuity, also that, while some are of a geometric type, others verge on the naturalistic.

Figs. 248, 249, 252 and 253 are from the British Museum MS. Roy. 19 Dii, mid-fourteenth century, which manuscript has given the five costumes on page 111.

They might be suitably thought of as designs applicable to embroidered borders on fourteenth-century costumes as might also be the two designs at Figs. 251 and 254, which are from a French MS. in the British Museum (Add. 28162), *circa* 1300. The costumes illustrated on page 97 are, with one exception, from this latter manuscript.

Nothing has been said so far in this volume (dealing, as it does, with costume from the technical standpoint) with regard to contemporary historical and literary references to the subject, but it is almost unnecessary to remind the student that the poet Chaucer, among others, gives a series of most valuable detailed descriptions of the costume of his day. We read of the Knight, the Squire, the Wife of Bath and others, all painted in detail by an artist in words.

In the "Rhyme of Sir Topas" he gives the dress and arms of a knight.

"Of cloth of lake fin and clere
A breche and eke a sherte,
Ful next his sherte an haketon,
And over that an habergeon
For piercing of his herte."

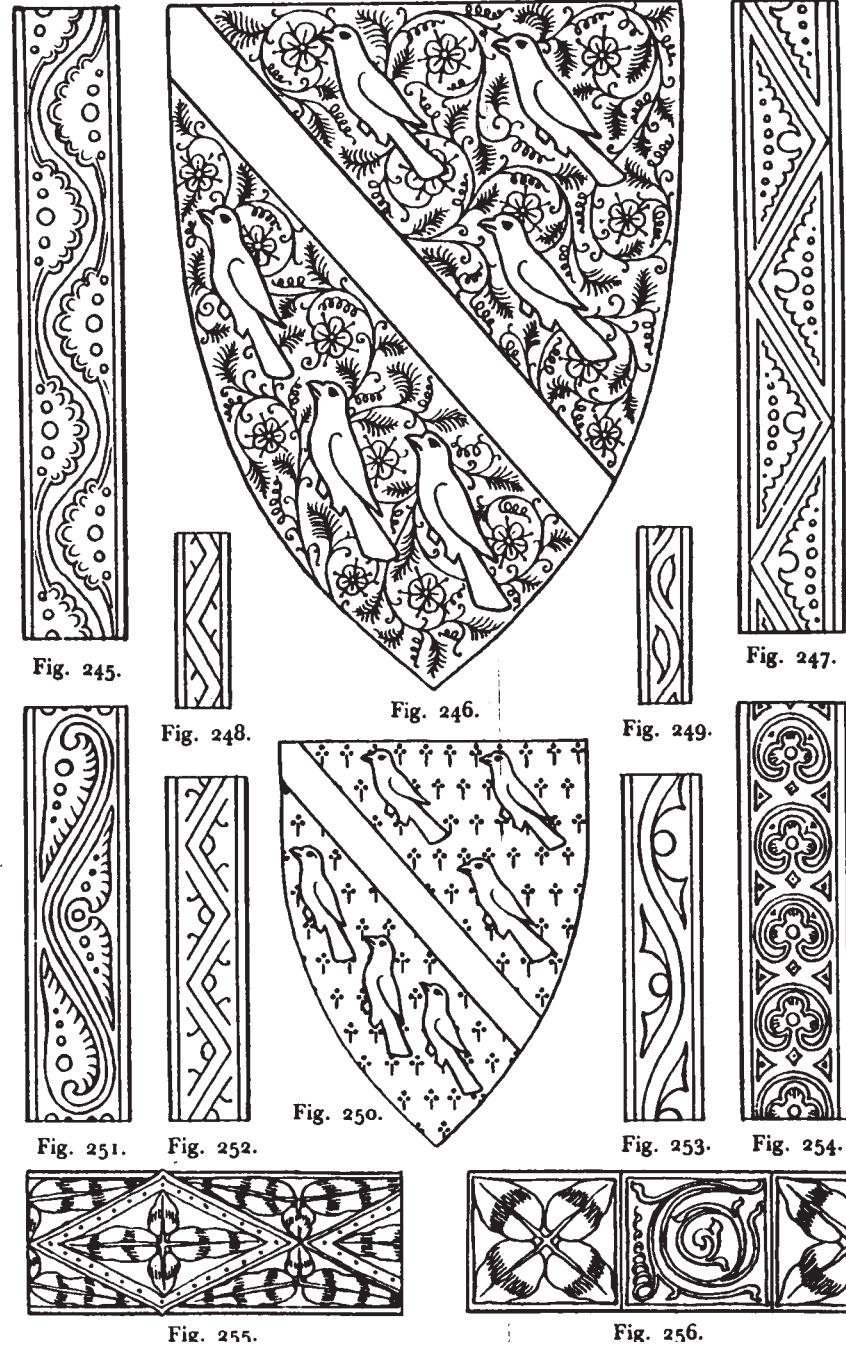

After describing the remaining parts of his armour in detail, Chaucer tells us that "His shield was gilt," and emblazoned with a boar's head and a "charboncle," and his crest was a tower, out of which sprang a lily.

In his poem "The Flowre and the Leaf," referring to the gold nets or cauls which were so much a feature of late fourteenth-century women's hairdressing, he says :

"And everich on her head
A rich fret of golde, which withouten drede
Was full of stately net stones set,
And every lady had a chapelet
On her head of branches fair and green."

Again, in the *Canterbury Tales*, we are told of the Wife of Bath,

"Upon an ambler easily she sat
Y-wimpled well and on hire head a hat
As broad as a bokeler or a targe
A fote mantel about hire hippes large,
And on hire feet a paire of sporres sharpe."

There is a portrait in the National Portrait Gallery, London, of the poet himself (who died in 1400). He wears a species of capuchon in grey, a full grey gown with bag-sleeves, like a houppelande but reaching only a little below the knee, and there is no girdle. His shoes and chausses are black. This painting is based on a miniature which his disciple Occleve caused to be painted as the frontispiece of the Occleve manuscript, "De Regimine Principis," which was presented by its author to Henry V., King of England (B.M. MS. Arundel 38). In the picture both figures wear the houppelande, the King's dress having bell-shaped sleeves touching the ground, and the whole garment lined with ermine, also he has a jewelled belt. The kneeling poet has a houppelande with bag-sleeves.

CHAPTER XII

THE STYLE AND CONSTRUCTION OF FIFTEENTH-CENTURY COSTUME

THE STYLE

As the centuries progress through the Medieval Period change of fashion becomes more rapid. In the thirteenth century the style varies but slightly throughout a hundred years, while in the fourteenth we have noted three distinctly different types. In the fifteenth century we are confronted with change and variation which almost defy description. While it is important for the student of costume to get a clear view of the general characteristics of the styles, and for that reason some broad main divisions must be recognised, we must always qualify any attempted classification with the recollection that survivals from an earlier age are often present amid the newer fashions and also remember that because of the immense variety of types in vogue at any one period in the fifteenth century, it is almost impossible to include the whole.

Broadly speaking, we can divide the century into four periods. 1. Transitional from the fourteenth century. 2. Early fifteenth century. 3. Late fifteenth century. 4. Transitional, towards the sixteenth century.

Again, owing to their elaborate nature, it will be best to discuss characteristics of these four styles in connection with their accompanying illustrations and this may also be said to apply to the styles of hairdressing and headgear.

THE CONSTRUCTION OF COSTUME

While the silhouette and general appearance of the houppelande so enormously popular in the early fifteenth century gives an impression entirely different from that of the full-length tunics of the thirteenth century, the construction was not, at first, at all dissimilar. If we widen the skirt by inset gussets as in the Alb, also widen the sleeves towards the wrists so that they almost reach the ground, we produce, by the addition of a collar, an early type of houppelande developed from a thirteenth-century T-shaped tunic. The cutting out of the tightly fitting gowns of the women of the earliest period, i.e. transitional from the fourteenth century, has been already explained in Chapter VII., but there is one very interesting development in structure caused, as in the fourteenth century, by an attempt to fit the figure tightly. It survives (in women's dress, at all events) until almost the advent of the sixteenth century. There is a picture of the Flemish school, "The Deposition from the Cross," by Gerard David (1460-1523), in the National Gallery, London, which clearly indicates the method of cutting about to be described, and though the gown in the picture has no seam at the waist, the armhole is cut in similar fashion to that shown in Figs. 257 and 258 (see page 142), the latter drawing being taken from the British Museum MS. No. D. IX. (late fifteenth century).

In Fig. 257a we have the seven pieces which form one half of the bodice, A being centre front and B centre back. F, G, D, E, C₁ and C₂ are joined together to form the armhole, which is arch-shaped, as shown at 257d; 257b shows the sleeve pattern with points H, C₃ and C₄. Fig. 257c is a double drawing of the top part of the sleeve

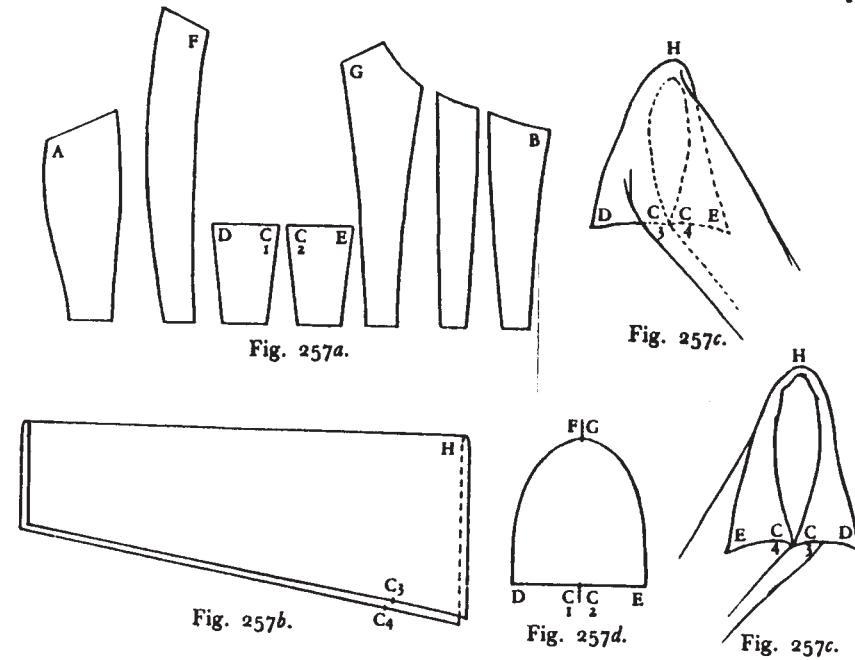

giving back and front view in position ready for insertion into the armhole.

Apart from this example and the various survivals from the earlier centuries, the modern system of cutting and fitting may be said to have commenced in the fifteenth century. The sleeves begin to exhibit the curved top and the armhole suggests the approximately circular form now in vogue. The seams of the garments, when tightly fitting, vary in type, but these types are easily followed from the drawings of figures wearing them. The separation of bodice and skirt in the dress of the women is a feature of the latter half of the century. We also see the introduction of padded garments, and thus artificial effects such as the extreme widening of the shoulders in the men's dress of the later periods. While the dagging or snipping of the edges of



Fig. 258.

While all these innovations characterise the dress of the laity, we find little alteration in ecclesiastical costume, to the study of which we may now proceed, together with a note upon the traditional Coronation Vestments of the English kings.

sleeves, etc., which was such a marked feature of late fourteenth-century dress, disappears towards the middle of the next hundred years, in its stead we have the introduction of much gathering and pleating. The pleats or gathers often appear to be secured in position by being sewn down to a lining or foundation and are then of the type known in present-day language as "cartridge" pleats.

In men's costume the hose or chausses, no longer tied separately to a waistbelt, are transformed by being joined together at the top by two shaped gussets—one in front and one behind. In fact, they have become what we now call "a pair of tights." The method of attaching them with "points" to the short "inner" jacket or "pourpoint" is illustrated at Fig. 316.

While all these innovations characterise the dress of the laity, we find little alteration in ecclesiastical costume, to the study of which we may now proceed, together with a note upon the traditional Coronation Vestments of the English kings.

CHAPTER XIII

REGAL, ECCLESIASTICAL AND ACADEMIC
COSTUME

REGAL COSTUME

THE regal costumes of this century are illustrated each in the period to which it belongs. In the chapter on ornament will be found the crown and other ornamental details from the effigy of Henry IV., King of England, from Canterbury Cathedral. This effigy, in Coronation Robes, shows much similarity with the Royal Coronation Dress of the thirteenth and fourteenth centuries, while the other figures illustrated in royal dress of the fifteenth century are clad, as for ordinary occasions, in a modified version of the fashions of their day.

The table of reigning monarchs and their queens consorts (whose influence was so frequently the cause of the introduction of foreign styles to the court of the country of their adoption) in England, France and Germany is here inserted for reference, but before attempting to classify the century's costume by the reigns of kings, it is in every way desirable to get the larger view of the period from 1400 to 1500. It must also be re-emphasised that a medieval illustrator drew his historic figures of kings and nobles in the costume of his own day with little or no reference to the past. We find, for example, a portrait of King John (1199-1216) clad in late fifteenth-century dress to the last detail, drawn by an artist of this later period. On the other hand, the effigies such as that of Henry IV., and those previously illustrated

144 MEDIEVAL COSTUME IN ENGLAND AND FRANCE

may be considered to be a fair representation, or at all events belonging to a period only a few years later than the death of the person represented.

REIGNING MONARCHS IN ENGLAND, FRANCE AND GERMANY THROUGHOUT THE CENTURY

<i>England.</i>	<i>France.</i>	<i>Germany.</i>
HENRY IV., 1399-1413. <i>m.</i> Joan of Navarre.	CHARLES VI., 1380-1422. <i>m.</i> Isabel of Bavaria.	RUPERT, Count Palatine of the Rhine, 1400-1410.
HENRY V., 1413-1422. <i>m.</i> Katherine of France.	CHARLES VII., 1422-1461. <i>m.</i> Marie of Anjou.	JOBST, Margrave of Moravia, 1410.
HENRY VI., 1422-1461. <i>m.</i> Margaret of Anjou.	LOUIS XI., 1461-1483. <i>m.</i> 1. Margaret of Scotland. 2. Charlotte of Savoy.	SIGMUND, King of Hungary, 1410-1437. <i>m.</i> Marie of Hungary.
EDWARD IV., 1461-1483. <i>m.</i> Elizabeth Woodville.	Regency of ANNE, d. of Louis XI., 1483-1491.	ALBERT II. OF AUSTRIA, 1438-1439. <i>m.</i> 1. Elizabeth, d. of Sigmund. 2. Beatrix of Nuremberg.
EDWARD V., 1483.	CHARLES VIII., 1491-1498. <i>m.</i> Anne of Brittany.	<i>Interregnum.</i>
RICHARD III., 1483-1485. <i>m.</i> Anne of Warwick.	LOUIS XII., 1498-1515. <i>m.</i> 1. Joan, d. of Louis XI. 2. Anne of Brittany. 3. Mary of England.	FREDERICK III., 1410-1493. <i>m.</i> Eleanor of Portugal.
HENRY VII., 1485-1509. <i>m.</i> Elizabeth of York.		MAXIMILIAN I., 1493-1518. <i>m.</i> Mary of Burgundy.

ECCLESIASTICAL COSTUME

While the shapes of the Eucharistic Vestments had long been fixed previous to the fifteenth century, there began to be a modification at this period in the shape of the chasuble, which eventually resulted in a markedly different form for this vestment, namely, that which has sometimes been called the "fiddleback" chasuble.

Fig. 259, which shows a stage in this transition, is a



PLATE VII. COURT COSTUMES: LATE FIFTEENTH CENTURY

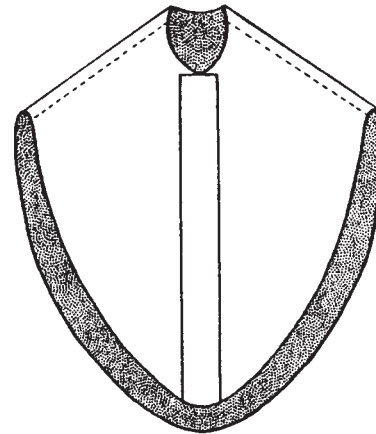

Fig. 259.

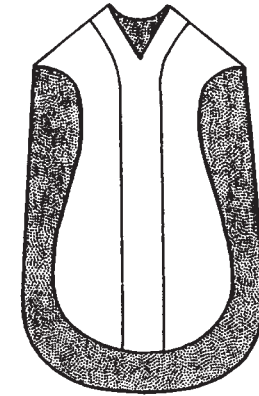

Fig. 260.

measured drawing from a chasuble in the Victoria and Albert Museum (the label reads : " No. 8704 of 1863, German, late fifteenth century "). The material is lined but not stiffened, the extreme measurements are 52 inches long by 45 inches wide. Fig. 261 has been chosen to illustrate a similar garment in wear, though 261 seems a little longer than 259. Fig. 260 is a measured drawing of another chasuble in the Victoria and Albert Museum (the label reads : " No. 696 of 1902, English, late fifteenth or early sixteenth century "). The material is stiffened somewhat, and the extreme measurements are 48 inches long by 30 inches wide. The back view of this chasuble is given in the chapter on fifteenth-century ornament, Fig. 345, p. 210. This cutting out at the sides which is seen in Fig. 260 is said to be due to the fact that the vestment was stiffened, and if the old shape had been retained the arms of the wearer in a stiff garment of such dimensions would have had no freedom of action.

The dalmatic shows no such extreme change as that

which has been described in the chasuble. It certainly became stiffer and the slitting up at the sides was often continued right through to the hem of the sleeve, the garment being fastened at each side with loops and buttons or tied with cords. Measurements of a fifteenth-century dalmatic in the Victoria and Albert Museum (labelled "T. 49 of 1924, English late fifteenth century") show it to be slightly shorter and narrower than the thirteenth-century example given on Fig. 35, p. 25.

Fig. 261 is that of St. Hubert in the dress of a bishop from a painting in the National Gallery, London; (the label reads, "Ascribed to Meister von Werden—Saints—German, 2nd half of the fifteenth century"). The saint is wearing a gold chasuble, an alb and an amice. The foliations on the crook of his pastoral staff, or crosier, have the flame-like quality noticeable in later medieval architectural ornament. From beneath the upper portion of the staff there hangs the "vexillum," or flag, emblematic of the first Christian standard, the "labarum," which was carried before the Emperor Constantine.

St. Hubert's mitre is high and curved in its outlines as was usual in the mitres of this period.

Fig. 262 is from a British Museum manuscript (Roy. 15 E. IV.); it is Flemish and dates about 1470–80. Here we have a fifteenth-century Pope receiving a messenger. The Pope wears his tiara or triple crown. This tiara has taken various shapes since the ninth century. In Fig. 262 it is a peaked head-covering like a tall closed mitre round which are three open crowns placed one above the other. Though they cannot here be seen, it is probable that the two bands, or "infulæ," which are attached to a bishop's mitre, also hang down from the back of the tiara. This triple crown is



Fig. 261.



Fig. 262.

never worn at liturgical functions; it is a symbol of sovereign power (the *liturgical* head-dress of the Pope is the mitre). Before the ninth century the tiara had no crowns; it was a simple helmet-shaped cap of white material. In the twelfth century it had one circlet which became a crown in the thirteenth; in the fourteenth century a second, and later, a third crown was added, such as we find in the effigy of Pope Benedict XII. who died in 1342. The cope in Fig. 262 is apparently made of silk damask or brocade and the Chinese-looking bird upon it was a frequent inspiration to the Sicilian and Italian textile designers as early as the late thirteenth century. In the manuscript the ground-colour of this cope is blue.

The detail on the embroidered orphrey and hood of this cope are so vaguely sketched in the small drawing of the original manuscript that the detail shown in Fig. 262 is merely an attempted reconstruction. It will be noticed that the hood of the cope is attached to the upper edge of the orphrey, also that it seems to hang loosely down the back of the vestment because folds can be seen formed in the silk coming from underneath it. Two Italian copes in the Victoria and Albert Museum of the same late fifteenth-century date as this drawing show the hood in different positions ; in one case it is attached to the upper edge of the orphrey as in Fig. 262, in the other case it is attached to the lower edge of the orphrey. One of these copes (No. 79 of 1864) gives measurements larger than that of the thirteenth-century Syon cope, Fig. 13, p. 10, the straight edge of the fifteenth-century example being 134 inches long and the depth exactly half this measurement. The orphrey is $8\frac{1}{2}$ inches wide and the hood is 9 inches wide by 18 inches in depth.

The figure of the messenger in Fig. 262 is noteworthy for its illustration of spurred riding-boots, also of a parti-coloured hat which is half green, half red. The inner tunic, which shows at the back of the neck, is black, as are the boots. The outer tunic, with its gathered sleeves, is green and red parti-colour to match the hat ; the hose or chausses (now joined together at the top and attached by laces to the inner tunic, not as formerly, separately attached to a waist-belt) are grey. The extreme shortness of the tunic, which is now called the "paltock," is said to be a fashion of German origin by some authorities, while others hold that it came to France from Italy about 1540.

NON-EUCHARISTIC VESTMENTS

The Cope, in its most richly-decorated form and cut out on semi-circular plan, is the foremost of all the non-Eucharistic Vestments ; it may be said to be the chief among the Processional Vestments. It has already been fully described in Chapter III. In Chapter VIII., at Fig. 155, Nicholas of Louth, Rector, 1383, there is illustrated : 1. The *Cappa Nigra* or Black Choral Cope. 2. The Almuce. 3. The Surplice. 4. The Cassock.

1. *The Cappa Nigra* is not stiffened ; its cut approaches the circular, not the semi-circular, shape of the Processional Cope. A hood is often attached to it and in front the lower corners of the garment are sometimes rounded off. Fig. 41, Chapter III., shows a thirteenth-century hooded example. That of Nicholas of Louth, Fig. 155, has no hood, that which appears at the neck being the top of the almuce.

2. *Almucium* or *Almuce*.—This was a large cape, often with hood attached, of cloth turned down over the shoulders and lined with fur. Doctors of Divinity and canons wore it lined with grey fur, and others dark-brown fur. The cape was edged with little fur tails, and two long lappets hung down in front about as far as the knee.

3. *The Super-pellicum* or *Surplice*, an ample garment of white linen with wide full sleeves (see again Fig. 155). The great width of this garment is said to be due to its originally being intended to be worn over a fur-lined cassock (the Latin word *pellicum* indicating a fur lining). The original width of the sleeve was probably only sufficient to go over the fur-lined under-garment, but in the fourteenth and fifteenth centuries the sleeves became very wide, at times they reached almost to the ground like those of the houpe-

lande. The method of cutting the surplice was derived from the alb. There is no girdle worn over the surplice.

4. *The Sub-tunica or Cassock.*—This garment was simply a long coat reaching almost to the ground and fastened up the front. It had fairly tight sleeves. It was worn by men, both lay and clerical, during the fourteenth and fifteenth centuries. As has been said it was often fur-lined and its main purpose was to keep the wearer warm. It is worn under the eucharistic vestments but is completely covered by the alb so that it does not show. Eventually, while laymen changed the fashion of their dress, the cassock was retained by the clergy and may be said to have been their everyday wear.

COSTUME OF THE RELIGIOUS ORDERS

Before describing certain examples of fifteenth-century representations of the costumes of the Religious, it will be of interest to note Fig. 263, which represents a cardinal. It is taken from the well-known British Museum manuscript of "Froissart's Chronicle," No. Harl. 4379-80. As pictured in the manuscript this cardinal is engaged with a fellow cardinal in the coronation of Pope Boniface IX. His robe is of similar shape to the *pallium* of academic dress (see Fig. 267), it is red in colour, as is also his hood and hat. The hood is lined with white fur. The cassock-like garment he wears underneath this red robe has been painted black in the manuscript.

It will be seen that this costume has all the simplicity of the thirteenth century in its softly flowing draperies. There is no suggestion of the stiffness and exaggeration characteristic of contemporary lay costume in this dignified figure.



Fig. 264.

Fig. 263.

Fig. 265.

The same simplicity and dignity survives in the costume of the Religious Orders of this period. Fig. 264 is from a manuscript in the Victoria and Albert Museum, No. A. L. 2087 of 1903. The label of the volume reads: "Carmelite Grail, Sanctorale, of Italian character, for use in Sicily, fifteenth century." The figure of the Carmelite monk here represented wears a white hood and cloak, while the gown underneath is brown.

Fig. 265 is also from a Victoria and Albert Museum manuscript, No. D. 86 of 1892. The label reads: "From a choirbook of the Abbey of SS. Ulrich and Afra at Augsburg, 1494-5, German." Here we have the figure of the Abbot of this German Benedictine Abbey. His hood or cowl is very large and worn low upon the shoulders, forming a

cape or tippet as well as a hood. His wide-sleeved gown has the shape of a surplice and underneath cowl and gown there is a cassock which only shows at the wrists in this picture. The entire habit is black. The crozier has a wooden shaft and a gold or gilded metal top. As has been previously stated it would be impossible in this volume to give a full description of the costumes of the many Religious Orders and again readers are referred to the list of specialist volumes on the subject listed in the Appendix.

In addition to the costumes of the Franciscan and Dominican orders given in Chapter III., also the Carmelite and Benedictine habits illustrated at Figs. 264 and 265, there is Fig. 266 taken from the brass of Abbess Herwy, circa 1525, at Elstow, Bedfordshire. The date is really early sixteenth century, but if this costume be compared with that of Fig. 216 (Alianore de Bohun) in Chapter IX. they will be seen to be almost identical, the habit being that of a widow. The Abbey at Elstow was under the Benedictine rule. The dress consists of a long white gown, a black mantle, a white pleated barbe or wimple, with a head-veil over it. It should here be explained that medieval widow ladies often joined a religious order, taking vows and dedicating themselves to the religious life. This explains the term "vowess." The simple head-veil and wimple of the thirteenth century appears in a portrait of St. Claire in the habit of her order as depicted in the "Sforza Book of Hours," British Museum Manuscript, No. Add. 34294, late fifteenth century, and this type of habit with variations of colour and detail may be said to strike the dominant note for the dress of many of the female Religious Orders.

An interesting variation, however, from the usual type is the dress of the Sisters of St. Vincent de Paul, whose blue

habits and picturesque white head-dresses may often be seen in the streets of the city of Westminster to-day. Though their order dates its foundation from the seventeenth century, the habit is said to be derived from a French (Ile de France) peasant costume of the fifteenth century.



Fig. 266.

ACADEMIC COSTUME

With the fifteenth century comes the first period of distinctly academic dress or habit, that is, when it can be classified with any degree of clearness. It was undoubtedly founded upon ecclesiastical and monastic dress, the schools being frequently held within the precincts of the religious houses. The Benedictines, Dominicans, Franciscans and Carmelites were among the many monastic orders who engaged in teaching, and among these the first and most prominent were the Benedictines.

In medieval times the scholar was regarded as an ecclesiastic in minor orders.

Firstly, as in ecclesiastical costume, it will be best if the principal garments of academic wear be enumerated.

1. *The Pileus or Cap*, the distinctive head-dress of doctors. This cap was round or square. The square shape was made of four different pieces of material joined together and had a small point at the top. It is difficult to imagine that this cap eventually through successive modifications became the "mortar-board" of modern English university wear, but

such is the case. The small point of the original pileus became the modern tassel. It resembles in Fig. 269 a beret.

2. *The Caputium*, which includes (a) the *Hood* and (b) the *Tippet* or *Cape*. The hood was originally worn as a head-covering, but was later dropped back upon the shoulders and underwent several modifications before it arrived at its present-day form. The various colours, materials and linings of the hood were already, in the fifteenth century, being used to denote academic rank and qualifications as in modern times. The short shoulder-cape or tippet was really the lower part of the hood, but at times the upper part or head-covering is cut off and the lower part alone is worn.

3. *The Sub-Tunica* or *Cassock* has been already described in its place among the non-eucharistic ecclesiastical vestments. It was generally worn by all members of the universities under their gowns. The cassock was of scarlet for doctors of divinity and of law.

This garment was the ordinary wear for schoolboys and survives at present in a slightly modified form as the dress of the "Blue-coat Boys" or scholars of Christ's Hospital School, once a familiar sight in the city of London before the school was moved into the country.

4. *The Almuce*, already described as being one of the ecclesiastical vestments, had its place in academic costume, it was distinctive of masters and doctors.

5. *The Taberdum* or *Tabard*.—A garment which has been illustrated as an occasional form of civilian dress in both the thirteenth- and fourteenth-century divisions of this book. It has been noted that the name "Sclavine" was given to it at one time (see pp. 82, 83). It is also shown in wear as part of fifteenth-century academic dress, Fig. 270, p. 155. All bachelors of Trinity Hall, Cambridge, also the Master

and bachelor fellows of Clare Hall and the bachelors of King's Hall, as early as the later fourteenth century, were required to wear the tabard.

6. *The Cappa Clausa* or *Closed Cope*, sewn down the front, except for a short slit which enabled the hands to emerge. It is here illustrated at Fig. 271. Regents in theology, arts and laws lectured in this (seemingly most uncomfortable) garment.

7. *The Pallium* (this garment, which must not be confused with the pallium granted to archbishops by the Pope, see Fig. 5, Chapter III.) appears to be cut upon a circular model like the *cappa clausa*, but it has *two* openings, one at either side for the hands. Regents in theology, arts and laws were permitted to lecture in the pallium as an alternative to the *cappa clausa*. It is illustrated at Fig. 267, below.

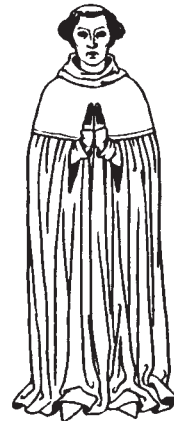

Fig. 267.



Fig. 268.



Fig. 269.



Fig. 270.

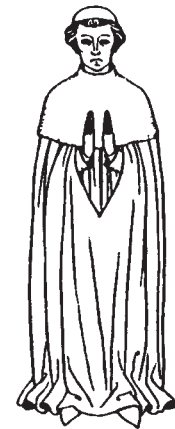

Fig. 271.

8. *The Super-Pellicum* or *Surplice*, previously described in the enumeration of non-Eucharistic vestments, occasionally appears as an academic garment.

There were four classes in the university community—

1. Doctors of Sacred Theology, Canon and Civil Law and Physics.
2. Bachelors of the same Faculties.
3. Masters and Bachelors of Arts.
4. Undergraduates.

It will be seen that out of the five figures given to illustrate academic dress, i.e. Figs. 267–271, three have their heads uncovered and have the tonsure. Clerical dress and the tonsure were imposed in Paris, and in Italy scholars had to wear a long black robe.

It is really with the advent of the sixteenth century that the foundations of modern academic dress in England were set, and therefore the period described and illustrated in this chapter bears little relation to academic dress as we know it to-day.

The illustrations of fifteenth-century academic dress given on p. 155 include Fig. 267, John Bloxham, Bachelor of Divinity, Seventh Warden of Merton College, Oxford; he wears *caputium pallium* and *sub-tunica* or *cassock*.

Fig. 268, John Whytton, Priest; he wears the *caputium* with a very short *cape* or *tippet* and the *sub-tunica*. These two figures are taken from a double memorial brass to their memory at Merton College, Oxford, which was erected about 1420.

Fig. 269 is from the memorial brass to Richard Harward, 1493, Master of St. Cross, Winchester. He wears the square *pileus* or *cap*, the fur *almuce* with tails and lappets, the *super-*

pellicum or *surplice* and the *sub-tunica* or *cassock*, the cuffs of this latter garment show a fur lining.

Fig. 270 is that of William Tabram, 1432, Royston Church, Herts. He wears the *caputium* or *hood* with *tippet* or *cape*, the *taberdum* or *tabard* and the *sub-tunica* or *cassock*.

Fig. 271 is that of Thomas Hylle, 1468, New College Chapel, Oxford. He wears the *round pileus* or *cap*; the *caputium*, but without the *hood*, so that it may be more correctly styled the *tippet* or *cape*, the *cappa clausa* or *closed cope* and the *sub-tunica* or *cassock*.



Fig. 272.

Fig. 273.

LEGAL COSTUME

There are a number of memorial brasses of fifteenth-century date which give a clear indication of legal costume, also miniatures in manuscripts of the period where the subject of the picture is a trial before the judges of the courts. As a rule, the judicial costume of the fifteenth century consisted of a *close cap* or *coif*, such as we are familiar with since the thirteenth century, that *plain gown*, similar to the *cassock*, reaching to the ankles, which was popular for civilian wear from the end of the fourteenth century, a short *fur cape* or

tippet and a full-length *circular* or near circular *mantle* or *cloak* buttoned on the right shoulder, and again of familiar type in the fourteenth century. A hood completed the costume, which often varied in detail but was in the main of the character which has been described. Fig. 272 is from the memorial brass of Sir John Juyn, Chief Justice of the King's Bench, 1439. This example shows the *coif*, *hood*, long *circular mantle*, short *cape* and long *plain gown* in wear. Fig. 273 is that of a notary, with inkhorn and pen-case at his girdle; it is from a brass at St. Mary Tower, Ipswich. He wears the long *plain gown* or *cassock* only. Instead of the *coif* he has the popular civilian turban-shaped hat with its pendent liripipe or scarf (derived, as will be explained in a further chapter, from the fourteenth-century capuchon or hood). Another example of legal costume, not here illustrated, is that of John Rede, serjeant-at-law, from his brass, dating 1404, at Checkendon, Oxfordshire. He is dressed in a plain, ungirded, fur-lined *cassock* with *hood* attached; his head is uncovered.

CHAPTER XIV

CIVILIAN DRESS OF THE FIFTEENTH CENTURY

PERIOD I. TRANSITIONAL FROM THE PREVIOUS CENTURY

THE sources from which we draw our information for this period and, indeed, for the whole century, are numerous and varied—manuscripts, memorial brasses and stone or metal effigies, tapestries and paintings still exist in profusion to teach us how the fifteenth-century folk were clad.

To search for some of the leading features which mark out the first decade of the century from the periods preceding and following it should be our chief consideration.

(a) Perhaps the most arresting point to begin with is the disappearance of the slim-hipped silhouette which characterised the costumes of both sexes in the mid-fourteenth century period. Persons of fashion in the early fifteenth century wear the girdle high and the women's hips are large.

(b) Next we notice the immense popularity of the *houppelande* worn by both sexes but more frequently by the men; the dagging of the sleeve edges is still a feature, but this soon recedes as the century progresses, and the bag-sleeves which came into fashion very late in the fourteenth century are still very much in vogue.

(c) The great popularity of the turban-shaped head-dress for both sexes, and the fantastic methods of the men in wearing the capuchon or hood which became a highly decorative hat instead of the simple head-covering it originally was. (For illustrations of the capuchon, see next period.)

These points can best be illustrated by reference to our



Fig. 274.

Fig. 275.

illustrations. Figs. 274 and 275 are from the brass of a civilian and his lady, *circa* 1400, Tillbrook Church, Bedfordshire. The man wears his hair and beard after the manner of the late fourteenth century. He is clad, like his wife, in a fur-lined houpelande with bag-sleeves. His hood or capuchon is worn over the houpelande and thrown back off the head. His metal belt or girdle is worn high and his large dagger or anelace, which usually depends from the belt, shows in front. The lady's hair is dressed in two small cauls or nets on either side of the forehead, the nets being connected by a jewelled band similar in character to the late fourteenth-century head-dresses, her head-veil is notched at the edges. These figures may be taken to be characteristic of the well-to-do merchant class of the period.

Figs. 276-280 are from a British Museum MS. (No.



Fig. 276.

Fig. 277.

Fig. 278.

Fig. 279.

Fig. 280.

Roy. 20 CVII.), "Les Chroniques de Saint Denis," early fifteenth century. The women wear the fourteenth-century type of dress (*côte-hardi*) but with full wide skirts. The two ladies (Figs. 276 and 279) show characteristic early fifteenth-century head-dresses. Fig. 276, the turban shape, and Fig. 279, the two nets, beginning to get very much larger than their fore-runners in the fourteenth century. The head-veil also begins to take the characteristic dip in the centre and points at each side to become much more exaggerated later on.

The nurse-maid, Fig. 277, wears the two large side-nets combined with a very stylish capuchon. Her girdle is low

after the fourteenth-century manner, but she is not a fashionable lady.

In Fig. 278 the elderly nurse is faithful to the wimple retained by older women in the fifteenth century, but over it in place of a head-veil she wears the same quaint type of capuchon as the young nurse-maid.

The young man, Fig. 280, wears the turban head-dress and his bag-sleeved tunic takes the lines of a houppelande which has been cut off at the knee. His dagger or anelace hangs from his belt.

Next we have three figures from a set of French tapestries (first half of the fifteenth century) in the Musée des Arts Decoratifs, Paris. The subject of the tapestries is "Scenes of Romance" and the figures in the original seem to be treading the measures of some stately dance against a background of flowery meadows beside a wood. It should here be said that the execution of a piece of tapestry was a task which occupied the weavers a considerable time—perhaps years—hence the costumes depicted may at times be rather earlier in date than that of the completion of the tapestry.

Figs. 281 and 282 both wear types of the turban head-dress, while the lady in Fig. 283 wears the fourteenth-century "crespine" head-dress with a wreath of flowers across her forehead in place of the more usual jewelled band. The love of fur linings and trimmings is noticeable in all three costumes and this was to increase in the next period of fifteenth-century fashion. The man (Fig. 282) wears a high-necked houppelande with long dagged sleeves and slung over one shoulder, a baldric decorated with hanging bells; this fashion, which is also seen in waist belts, is said to have originated in Germany.



Fig. 281.

Fig. 282.

Fig. 283.

PERIOD II. EARLY FIFTEENTH CENTURY

The leading features of the second period of fifteenth-century costume might be described as follows.

(a) The popularity of the *full and voluminous* in draperies continues. Among men's costumes those of the Court and of persons of importance often reach to the ground, and even trail upon it.

(b) The *capuchon* undergoes great changes and except for peasant and other humble folk develops into a sort of hat made up on a foundation as is shown in several of the illustrations to this period.

(c) The dress of both sexes shows great variety in the

shape of the *sleeves*, which begin to be set in after the modern manner.

(d) The women's dress as a rule becomes *much looser*, in fact, it is often a *houppelande* which has been turned into a frock, often cut fairly low at the neck and always with the waist placed very high.

(e) The women's headgear shows great variety and becomes very large, though in variety and size this period is merely a prelude to the period which is to come.

Referring to our illustrations, Figs. 284 to 290 are all taken from *one piece of sculpture*—namely, a decorated chimney-piece at the Dam, Amsterdam. They are said to represent Counts and Countesses of Holland and have been chosen to exhibit the immense variety existing at one time in early fifteenth-century costume.

Fig. 284 has a head-dress developed from the jewelled net of an earlier period with veil thrown over it (compare with Fig. 279). In Fig. 284 the shape has become what has been called the *Heart-shaped Head-dress*. The dress of this figure is cut on the old T-shaped plan as is possibly that of Fig. 287, but all the other costumes on this page have the sleeves set in to the shoulder in modern style.

Figs. 285 and 286 show new and exaggerated forms of the *Turban* type of head-dress. Fig. 287 has a stiffened veil supported by wires underneath, which may be said to be an early example of the *Butterfly Head-dress*.

One of the four men, Fig. 289, here represented wears a species of hat which was popular at this period, not unlike the modern "topper" or "chimney-pot hat," but the other three examples (Figs. 288, 290 and 291) show the changing of the capuchon into a hat. Fig. 290 represents an early stage in this development, the shoulder-cape or lower part



Fig. 284.



Fig. 285.



Fig. 286.



Fig. 287.



Fig. 288.



Fig. 289.



Fig. 290.



Fig. 291.

of the capuchon hangs over towards the right, the crown of the head is thrust into the part which should frame the face, the liripipe which should hang down the back as a long narrow tube has been opened up, snipped along the edge into points, and taken the form of a narrow scarf which hangs out on the left side, is drawn across the chest and thrown over the right shoulder. Fig. 288 has a species of combined turban and capuchon, the latter having dwindled into a piece of drapery which hangs across the turban. Fig. 291 (which is taken from a French early fifteenth-century tapestry) shows also a combination. The turban is in the form of a padded ring, not unlike a small motor-

tyre, while one sees the remnants of a capuchon thrust through it. The shoulder-cape portion is pleated and fans out at the top of the head, while the liripipe, again taking the form of a long scarf, appears from underneath the padded ring and hangs down at the right side.

Fig. 292. The four costumes here represented are characteristic of the Court of France in the early fifteenth century. They are taken from an illustration called "The Month of April" in that renowned manuscript "Très Riches Heures du Duc de Berry." The two figures in front are those of a young gentleman and lady of noble birth who are plighting their troth to one another and exchanging rings. The turban of the youth is decorated with fanciful "dagged" or snipped material which has apparently been stiffened; the shape is derived in part also from the capuchon. His long fur-lined houppeleande trails on the ground and the sleeves are embroidered with a heraldic badge. The fiancée wears a fur turban, with three upstanding feathers. Her dress is derived from the houppeleande but fits the figure tightly as far as the hips. The fur lining and appliqué seem very thin and might almost be velvet. In the background the older man has a fanciful adaptation of the capuchon on his head. He wears an embroidered baldric over one shoulder and his garment only reaches to the calf of the leg. The older lady has a wreath of roses round her jewelled net and underneath the long sleeves of her houppeleande a second pair of sleeves appear with fringed edges and a woven floral pattern of oriental-looking design.

It has been said in the introduction to the fifteenth century that besides its current styles there are various survivals.



Fig. 292.



Fig. 293.
namely, Edward, Baron Charlton of Powis, and Alianore Holland. As a rule the ladies' mantles were charged with either their own arms, impaled with those of their husbands (cf. Lady Luttrell's arms, page 99), or those of their husbands only. It will be seen that this figure wears the tight-fitting gown of the fourteenth century (*côte-hardi*) and over it a late form of the surcote now called

Fig. 293 may be said to be one of them, both in the shape of the garments and in their heraldic decorations characteristic of the fourteenth century. This costume is from the brass of Joice, Lady Tiptoft, Enfield Church, Middlesex, 1446. On her head there is an early form of the *Horned Head-dress*, though her coronet somewhat disguises the hornlike projections of her jewelled net. She wears a heraldic mantle impaling the arms of Powis, dexter side, and Holland, sinister side. The heraldic description is as follows: "For Powis, Or, a lion rampart Gules." "For Holland, Gules, three lions of England within a bordure." These arms charged upon her mantle are derived from the father and mother of the wearer,

the *super-côte-hardi*. This latter garment is trimmed with ermine. The method of fastening the cloak is identical with that seen in thirteenth- and fourteenth-century costumes.

Fig. 294 is taken from a hunting scene illustrated in a French manuscript of the early fifteenth century (British Museum, No. Harley, 4431 fol. 144). The capuchon is twisted and snipped so that its origin is hardly discernible. The fur-lined *houppelande* is short and the edges daggd. The dress could be easily suitable for



Fig. 294.



Fig. 295.



Fig. 296.



Fig. 297.



Fig. 298.

walking. There is another illustration in this manuscript (fol. 81) entitled "a riding party"; in this there are three ladies riding with two men. These costumes are in no wise different from those worn while walking and the ladies are riding side-saddle.

Fig. 295 shows a group of huntsmen listening to the orders of their master; it is taken from a French manuscript of the early fifteenth century entitled "Livre de la Chasse et les Oraisons de Gaston Phébus." It will be noticed that the men wear the fourteenth-century capuchon in a modified form and that all have the bag-sleeve.

Fig. 296 is from a mid-fifteenth-century French manuscript in the British Museum, No. "Add. MS. 35313, F. 45b." It represents a shepherd and his dress is not unlike those of his fellows in the thirteenth and fourteenth centuries. He wears the old form of capuchon with a cape attached, under

this a short circular cloak open at the left side. Both capuchon and cloak are grey. The loose tunic under this is orange; the long hose, or chausses, are cream, as are the gloves; the short hose dark blue and the boots black.

Fig. 297 is from the same manuscript as Fig. 296. It can be compared with the illustration of women spinning in the thirteenth and fourteenth century, see pp. 50 and 102. The very stylistic capuchon and the under-dress are deep red, the over-dress dark blue and the apron white. One sees in this costume the increasing elaboration of the dress of even the working woman in the fifteenth compared with her counterparts in the thirteenth and fourteenth centuries.

Fig. 298, from a British Museum manuscript, No. "Add. 18192, f. 52, Paris, early fifteenth century." Here we have a repetition of the subject—an elderly man sitting in front of the fire—which has already been illustrated in the thirteenth century, page 46. Again one notices increased elaboration in dress as the centuries progress. In Fig. 298 the hat is black, also the shoes, belt and pouch. The capuchon is deep blue, the circular cloak green, and the loose gown is russet. The manuscript picture illustrates a Nativity and in it this elderly man represents St. Joseph.

Figs. 299, 300 and 301 are from the British Museum Manuscript No. "Add. 18850," the well-known "Bedford Book of Hours," French, about 1423. Fig. 299 is a pork-butcher, capuchon red, tunic dark blue, apron white, hose dull pale purple, boots black. Fig. 300 has his hat black, tunic rose, hosen dark blue and boots black. Fig. 301, cap red, tunic dark blue, hose green, boots, belt and pouch black. The seed is carried in a white cloth. These Frenchmen are not clothed very differently from their fellows in England and Germany. There is an interesting German

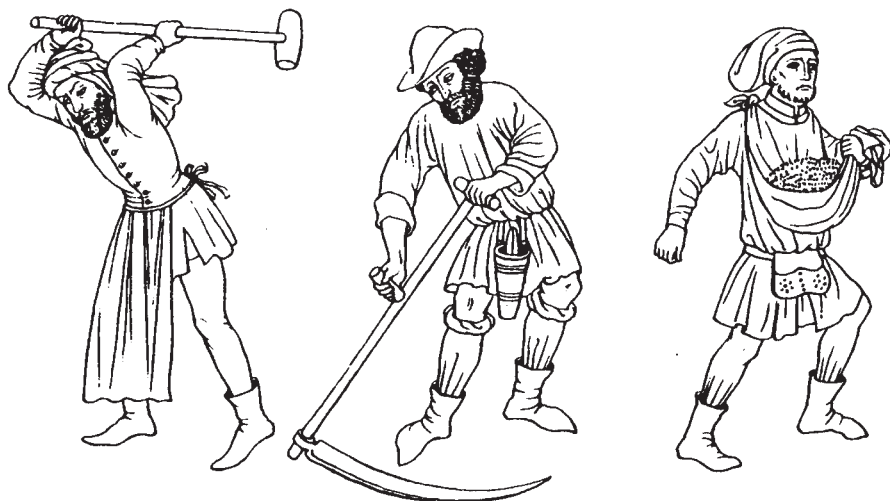

Fig. 299.

Fig. 300.

Fig. 301.

tapestry in the Victoria and Albert Museum, "The Field-labours of the Months," No. 6 of 1867, dating first half of the fifteenth century and illustrating among other rural pursuits the same subjects as Figs. 300 and 301; the costumes differ little from those in the French MS., except that the German sower and scythesman wear more pointed shoes.

The comparison of ladies of fashion (not here illustrated) in two contemporary representations of Flemish and Italian costume of mid-fifteenth-century date again show great similarities. The Italian example is from the well-known "Dini Cassone," an Italian Marriage Coffin of mid-fifteenth-century date, No. 7852 of 1862 in the Victoria and Albert Museum. The Flemish example is from a Flemish tapestry, mid-fifteenth century, in the same Museum, No. 717 of 1904. The Italian and Flemish ladies both wear full high-waisted gowns with bag-shaped or hanging bell-shaped sleeves,

jewelled hair-nets with the covering veil giving the well-known heart-shaped type of head-dress so favoured at this time.

It was in the late fifteenth century that distinct divergence of style began to be evident in the countries of western and southern Europe.

PERIOD III. LATE FIFTEENTH CENTURY

The dress of men and women of fashion from *circa* 1450 till the late decade of the century may be said to be the peak period of the Middle Ages for variety and stylistic exaggeration. It is in men's dress that the styles are most pronounced. In headgear we find the capuchon gradually disappears and its place is taken by an infinite variety of hat shapes. The silhouette of the figure shows immensely broad padded shoulders, slim waist and full-shirted tunic often cut so extremely short that it only reaches at times to a few inches below the



Fig. 302.



Fig. 303.

of early fifteenth-century types. The shoes are very long and pointed, and the hose or chausses are joined together at the top by a gusset back and front to form one complete garment which is attached by small laces tied at intervals to the garment above (see Fig. 316, p. 181).

Fig. 302 is a group of three figures showing two young men greeting a person of distinction. They are from a Flemish manuscript dating *circa* 1468 (the artist is the celebrated Loyset Lyédet). All the features referred to as belonging to this period of men's dress are well shown here.

waist. As has been already remarked the name *jupon* given to the men's tight tunics in mid-fourteenth century has now been changed to *paltock* or *pour point*. Long coats or tunics were also worn, derived from the *houppelande*, but these lost the flowing lines of the latter garment. There is a stiffness in the arrangement of the pleats, also in the inset gathered sleeves which gives an entirely different effect from the soft voluminous draperies

The very short circular cloak fastened on one shoulder is characteristic. The high collars with their wide opening in front are also noteworthy. Fur linings and trimmings were still very popular though perhaps they were not quite so heavy in effect as those of the first half of the century.

Fig. 303, a group of three ladies from a miniature in the manuscript "Statutes and Privileges of Flanders, 1454-67." These costumes may, therefore, be said to be contemporaneous with those of the three men in Fig. 302. Here we get on left and right a front and back view of what is sometimes called the *Forked Head-dress*. It seems to be a development of the heart-shaped type, the two top edges of the latter being drawn closer together and thus producing this new variety—the forked.

The central figure wears what has been called the *Butterfly Head-dress*, already illustrated at Fig. 287. The type shown at Fig. 303 is much more artificial and elaborate in construction than the earlier example. A very striking note appears in the women's dress of this period. *Practically all the variety is in the head-dress*. It will be seen that the three dresses in this illustration are almost identical in type. They differ from the dresses of the earlier period in that they have tight sleeves with fur cuffs and in the front of the bodice the V-shaped necks with small stomacher filling up, and turn-over collars are again identical and we may presume that the two figures in front view have the backs of their bodices cut in the same manner as the third figure which shows the back view.

One point to be noted is the increasing width of the belt, also that there is no doubt at all that these gowns are seamed at the waist and the skirt gathered on to the bodice. The seams of the bodice itself are not indicated in the small



Fig. 304.

Fig. 305.

Fig. 306.

Fig. 307.

drawing in the manuscript but they might possibly be cut after the manner of Fig. 258, p. 142. The skirts of this date are of great length, at times one might almost say they trail on the ground in front almost as much as at the back.

Figs. 304-307 are taken from a manuscript of the fifteenth century in the Bibliothèque Nationale, Paris. These costumes are those of four men of different ages. Figs. 304 and 307, young or middle-aged; Fig. 305, a youth of about sixteen; and Fig. 306, an elderly man. It will be seen that this elderly figure wears a capuchon, but in its fifteenth-century form, where the true construction has disappeared and the liripipe is turned into a scarf. The sleeves of the older man and his long gown also display simplicity and restraint, a quality so markedly absent in the dress of Figs. 304 and 307. The group of four ladies, Figs. 308-311,



Fig. 308.

Fig. 309.

Fig. 310.

Fig. 311.

represents the costumes of women contemporaries of the four male examples at Figs. 304-307. Fig. 308, this lady is taken from a Flemish manuscript in the British Museum (No. 14 E. II Roy., circa 1473-83). Here we see an example of the *Steeple Head-dress* or "*Hennin*." This head-dress is generally considered to have been brought to the French Court by the consort of Charles VI., Anne of Bavaria. After it had become the vogue in France, it was introduced into England.

Fig. 308 is a remarkably simple example, and shows signs of developing into the rather demure hood which was so popular in the fourteenth- or last period of fifteenth-century fashion. The small loop on the lady's forehead calls for notice, this is a portion of a species of cap made of wire netting called the *frontlet*, which passed over the head and

allowed a small loop to appear over the forehead. It was covered with black material, and its purpose was to take the strain and discomfort off the head of the wearer of these tall head-dresses which were not worn upright but lying backwards at more or less of an angle with the forehead. The dress of this figure calls for little comment, the neck opening is pointed both back and front. The colouring is as follows : steeple head-dress, gold turned back with black ; chemisette, black ; fur, white ; belt, blue ; dress, peach colour ; underskirt, brown.



Fig. 312.

Fig. 309 is from a British Museum manuscript (No. Harl. 1473-75), dating about 1475. Here we have another illustration of the *Steeple Head-dress*. The *Frontlet* again shows on the forehead. There is no turn-back to this steeple, but a large double veil is thrown over it, which must add greatly to the strain in wear. The colouring is as follows : gown, rose with grey furs ; belt, grey with gold stars ; head-dress and shoes, black ; veil, white ; underskirt, blue with grey flounce.

Fig. 310 is from a British Museum manuscript (No. Nero. D. IX. Cott.). This illustration shows how the *décolletage* of the bodice of this period was, when desired, filled up with a chemisette, and under the steeple head-dress a species of wimple covers the neck. The skirt is made



Fig. 313.

Fig. 314.

Fig. 315.

into a convenient walking length by means of an extra girdle. The colouring is as follows : veil, white ; head-dress, wimple, chemisette and shoes, black ; dress, rose ; wide belt, blue ; second girdle, black and gold ; fur trimmings, white.

Fig. 311 is from a British Museum manuscript (No. Roy. 15 E. IV., Flemish, circa 1470-80). This lady is wearing the *Horned Head-dress* ; this head-dress surrounds a species of cap which has the appearance of a *truncated steeple*, also underneath the horns there is a veil of what is called the *lampshade type* ; it is stiffened at the edges with wire and fastened into the cap with ornamental pins. The colouring is as follows : cap and horns, black with gold embroidery ;

veil, white ; chemisette within small stand-up collar, black, as are also the fur collar and cuffs ; dress, russet brown.

Fig. 312 is from the brass of Isabelle, wife of William Cheyne, in Blickling Church, Norfolk, dating 1482. Here we have an example of the *Butterfly Head-dress* as it was worn late in the century. Underneath there is a truncated steeple, richly embroidered. The "butterfly" arrangement of the veil covering it is achieved by stiffening and probably wires supporting in addition. The elaborate and heavy necklace is a late fifteenth-century feature, as is also the heart-shaped *décolletage*.

Fig. 313 is from a British Museum manuscript (No. Harl. 1892, f. 68, late fifteenth century). This figure of a jester should be compared with the thirteenth- and fourteenth-century jesters at headpiece and p. 120. It will be seen that the points and bells have increased in number through the centuries. The colouring of Fig. 313 is as follows : hood, white ; tunic, blue ; one leg, green ; the other, red.

Fig. 314 is from that celebrated British Museum manuscript of "Froissart's Chronicle" (No. Harl. 4379 and 4380). This costume is that of a late fifteenth-century French king, and in the same manuscript the peers of both England and France wear practically identical garments, minus the crown. Fig. 314 takes the form of a circular cloak with a long slit at either side to accommodate the arms. While the neck of this figure is merely trimmed with a small band of the fur lining and two ornamental lappets, other similar gowns in this manuscript show a small fur hood or capuchon with the lappets attached to it. The colouring of Fig. 314 is as follows : outer cloak or robe, rose ; inner garment, blue ; shoes, black ; fur, ermine.

Fig. 315 is from a Flemish MS. in the British Museum

(No. Roy. 15 E. IV., circa 1470-80), from which also Figs. 262 and 311 have been illustrated. The present costume is that of a trumpeter wearing in addition to the short *paltock* and *chausses* or hose, a species of parti-coloured *Tabard* with badge on the left side. The colouring is as follows : hat, green and red, parti-coloured ; tabard, green and red, parti-coloured ; *paltock*, yellow ; hose, pink.

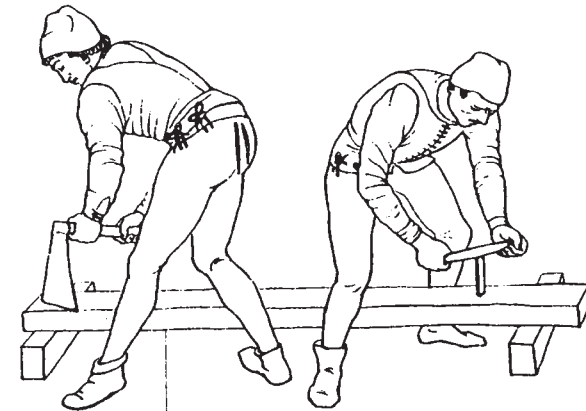

Fig. 316.

Fig. 316. This illustration of two carpenters engaged in squaring and piercing a beam of wood is from the *Book of Hours* of Etienne Chevalier, illustrated by the celebrated artist Jean Fouquet, who was born at Tours about 1415 where his death also took place about 1481. Figs. 316 and 317 were painted probably before 1460. The original is in the Musée de Chantilly and dates circa 1460 (one page is in the Louvre in Paris, see Fig. 317). Fig. 316 shows well the method of attaching the hose to the tunic (now "pourpoint") by means of "points," or laces tipped with "aiguillettes" or metal tags passing through holes at intervals and tying the two together. While it is possible that, in the earlier examples of hose, such as those of the thirteenth century, the leg may have had one seam only and that at the back—the shapely hose of the fourteenth to fifteenth centuries had both back and front of leg fitted with a seam. Early types of hose



Fig. 317.

reached to about 10 inches above the knee and had a point in front to which was attached the lace or string which tied them to a belt. In the fourteenth century, however, the hose was made to reach much higher at the top.

The latest development took place in the fifteenth century when the two legs were joined together by gussets one in front and one at the back. The material used for the smoothest fittings was a woollen fabric which was probably cut on the cross. The numerous attachments by means of "points" round the top edge of the fifteenth-century hose would obviously enhance the excellence of the fitting. An example of hose which have no foot-piece attached but only a species of stirrup or strap underneath the instep is given on the small figure of the dancer or mountebank (see tail-piece, p. 218). No pattern of the hose is given here but it is obvious that to fit neatly they must have followed the exact contours of the person who wore them and been made to order. The rather clumsy and loose fittings shown on some of the manual workers whose costume is illustrated in this volume show perhaps what a "ready-made" or carelessly-cut hose was like.

Fig. 317. (For the origin of this illustration see reference under Fig. 316.) The subject here is that of St. Margaret herding her sheep. The dress will serve to show fifteenth-century costume at its simplest, such as must have been the wear of a young peasant girl, as it might be Joan of Arc. No children's dresses have been illustrated so far in this section but it may be taken boys and girls wore a very simple edition of the dress of their elders, and young girls as a rule wore their hair as in Fig. 317.

Plate VI. is from the "Romance of Renaud de Montauban," illustrated by the Flemish artist Loyset Lyèdet. This manuscript is one of the treasures of the Library of the Arsenal, Paris, and dates *circa* 1470, MS. 5074 f. 62. Here we have the Court Costume of the late fifteenth century in its most characteristic development. The jaunty hats (one surrounded by a crown), the wide padded shoulders, the formally arranged pleats, the extremely short tunic (paltock) of the man on the left and the immensely long shoes or *Poleyns* are typical.

The pomegranate pattern on the tunic of the man on the right is also characteristic of the period, though its popularity survived far into the sixteenth century. The waved hair is also noteworthy.

The figure on the left represents Renaud de Montauban, that on the right is Richier de Monbendal, king of Acre (in Syria).

Plate VII., from the same manuscript as Plate VI., shows the female counterpart of the men's dress in the latter picture. It represents the queen of Richier de Monbendal and her train-bearer. The queen's head-dress may be said to have developed from the *Forked* type, which has been previously illustrated on page 174. The padded roll has



APPENDIX TO PLATES VI. AND VII.

Here we have the subsidiary figures from the same picture in the manuscript of which Plates VI. and VII. are the chief points of interest. The trio on the left and the two youths on the right further illustrate late fifteenth-century court costume as worn by persons of lesser rank. The bearded figure who is clad in loose gown, scapular and capuchon (all coloured grey in the manuscript), wears a dress similar in character to that of the Religious Orders. He is not, however, a monk but Maugis the *Enchanter*, cousin of Renaud de Montauban. The miniature from which the figures are taken is one of dramatic interest. It is entitled "The embarkation of Maugis and his horse Bayart from the port of Acre on his return to his home in the country of the Ardennes." Renaud had been ill and Maugis had travelled all the way to Syria to heal him which he did successfully (*vide* Plate VI.!) "with remedies of his own composition." No doubt Sir Thomas Malory, late in the fifteenth century, when writing of the *Enchanter Merlin*, thought of him in just such a costume as that worn by Maugis in this illustration.

disappeared and its place has been taken by an upstanding and stiffened piece of material with gold cresting on the top edge. The veil is adjusted, as it is on the forked head-dress. The heavy necklace, inset chemisette, immensely long and full skirt, all speak of the period. The dress of the lady-in-waiting calls for no comment save that it shows still another type of head-dress characteristic of this very varied age of millinery. The pattern shown on the queen's dress is again of similar type to that in Plate VI., and still another silk pattern is illustrated in Chapter XVI., p. 211, which is much alike in style.

PERIOD IV. TRANSITIONAL TO THE SIXTEENTH CENTURY

The contrast in style and silhouette in the dress of both men and women of this era is well marked when compared with the style of Period III. Yet, as has been previously said, we encounter survivals of a previous age amid current fashions, and careful examination shows that apparently novelties in fashion are really developments of those styles which have gone before.

It will not be so difficult to enumerate the characteristic features of the costume of a man and woman of fashion as in the previous period because there is distinctly more uniformity.

THE MEN.—*Firstly*, we see the shirt of white linen appearing at the neck and sleeves. In the case of the sleeves it was seen in small puffings at wrist and elbow. *Secondly*, the upper garment (paltock or pourpoint) is cut open from neck to waist and the space filled up with a stomacher which is often richly decorated. *Thirdly*, a wide gown of varying lengths

is usually worn which has turn-back lapels in front and long tube-like, hanging sleeves, which have slits near the elbow to enable the arms to emerge. Below the elbow there was a seam and the lower half of the sleeve was tighter, the upper part gathered into it formed a small puff. *Fourthly*, the shape of the shoes has completely changed from that of the long-pointed *Poulaines*, *Poleynes*, or *Cracowes*; it has become an absurdly broad and square-toed type called *Sabbatons* or *Duck-billed Shoes*. This fashion in shoes is said to have originated in Flanders about 1470. *Fifthly*, the hair and head-gear underwent a complete transformation. The hair was worn very long, hanging on the shoulders. A small skull-cap was placed jauntily on the side of the head and a wide-brimmed, rough felt hat was sometimes worn over it, but often carried slung over the arm by a wide scarf attached or else allowed to hang down the back with the scarf (which was needed to keep the hat firmly on the head when in wear), passing round the neck in front. The hat was adorned with an immense sheaf of feathers out of all proportion to the wearer. The quills of the feathers were often decorated by being sewn with pearls at intervals.

THE WOMEN.—The whole trend of women's dress in this *fin de siècle* period of the fifteenth century displays a certain quiet almost demure character when compared with the flamboyant costumes of the middle and late fifteenth century. *First* and most noticeable of all the changes was that in head-gear. Nothing has been said in respect of fifteenth-century hairdressing as yet for the excellent reason that, save in the case of young girls and a few exceptional regal costumes, the hair was scraped away off forehead and neck and hidden under some of the many varieties of head-dress already illustrated. At the end of the century the fashion

of letting the hair hang loosely down the back became very widespread. A jewelled net was sometimes worn covering the crown of the head and that form of hood known variously as the *Gable*, *Pyramidal* or *Kenel* head-dress became extremely popular. It is illustrated at Fig. 350 and is said to be developed from the turned-back portion which was often combined with the *Steeple* head-dress. *Secondly*, the change in the shape of the neckline of the *bodice* is of importance. The opening now tended to be square cut, and like the men, the women often had a stomacher filling up the front of the bodice, the two sides of the latter often being laced together across the stomacher. The sleeves were of three types, the most usual being tight with a long cuff over the hand reminiscent of the mid-fourteenth century, but instead of the fourteenth-century rows of buttons, these fifteenth-century sleeves were decorated with small puffs formed from a loose white linen under-sleeve appearing at the back seam which was only buttoned and looped together at intervals. The second favourite form of very late fifteenth-century sleeve was that of a full soft edition of the bag-sleeve gathered in to the wrist, its gathering and softness giving an entirely different effect from that of its predecessor. The third type of sleeve is similar to that worn by men, namely, fairly loose to the elbow with a tighter part seamed on from elbow to wrist almost like a long cuff. *Thirdly*, the *skirts* were as a rule smoothly fitted on to the bodice, without the full gathering noticeable in the previous period. One curious feature of these skirts, which were just ground length or little more in front, was that if the train at the back were really long it was turned up and buttoned to the bodice at the back of the waist. As the skirts were generally lined with a different colour, or with



Fig. 318.



Fig. 319.



Fig. 320.



Fig. 321.

Fig. 322.

Fig. 323.

fur, this effect gave a curious and distinctive look to the costume. *Fourthly*, the loose circular cloak as an outdoor wrap was still worn by women and we also see the gown such as was worn by men, but in the case of the women it was cut to full length. *Lastly*, the men's *Duck-billed shoe* in a modified form was also worn by women of fashion at this period.

Though the age of illuminated manuscripts was passing away we have one splendid example of the end of the century in the British Museum collection. This is Harley MS. 4425, Flemish, *circa* 1500. The subject is the Romance of the Rose, from which the following illustrations are taken as also Plate VIII. Figs. 319 and 320 show back views of the typical men's gowns and it will be noticed that in Fig. 320 the dagging or snipping of the edges of

the sleeves and hem of gown have survived from the fourteenth century.

Fig. 318, a minstrel, also shows the dagging as well as the parti-coloured or pied colouring still in vogue. The colours of this figure are as follows: cap, brown; outer tunic, flame-colour; right sleeve of inner tunic, green; left sleeve, brown; right thigh, grey; right calf, brown with golden flames embroidered; left thigh as right calf, and left calf as right thigh; shoes, brown.

Fig. 319, cap, red; lapels, green; gown, grey; hat, grey with white feathers; sleeves and hosen, brown.

Fig. 320, cap, red; lapels, rose; gown, blue; sleeves, brown; girdle, pouch and hosen, gold; shoes, brown.

Figs. 321, 322 and 323 are again from the Romance of the Rose. The lady at Fig. 321 illustrates the fashion of

wearing the hair falling naturally over the shoulders and also the popular fashion of a garland upon the head, of flowers, of leaves, or berries. The mantle of this lady seems to be cut much in the same fashion as the men's gowns of the period, except that it is wider and reaches to the ground. The chemisette is high to the neck and is finished off with a necklace. Below the chemisette we see a stomacher with seam in centre and the sleeves of the dress are of the third type, i.e. seamed at the elbow and the top part gathered in to the lower half of sleeve.

The colouring of Fig. 321 is as follows : gown, slate-colour, lined black velvet and edged with gold ; dress, golden brown ; chemisette, white ; stomacher, red ; shoes, black.

Fig. 322. This young man is clad similarly to his fellows in Plate VIII., and Figs. 319 and 320, but the plumes in his hat illustrate the fashion of decorating the quills of the feathers with pearls sewn on at intervals.

Fig. 323 illustrates the second type of sleeve worn by the women of this period and already described on page 186 as being derived from the bag-sleeve, but soft and gathered rather than shaped. The hair is confined in a loose golden net, the stomacher is very wide and the heavy jewelled girdle has a long pendant in front. The colouring is : chemisette, white ; stomacher and sleeves, pale blue ; dress, rose. The dress is trimmed with gold and gold laces are seen to cross the stomacher horizontally.

This manuscript of the "Romance of the Rose" has, besides those eight costumes which have been illustrated, a number of dresses which seem to be survivals from an earlier age, which are of interest. One survival is the costume of an elderly man—the personification of "Genius." He is



PLATE VIII. MAN AND WOMAN IN A GARDEN : END OF THE FIFTEENTH CENTURY



Fig. 324.

dressed in almost exactly similar fashion to Fig. 306, who is, of course, another elderly man of a previous period. Again, the personification of " Dame Nature " wears a tight-fitting dress of fourteenth-century type covered by the *super-côte-hardie* (the latest form of a surcoat). Though her hair hangs down her back in the *fin de siècle* manner she wears upon her head in addition the jewelled cauls surmounted by a coronet, a fashion which dates back to the beginning of the fifteenth century and even earlier.

Fig. 324 wears a more elaborate version of the costume



Fig. 325.

Fig. 326.

Fig. 327.

of Dame Nature just described. This illustration is taken from a portrait of Margaret of Scotland, daughter of the King of Denmark, who married James III., King of Scotland, in 1469. The painting, which dates *circa* 1482-84, has been reproduced in Shaw's *Dresses and Decorations of the Middle Ages*, from which the information given above is quoted. Fashions in the Middle Ages originating on the Continent often took a considerable time to migrate to come to England, perhaps even twenty or thirty years on occasion. Though Scotland was more remote, there was considerable direct intercourse with France, hence it may be that this costume is not so much "old fashioned" as *regal* in character. On her effigy, dating earlier in the century, Joan of Navarre, consort of Henry IV., is represented as wearing the *super-côte-hardie*, and "Dame Nature" already referred to may be considered to be wearing the dress of a queen.

Besides the richly jewelled coronet and net on her head, Queen Margaret has the massive necklace of her time, and in addition a jewelled plastron of extreme magnificence covers the ermine of her *super-côte-hardie* and cloak, which latter is attached to the back of the former garment. The tight sleeves and closely fitting body of the long robe underneath are made of a magnificently patterned late fifteenth-century silk of characteristic type. The colouring is as follows: cloak and *super-côte-hardie*, deep purple, trimmed ermine and lined red; the dress underneath, yellow, with the pattern in red outlines.

Figs. 325 and 327 represent Charles VIII. of France (1470-1498) and his consort, Anne de Bretagne. Here, indeed, we have a contrast from the stately and elaborate costume in the portrait of Margaret of Scotland. The French royal pair are, of course, represented as dressed merely for ordinary occasions. The King wears two gowns, an inner one lined with fur and an outer one of a typical fifteenth-century patterned silk. His white shirt shows at the neck, the doublet or tunic worn over it is only visible at the wrists, where, again, we can see the white shirt puffing out at the back of the sleeve. The plain cap on his head was of the type we in England associate with the reign of our Henry VII. The Queen, Fig. 327, wears a dress of the utmost simplicity, suggesting some of the present-day survivals to be seen in French peasant costume. Her necklace is of small pearls only, and her girdle, though massive, shows only as a plain chain of metal links.

In Fig. 326 we have the portrait of the Dauphin, Charles Orland, painted in 1494. This delightful child's costume speaks for itself. The seams on the hood show clearly the method of construction. The bib is apparently fastened on



Fig. 328.

Fig. 329.

Fig. 330.

with pins. The fine pattern of the silk is not unlike that worn by the King.

In the Cluny Museum in Paris there hangs a mysteriously beautiful tapestry called "The Lady and the Unicorn" ("La Dame à la Licorne"). Guiffrey, in his *L'Histoire de la Tapisserie*, says: "Its origin is uncertain and obscure." As the crescent appears in many parts of the design it is thought perhaps the tapestry may have been ordered by an oriental potentate to whom it was never delivered. There are six large panels, each with the portrait of a woman, young, slim, blonde and tall, arrayed in six different dresses of the mode of the end of the fifteenth century. We may note that in one of the costumes, Fig. 330, a very late form of the *super-côte-hardie* appears. The weaving



Fig. 331.



Fig. 332.

is considered to have been done at Aubusson, and there is a legend that Marie de Blanchefort, niece of Pierre d'Aubusson, was the original of the lady. She is represented as holding a banner (Fig. 328), dressed for the chase (Fig. 329), playing the portable organ (Fig. 330). It should be said that the patterning on the various costumes of this lady include the rich artichoke or pomegranate pattern (similar to that in Plates VI. and VII. and Fig. 346) as well as the "watered" silk design as seen at Figs. 328, 329 and 330. It has not been possible to include the larger pattern in the small-scale drawings, but it is shown in the two other panels (Figs. 331 and 332). Here she is making a garland from flowers gathered by her young girl attendant, and again she chooses jewellery from a casket.

These five costumes, Figs. 328-332, vary considerably from those illustrated from the Romance of the Rose, and yet they are undoubtedly in the same style. One feels that the designer of the costumes in the Lady and the Unicorn tapestry was an artist of originality and distinction. The background of the Lady and the Unicorn tapestry is a very beautiful example of the "flowery meadow" type of design popular at this period. Pansies, pinks, cowslips, periwinkles and other flowers too numerous to mention are strewn over the field with a grace and abandon which captivates the beholder. For an example of such flowers in detail, see Fig. 449*b, c, d* and *e*.

Before the end of the fifteenth century the influence of ancient Greek and Roman art had become a factor in determining the style of Italian costume. In the dress of the women this is specially noticeable. The exaggerated head-dresses which were the vogue in France, England and the Netherlands were not popular in Italy where the simply



Fig. 333.

Fig. 334.

Fig. 335.

Fig. 336.

dressed heads with which we are familiar in the works of the great painters of the period illustrate the difference in taste. This influence is seen in Figs. 333–336, which are from a page of the Choir Book of St. Catherine of Alexandria. The original is in the Victoria and Albert Museum, London (No. 817 of 1894), *circa* 1475.

The miniature represents St. Catherine of Alexandria disputing with the Grammarians and Rhetoricians before the Emperor Maxentius. The colouring is as follows: Fig. 333, cloak, green; dress, blue; shoes, black. Fig. 334, hair bound with white ribbon; dress, rose colour with green sleeves. Fig. 335, cap, red; fur-trimmed tunic, green; sleeves, blue; one leg rose and the other green. Fig. 336, capuchon, blue; fur-lined robe, rose; inner tunic, green; shoes, red.

CHAPTER XV

ARMOUR IN THE FIFTEENTH CENTURY AND
DETAILS FROM METAL ORNAMENTS

AFTER 1400 we find the transitional type of armour which bridged the period between chain mail and full plate gradually disappears, and by 1410, the *camail* which filled the gap between the *bascinet* and the body-armour, has given place to the *gorget*. The body itself is defended also by plate armour so that instead of the *jupon*, *gambeson* and *hauberk-of-mail* we find the *cuirass* now covering breast and back with the *brayettes* or *taces* which form a short petticoat or skirt of steel hoops. The armpits are now defended by *roundels* or *palettes* and the *coudières* at the elbows have become larger and developed *flanges* to guard the inner elbow. *Epaulières* still cover the shoulders, and the *bascinet* continues to be worn as a headpiece though slightly modified in form. The leg-armour is little altered from that in use in the previous period.

All these changes and developments are well shown in the memorial brass of Sir Robert Suckling, of Barsham, Suffolk, *circa* 1415, see Fig. 337. Points not yet mentioned which can be observed in this brass are the change in the manner of wearing the sword-belt—now slung diagonally across the front instead of round the hips. The belt itself is narrower. The initials on the scabbard are characteristic



Fig. 337.

of the period, also the pear-shaped pommel of the sword. The "collar of 'SS'" is worn over the gorget; for description of this collar see Fig. 341. One observes also the two small extra brayettes or taces which are attached to the skirt. The fluted and scolloped metal of the flanges of the *coudières* are shell-like in form and an early example of that treatment of the metal which gives "the golden age of armour" at the turn of the century much of its beauty. The flutings, however, were not merely of æsthetic value, they served a useful purpose in assisting to deflect the point of an attacking weapon. Finally, in the brass of Sir Robert Suckling we notice the small dagger or "misericorde" which is attached by a loop to the lowest tace of his

skirt of plate on the right side.

That great authority on armour, Sir Guy Laking, has said of the period 1400-1500, that its history is so complicated there is a great difficulty in getting a clear view. When the different details of fifteenth-century armour, such as headpiece, sword and spur are discussed, each in a separate chapter of considerable length by this author, it

will be realised that it is impossible to gain a real knowledge save from specialised books and collections in museums. We may, however, make a useful beginning to such study by examining certain typical examples. The brass of Sir Robert Suckling having been reviewed as characteristic of *circa* 1415 we now turn to Fig. 338. The effigy of Richard Beauchamp, Earl of Warwick (who died in 1439), is considered to be the most beautiful work of its time and as an artistic achievement and faithful record of fact it is said to have no equal in England. The Earl lies recumbent upon his tomb in the Beauchamp Chapel, St. Mary's Church, Warwick. The year 1454 is held to have been the date when this effigy was completed, though the design of the armour would appear to be nearer in style to that in wear towards the end of the century. This question of style, however, is accounted for by the fact that the Earl of Warwick most probably ordered his armour from Milan, the work of whose famous smiths was the admiration of Europe and where the technique and design was in advance of that of any other city, though Nuremburg in Germany became also a place of great renown for its armourers about this period. The Italian painters, perhaps most of all Mantegna, delighted in depicting armour, and this artist's magnificent figure of the great warrior Saint—George—painted late in the fifteenth century, wears a suit of armour almost identical in design with that of the Earl of Warwick. To describe Fig. 338 in detail, we notice first the helmet and crest under his head. First, as to the helmet, Planché tells us that it "undergoes a change about this time" in that it "takes the shape of the crown of the head and neck at the back," in fact approaches in form that of the *Salade*, a species of headpiece which will be

described later in this chapter. Though the Earl's head covers his helmet to some extent, this curving inwards at the back of the neck can be observed in the drawing. The heraldic description of the crest is as follows: "Out of a ducal coronet, *or*, a demi-swan, *argent*" (for Beauchamp). Coming to the shoulders of the effigy we see they are protected by extra pieces of plate called *pauldrons*, which came into fashion about 1410. These are independent shoulder-guards which overlap the cuirass. About 1430 we begin to find left-hand *pauldrons* and *coudières* larger than those on the right, as the right arm was more easily protected, and also this arm required more freedom to wield the sword. Next to the pauldrons on the shoulders we notice that the *cuirass* (breast and back plates) is divided into two parts—upper and lower. The lower one being on the outside and the upper one sliding underneath it, but kept in place by a strap and buckle.

The *coudières* are very large and the flanges seen on the arms of Sir Robert Suckling are in the Earl's effigy, much larger; also it will be noticed the left one is more massive than the right. Holes near the right pauldron show where a gusset of plate has formerly been fixed, probably as a rest for the lance. Two large pieces of plate called *tuilles* hang over the *cuissards* (steel plates protecting the thighs). The *tuilles* are fastened by straps to the skirt of plate. The *genouillières* have flanges on the outside of the knees and the whole of the leg-armour is more elaborate and divided into smaller plates than that of Fig. 377. The garter which is seen in wear on the left knee will be described later in this chapter. The dagger or *misericorde* is lost. The pommel of the sword is ornamented with one of the Earl's badges, in heraldic language, a "Musled (muzzled) bear." The

whole suit of armour on this effigy is represented with the utmost exactitude. Each strap, fastening, buckle and hinge are clearly shown. Fig. 338, the front view, is copied from Stothard's *Effigies*, and in this volume Stothard has beautifully-drawn representations of the back view, left- and right-side views as well as enlarged renderings of much of the detail. Besides the changes already described which had taken place in the period elapsing between the armour of the earlier and late fifteenth-century types shown at Figs. 337 and 338, we should note the popularity of two types of headpiece, the *salade* or *sallet* and the *armet*.

The latter really belongs properly to the sixteenth century, but the *salade*, a German headpiece (German, *schale*—shell), had for its principal characteristic a shell-like projection at the back of the neck. Some types came well down over the eyes, leaving a horizontal slit for vision, others were fitted with moveable visors, and again a third type called the Venetian *Salade* had cheek

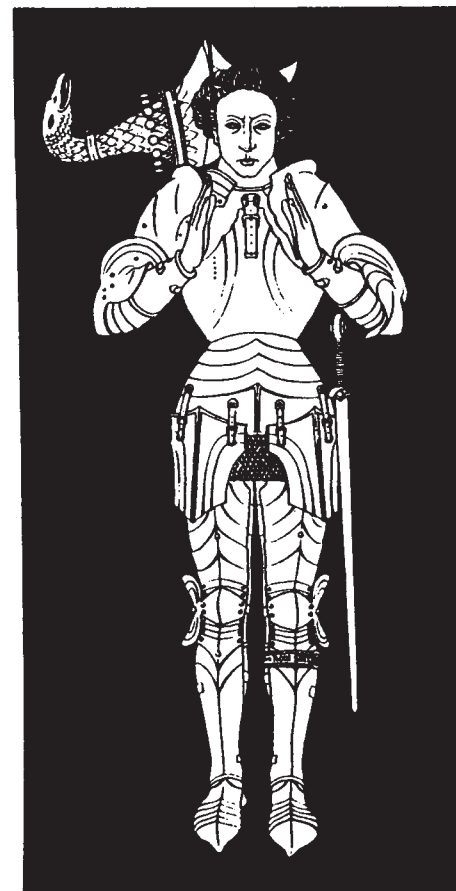

Fig. 338.

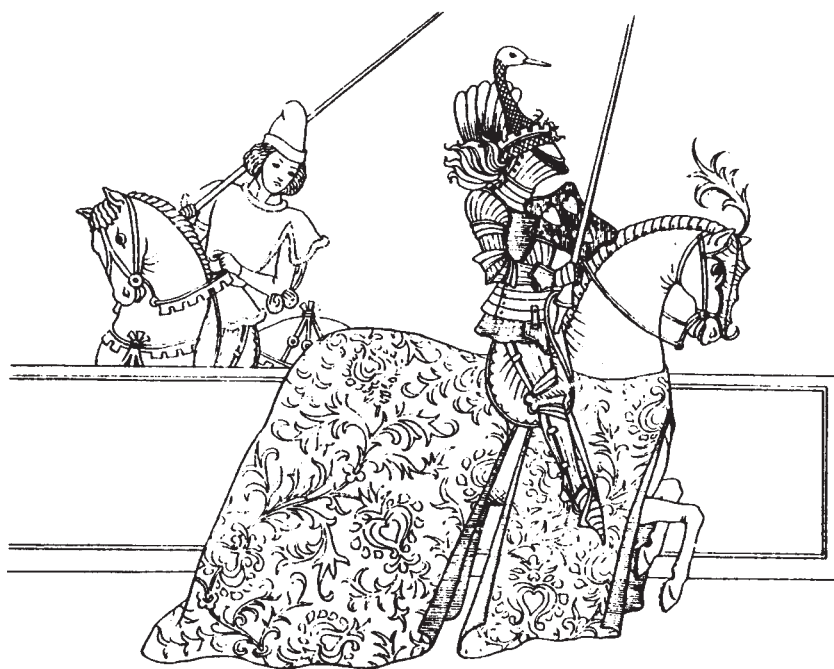

Fig. 339.

defences resembling those on an ancient Greek helmet. The shape of the *salade* survives in the steel head-covering of the modern German army though now entirely lacking in the embellishments and elaborations which gave the medieval progenitor such a romantic beauty.

Fig. 339 is from a miniature in the British Museum MS. "Froissart's Chronicle," Harl. 4379, 4380, f. 23b, French, late-fifteenth century. This particular illustration (f. 23b) is entitled "The Jousts of St. Ingleuerch." It represents a procession of knights and esquires riding round the barriers at a tournament with tents in the background, and again behind that ladies and gentlemen spectators. While full of life and action there is not, of course, owing to the small

scale of the drawing, much accuracy of detail, but the figure of the knight in armour can be compared with that of Sir Geoffrey Luttrell (p. 100) arming for the tournament, a strikingly different figure from his late fifteenth-century compeer.

DETAILS FROM METAL ORNAMENTS

Nos. 340*a, b, c, d, e* and *f* are from the Effigy of Henry IV. (1399-1413) and that of his Queen Joan of Navarre. The tomb is in Canterbury Cathedral and is considered one of the most beautiful of our regal monuments.

Apart from the ornament as illustrated in this chapter the costumes themselves show very little difference from those worn by Richard II. and his Queen Anne of Bohemia (Figs. 211 and 212). In King Henry's costume we find the differences chiefly in his short-cropped hair, a fashion characteristic of the first quarter of the fifteenth century; see also the heads of the men in Fig. 292. The traditional regal state dress of England is here shown. The cape or tippet as introduced at the end of the fourteenth century and seen on the effigy of Richard II. is similar, but the sleeves of the dalmatic or outer tunic are wider in the costume of Henry IV. and the garment also shows deep pocket slits edged with jewelled embroidery as are also the sleeves and hem.

The royal mantle or cloak is truly magnificent with its jewelled strap across the breast and lozenge-shaped clasps and cords. The glory of the whole dress is, of course, the celebrated "Harry" crown which is said to be an imitation of the one which Henry V. broke up and pawned in 1415 to pay for his wars in France. This diadem is surrounded by alternate crestings of oak leaves and fleur-de-lis, below

are jewelled bands with sapphires, rubies and pearls, these set amid borders of leafage in chased gold. The crown, jewelled cloak, fastenings and jewelled embroidered borderings are illustrated at Figs 340a to f as follows :

Fig. 340a. The crown and cloak fastenings.

Fig. 340b. Detail from the crown enlarged.

Fig. 340c and f. Jewelled borders from the robes.

Fig. 340d and e. Cloak-fastenings enlarged.

The figure of Joan of Navarre in this royal effigy has a crown almost equal in richness to that of the King. Her costume is almost exactly the same as that of Anne of Bohemia, Queen of Richard II. (Fig. 211), save that her cloak is held in place by jewelled fastenings similar to those of her husband, and she wears a *super-côte-hardie* of the type worn by Mary, Duchess of Brittany, daughter of Edward III. (Fig. 191, p. 108). Round the Queen's neck we observe a "collar of 'SS'" (Fig. 341). This was the favourite badge of Henry IV. and next to the famous "Garter" it was the most celebrated decoration of the age. Its origin and meaning are uncertain. Boutell says that the "S" is the initial letter of the word "*Souveraine*," motto of Henry IV. when Earl of Derby. It is also found, however, round the arms of John of Gaunt, Duke of Lancaster, who was also *Steward* of England, so that the "S" may stand for "*Seneschallus*." It is at all events a badge specially pertaining to the House of Lancaster and was granted to his personal followers at court as a special favour by Henry IV. Figs. 342a, b and c are from the effigy of John de la Pole, Earl of Suffolk (who died in 1491), from the Collegiate Church at Wingfield, Suffolk. The effigy is illustrated by Stothard. Fig. 342a is the Garter. This most celebrated



of all English Decorations was founded by Edward III., *circa* 1348. The Garter itself was a strap of sky-blue velvet edged with gold and bore the motto "Honi Soit Qui Mal Y Pense" in gold embroidery. The buckle and tongue were either gold or silver gilt. It was worn by knights on the left leg and by ladies on the left arm. The mantle was of blue woollen cloth and on the left shoulder was embroidered the motto surrounding the shield of St. George ("argent a cross *gules*") to whom the order was dedicated. The Garter can be seen in wear upon the armour of the Earl of Warwick (Fig. 338). The full insignia of the Order includes Mantle, Hood, Collar, Badge and Garter. Most of the works on heraldry (*see* Bibliography) include a very full description of the Order of the Garter.

Fig. 342*b*. Portion of the sword-belt of the Earl of Suffolk, shows the narrow diagonally-worn belt of the later fifteenth century. The buckle fastening having its place high up on the right side. If a sword-belt had been present on the effigy of the Earl of Warwick (Fig. 338) we can think of it as being similar to Fig. 342*b*. Fig. 342*c* shows the sword-hilt and scabbard from the same effigy. The pear-shaped pommel of the sword recalls that of Sir Robert Suckling (Fig. 337). The decoration shows a style not quite so homogeneous as that of similar accoutrements pertaining to the Black Prince (*see* Figs. 229*a* and *b*, p. 127). Fig. 343 is an enlargement of the detail from the jewelled net of Margaret, Queen of James III. of Scotland (Fig. 324, p. 191).

CHAPTER XVI

FIFTEENTH-CENTURY ORNAMENT AS APPLIED TO WOVEN MATERIALS AND EMBROIDERIES

THE magnificent patterned silks, velvets and gold tissues which so enriched the costumes of the fifteenth century may be said to have a purely æsthetic appeal. Gone are the dogs and deer, clouds and ship's sails and all the other exciting creatures which give such vitality to the designs of the thirteenth and fourteenth centuries. Instead we have for the most part purely conventional forms based on the vine leaf and on forms which suggest the pomegranate and the artichoke. Very many of the finest pieces which fill our museums are of North Italian origin. The three specimens which have been selected, represent the principal motifs and arrangements, but it is difficult to give a precise date for them. We may say, however, that Figs. 344 and 345 precede the more elaborate example Fig. 346, but at the same time the two former do not die out nor are they completely superseded by the later type of pattern. Figs. 344 and 345 are not taken from actual silks but from those background-patterns in imitation of them which the medieval artists delighted to paint and which are common to the art of several European countries, including England, France, the Netherlands and Germany. Fig. 344, one of the simplest types of these designs, shows a vine leaf with an alternating pomegranate and artichoke pattern imposed



Fig. 344.



Fig. 345.

upon it, or as the late William Morris used to say, a vine leaf "*inhabited*" by pomegranates and artichokes. This type of design is well calculated to give a full and rich effect, at the same time it allows sufficient blank spacing to show off the rich sheen of a velvet or satin surface.

The Victoria and Albert Museum has many actual examples of such textiles. Some in medieval vestments and some as separate fragments almost identical in design with this medieval painting. One piece, "No. 1339 of 1864, Victoria and Albert Museum" (rather more elaborate than Fig. 344), has a ground of green satin with the pattern in crimson, yellow and white. The label reads "Italian; fifteenth century." Fig. 345 is an unusual and rarely



Fig. 346.

beautiful development from Fig. 344. It has been chosen as being a sort of *bridge* design between Figs. 344 and 346. It has the simplicity of the first and the swaying movement of the second. The original is in the painted background of a picture by Stephan Lochmer in Cologne Cathedral. Fig. 346 is similar in type to the designs seen in wear on persons in Plates VI. and VII. and also in two of the costumes worn by "The Lady" ("La dame à la Licorne"), see Figs. 331 and 332. Again at the Victoria and Albert Museum we can see many varieties of this design. The prevailing colour schemes display a great amount of gold tissue and deep red velvet. One magnificent specimen is gold on deep blue, and the scale of the patterns is often even larger than those shown on Plates VI., VII. and Figs. 331 and 332. Many of these later patterns are also, like Figs. 344 and 345, of North Italian manufacture.

EMBROIDERY PATTERNS IN THE FIFTEENTH CENTURY

The Heraldic Tabard must not be omitted when describing Medieval Costume of the fifteenth century. This was a development of the surcoat or jupon. The herald's tabard should not be confused with the "academic tabard" or "taberdum" referred to at Fig. 270, p. 155, nor with the simple garment worn by the trumpeter at Fig. 315, p. 179.

Fairholt describes the Heraldic Tabard as the "emblazoned surcoat of a herald or a knight upon which his arms were exhibited." He tells us at the same time that a "herald's coat was on some occasions improvised out of the banner of a trumpet" (at times the medieval trumpeter had a heraldic banner attached along the length of his trumpet).

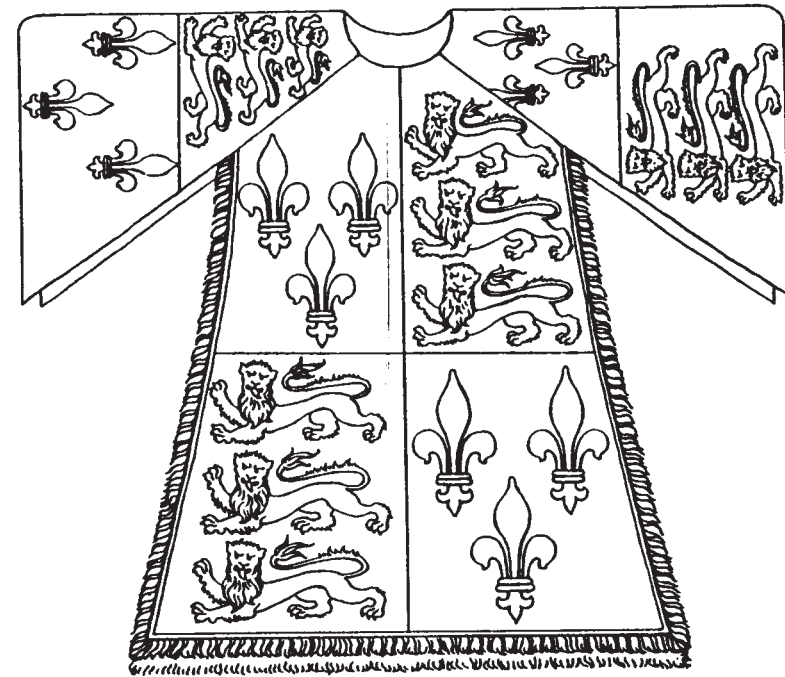

Fig. 347.

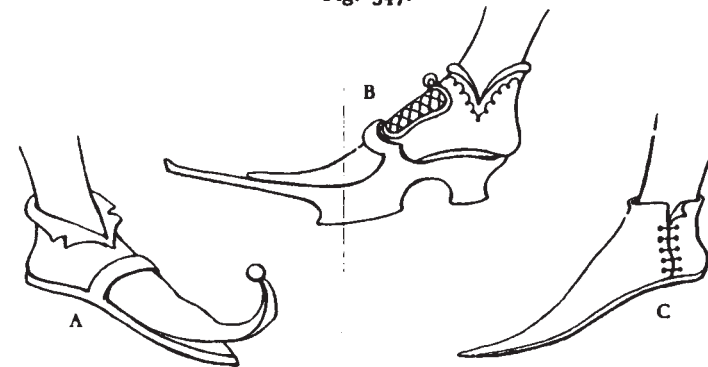

Fig. 348.

In "the Warwick Roll," Richard III. is represented fully armed, in plate, over which he wears a tabard emblazoned with the royal arms. Fig. 347 is copied from B.M. MS. Add. 6298 fol. 148. This is a sixteenth- or very early seventeenth-century drawing, in outline, of "The Tomb and Achievements of King Henry VI. in St. George's Chapel, Windsor." The "achievements" included helm, tabard, shield, sword and gauntlets. They were removed between 1598 and 1613 but the drawing gives us a faithful representation of a late fifteenth-century heraldic tabard. The tabards were made of silk and velvet laid on to linen or other stout material for lining and the heraldic devices were embroidered partly in appliqué and partly in stitchery. The heraldic description of the arms of Henry VI. are "Quarterly, 1st and 4th, France; 2nd and 3rd, England." The Victoria and Albert Museum has several specimens of tabards but none of as early a date as the fifteenth century. One very fine example is "No. T.174 of 1923." The label reads: "Tabard velvet and silk brocade with applied heraldic embroidery. Probably made for the Lyon King-of-Arms, Scottish; seventeenth century, H. 3 ft. 3¼ ins., Gt. W. with sleeves, 5 ft. 1½ ins." An excellent postcard photograph of this tabard is published by the Museum.

Fig. 348*a*, *b* and *c* are placed here instead of being given in an earlier chapter owing to the lack of space. Fig. 348*a* is a clog or *cracowe* (the term seems to be applied to both clogs and shoes of the long-pointed type) from Planché who labels it "after Viollet-le-duc from a French painting"; it shows the absurdly long toe of the shoe it protects, with what may be a small ring at the tip. Planché mentions *cracowe* as being derived from the name of the city of Cracow and the other term Poulaine or Poleyne

from Pologne (Poland). While medieval writers of the late fourteenth and early fifteenth century refer to the fashion of fastening these very long-toed shoes by chains to the knees, Planché says, "No pictorial illustrations of these chained-up shoes appear in any of the illuminations of this period," but he refers to "a portrait of James I. of Scotland existing at Keilberg in Swabia" "where the King's shoes are fastened by chains of gold to his *girdle*." Fig. 348*b* is copied from Shaw who quotes it as being from B.M. Ms. Cott. Julius E. iv. The clog is coloured brown, the shoe blue, embroidered gold, and the hose fawn colour. Fig. 348*c* is from Planché who also quotes it as "Temp. Ed. IV. from an original in the collection of R. Smith, Esq." Fig. 349*a*, on p. 217, is the back view of a chasuble already illustrated in plan (Fig. 260, p. 145, "No. 696 of 1902, Victoria and Albert Museum, late fifteenth- or early sixteenth-century English"). Here we have an embroidery design, characteristic of the age of which there are several other examples in this museum's collection of church vestments. It is clear that the design of the ornament has been developed from contemporary textile patterns such as Figs. 344-346, but the technique of the embroidery has given a fresh character. This is chiefly due to the design being partly in appliqué, and partly in stitchery on the ground itself (dark blue velvet in this particular instance). That is, the heavier central part of each motif is of appliqué and the lighter more feathery details are in direct stitchery on the background. This chasuble has most probably been cut out from an embroidered cope, hence the ornament overflows the space in its present form.

Figs. 349*b*, *c*, *d* and *e* are an example of naturalistic design contrasting with previous examples of fifteenth-

century ornament given in this chapter and Chapter XV., which may be said to be of conventional or formal type.

Figs. 349*b* to *e* are really of early sixteenth-century date and from the background of a tapestry called "The Three Fates" (Victoria and Albert Museum, No. 65 of 1866). They are, however, so very similar to the flowers which form the background of the late fifteenth-century tapestry, "The Lady and the Unicorn" (pp. 194-197), that they can take their place as contemporary with late fifteenth-century examples. This beautiful medieval method of covering a background with a medley of flowers must have been used in embroidery as well as in tapestry. A reference has been previously made (on p. 119) to Chaucer's description of the young squire's "côte-hardie" being embroidered with red and white flowers "like a meadow" in connection with these four flowering plants here illustrated.

Figs. 349*f*, *g* and *h* are examples of that formal foliage or "scroll-work" which has also been illustrated in the thirteenth- and fourteenth-century sections of this volume.

Fig. 349*f* is from a B.M. Ms. (Add. 18850, Bedford Hours, French, circa 1423). Fig. 349*g* is from a pierced iron hinge (German late fifteenth century). Fig. 349*h* is from a carved wood beam (Swiss, late fifteenth century). Each of these scroll-work leaves has the impress of the tool, *i.e.* brush, hammer and chisel, yet each has a character which marks it as distinctly of the fifteenth century. Figs. 349*i*, *j* and *k* are from the same M.S. as Fig. 349*f* and show again the teaching of another tool—the pen. The flowers are filled in with the brush but the stalks and tendrils are in pen-work. Medieval pattern designers were

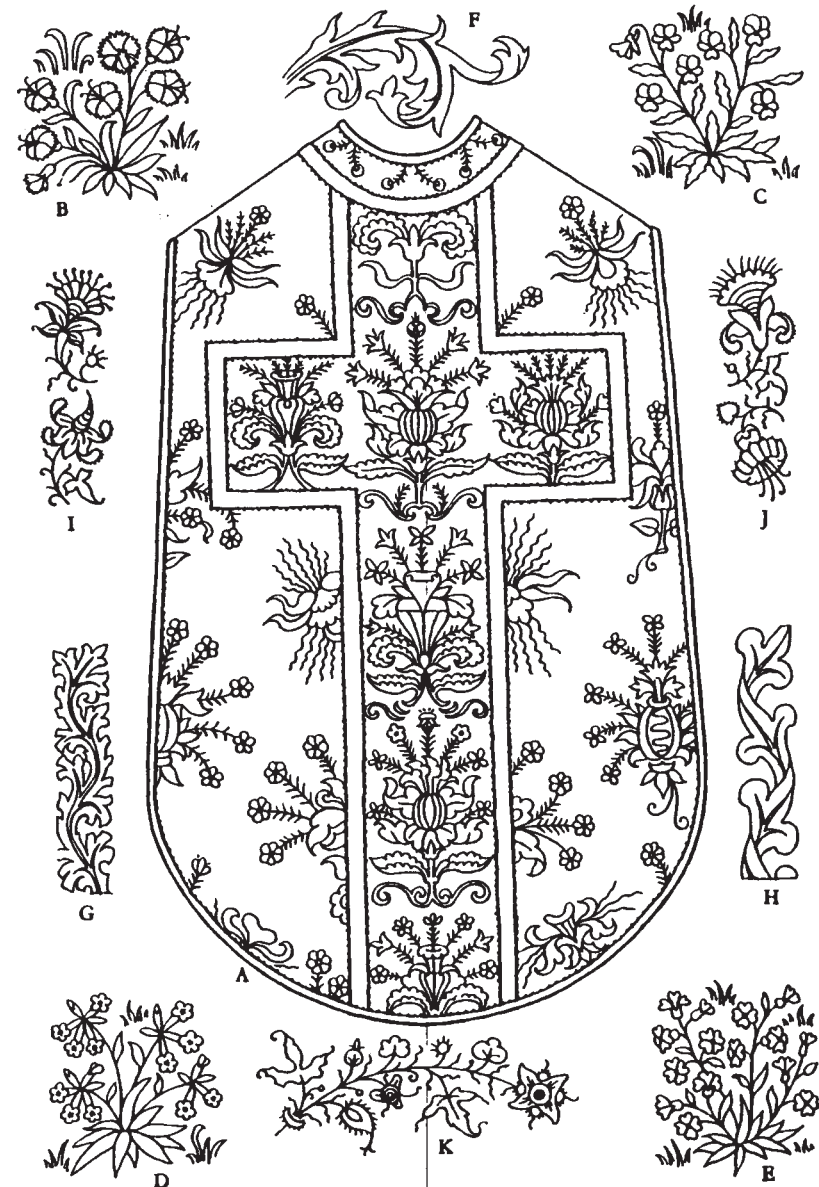

Fig. 349.

constantly inspired by one another. An instance has been given at Fig. 349*a* where the embroidery designer has been inspired by a woven pattern, hence it will be seen that there is reason for including patterns from iron and wood-work in this chapter. The richness and variety of late fifteenth-century dress-materials can be imagined from the written inventory of the wardrobe of Richard III. He possessed among many other garments "a doublet and stomacher of blue cloth-of-gold, wrought with netts and pyneapples; a long gown of purple velvet furred with ermine; shoes covered with crimson tissue cloth-of-gold; hose of crimson satin," and perhaps more splendid still, "a long gown of purple cloth-of-gold wrought with garters and roses and lined with white damask, which was the gift of the queen."

Fig. 350 is an example of the richly jewelled embroidery as applied to costume at the close of the fifteenth century. The portrait is that of Elizabeth of York, Queen of Henry VII. She is wearing the "Kennel" or "Gable" head-dress so characteristic of this period.



GLOSSARY

BEING a list of Medieval words which are of most frequent use in the nomenclature of Costume and Armour. Those words, the meaning of which have been already fully explained in the text, are referred back to the pages on which they occur without further comment. In other cases, where explanations are given, a reference back helps with illustration.

Acketon. Also Aketon, Hacketon, Hauketon, and Gambeson, pp. 123, 124.

Agrafe. A large brooch for fastening cloak or robe, pp. 13, 55.

Agraffes. Hooks and eyes used for armour and also for ordinary costume.

Aiglets. Also Aiguillettes, metal tips sheathing the ends of the laces or "points" used for tying the different parts of a costume together, p. 181.

Aillettes. Pp. 61, 100.

Alb. Pp. 21, 23.

Almoner. Also Aulmonière, purse or bag looped by a cord to the girdle, used for almsgiving, pp. 13, 55.

Almuce. Pp. 93, 155.

Amice. Pp. 21, 23.

Anlace. Also Anelace, a short sword or dagger worn by civilians, pp. 160, 161.

Apparels. Pp. 22-24.

Arming-doublet. See Acketon.

Arming-points. Small thongs of leather for tying the Camail to the Bascinet or the Roundels to armpit, etc.

Aumusse. See Almuce.

- Baguette.* A lappet of mail, see Little Brayettes.
- Bainbergs.* Also Bamberges, armour for the lower part of the leg.
- Balandrana.* A wide cloak worn by travellers in the thirteenth and fourteenth centuries.
- Balays.* Pink rubies.
- Baldric.* Also Bawdric, a wide belt, usually decorated, worn round the hips, pp. 112, 127; or, passing over the shoulder, often hung with bells, pp. 163, 167.
- Bamberges.* See Bainbergs.
- Barbe.* Pp. 118, 152.
- Barmecloth.* An apron, p. 102.
- Barred.* Striped, see Plate III.
- Bascinet.* Also Bacinet, a globular pointed helmet of the fourteenth and fifteenth centuries, pp. 112, 123, 127.
- Baselard.* A dagger or Anelace.
- Baudekyn.* Textile fabric of rich silk and gold tissue.
- Bawdric.* See Baldric.
- Beavor.* Armour protecting the face.
- Bise.* A species of fur.
- Bliant.* Also Bliaus. A garment worn by both sexes, said by some authorities to resemble the surcoat. Sometimes lined fur.
- Bouchette.* Buckle fastening the lower part of breastplate to the upper one, p. 203.
- Bourdon.* A walking-staff, a pilgrim's staff, p. 97.
- Brassarts.* Also Demi-brassarts, steel plates for the upper arms (Rere-braces) and forearms (Vambraces), pp. 112, 123.
- Brayette.* Also Braguette, steel petticoat or skirt of overlapping bands. Little Brayettes, small plates added at bottom centre front, p. 200. See also Taces. The Baguette (of mail) was used for the same purpose as the Little Brayettes (of plate).
- Buskins.* High boots worn by country folk and travellers, also part of the King's Coronation Vestments and of the Vestments of the Bishop at High Mass.
- Bycocket.* A hat turned up behind and down in front; when worn by kings it was circled with a crown. It was similar to the "Chapeau," sometimes worn by knights over their helmets.

- Camail.* The mail protection depending from the lower edge of the Bascinet, pp. 112, 123, 127.
- Capa.* A hooded robe or mantle, also worn without hood, p. 93; or with cape, p. 155; a word of general reference.
- Cappa Nigra.* Black choir-cope, see again pp. 93 and 149. A word of special reference.
- Cappa Clausa.* Closed cope, see again p. 155. A word of special reference.
- Capuchon.* Also Chaperon, a hood. Planché calls the pre-fourteenth-century hoods "Capuchons or Cowls," those of fourteenth century Chaperons, which name he also applies to the fantastic "bundles," as he calls them, developed from fourteenth-century types which we find in the fifteenth century. Numerous illustrations of hoods of all types occur throughout this volume.
- Caputium.* Pp. 154-156.
- Casque.* A helmet.
- Cassock.* P. 150.
- Caul.* P. 68 and numerous other examples on later pages.
- Cendal.* A woven silk material.
- Chain Mail.* Pp. 55, 58.
- Chapel-de-fer* or *Chapelle-de-fer.* Iron hat-of-war, p. 111.
- Chaperon.* See Capuchon.
- Chasuble.* Pp. 24, 25.
- Chausses.* Also Hose or Hosen, tight coverings for the legs.
- Ciclatoun.* Also Siglatoun, a very rich woven material.
- Cingulum.* A waist belt or cord.
- Cognisance.* Heraldic term for badge of a noble family.
- Coif.* A close-fitting cap, popular head-dress for men in the thirteenth century, pp. 47, 51, etc., also see special reference, p. 157.
- Coif-de-Mailles* or *Mail Coif,* pp. 60, 61.
- Cointise.* Also Quintise, quaintly and fancifully cut.
- Colobium.* A plain tunic, forerunner of the Dalmatic.
- Cope.* Pp. 30, 31.
- Cordovan.* Fine Spanish leather.
- Côte.* Also Courtepy, Kirtel, Kirtle, a woman's gown.

Côte-hardie. A tight-fitting tunic when worn by men, a long tight-fitting gown when worn by women.

Coudières. Also Coudes or Coutes, pp. 112, 125, 199, 202.

Cowl. See Capuchon.

Crespine. Pp. 86, 87.

Cuirass. Pp. 199, 200, 202, 203.

Cuir-bouilli. Boiled leather, which became so hard and durable by this treatment that it could be used for armour.

Cuisses. Also Cuissarts and Cuissards, p. 125.

Cyclas. P. 123.

Dagges. Ornamental cutting of the edges of garments, dating from circa 1346.

Dalmatic. Pp. 25, 27.

Damask. A rich patterned material originating at Damascus; made later in Sicily, Italy and France.

Demi-Brassarts. See Brassarts.

Diaper. Embroidered or diversified with ornament.

Doublet. This short tunic was originally made of double material with padding inside. It was tight fitting.

Dunster. A broad cloth made in Somerset, known early in the fourteenth century.

Enarme. The attachments at the back of a shield by which it could be held on the arm.

Epaulières. Pp. 125, 199, 200.

Ermine. The most valued fur, it took its name from Herminia (Armenia), worn by Kings, Princes and Nobles.

Falding. A coarse woollen cloth.

Frontlet. A band for the forehead worn by women, made in cloth, silk, velvet, and gold, pp. 176, 177.

Frounce. Fourteenth-century term for flounce.

Fustian. A cotton or woollen cloth.

Gadlyngs. Steel plates or bosses seen on the gauntlets, p. 200.

Gambeson. See Aketon.

Gardcorp. An outdoor garment worn by men and women, possibly as Fig. 76, p. 47.

Gauntlet. The gloves of a knight in plate armour, they were lined with leather, p. 200.

Genuillières. Knee-guards. First made in cuir-bouilli, afterwards of steel, pp. 123, 200, 203.

Gipcière. A leather pouch (cuir-bouilli). It was attached to the girdle.

Gipon. Similar to the Gambeson but eventually worn by itself and became the Pourpoint.

Gite. A gown.

Gonfanon. A small banner charged with a knight's coat-of-arms attached to his lance.

Gorget. Throat armour, p. 200.

Greaves. Also Jambes, plate armour to protect the shins.

Gris. Grey fur from the martin, next in value to ermine and sable, worn by well-to-do middle classes.

Guige. Strap to suspend the shield round neck or shoulder, p. 61.

Harness. Armour.

Hauberk. A coat of mail, pp. 45, 59, 61.

Hauketon. See Acketon.

Helm. Also Heaume, a helmet, special reference "tilting helm," p. 124.

Heuke. An outer garment or cloak worn by men and women in the fourteenth and fifteenth centuries.

Hose. See Chausses.

Infulae. Pp. 34, 35.

Jambarts. Plate armour for the shins, p. 125.

Jambes. See Jambarts.

Jupon. Also Gipon, pp. 121, 125.

Kendal or *Kendal-green.* A cloth made in Westmorland as early as 1389.

Kennel Head-dress. Also Gable and Pedimental Head-dress, pp. 186, 218.

Kirtle. Also Kirtel, a loose gown, a tunic or waistcoat.

Latchet. The strap used to fasten a shoe or clog.

Lettice. A species of fur of a pale grey shade.

- Mahoitres.* The padded shoulders of late fifteenth-century costume, p. 173.
- Mammelières.* Steel roundels with staples fastened on either side of the breastplate. Chains depended from them to secure the helmet, sword, or misericorde.
- Maunche.* The heraldic sleeve, p. 112.
- Mentonnières.* Plate armour guarding the throat and chin, attached to the breastplate.
- Miniver.* A fur, see Vair.
- Misericorde.* The "dagger of mercy" worn by knights on the right hip, p. 200.
- Mitre.* Pp. 34, 38, 42, 94, 147.
- Morse.* The clasp or fastening of a cope, p. 147.
- Nebulé.* Pp. 85, 86.
- Orle.* The wreath or chaplet encircling the helmet of a knight.
- Orphrey.* Pp. 20-23.
- Palettes.* Also Pallets, protection for the armpits in steel or cuir-bouilli, p. 123.
- Pallium.* Pp. 33, 34.
- Pauldrons.* Pp. 202, 203.
- Paunce.* Plate armour for the body.
- Pelicon.* } A loose outer garment, full length and fur-lined.
Pelisse. }
- Petticoat.* Name given to the small coat worn under the longer coat or gown at the close of the fifteenth century, p. 189.
- Pilche.* A cloak or coat of fur.
- Pilion.* A round hat, fourteenth- and fifteenth-century term.
- Placcates* or *Placcards.* { Small steel plates used to strengthen the breastplate and (in the singular) also used to describe the stomacher worn by men and women at the close of fifteenth century, p. 189.
- Plate.* Armour of steel plates as opposed to "Mail," or armour composed of steel rings.
- Points.* The ties or laces used to fasten the different parts of costume together, p. 181.

- Poulaines.* Pp. 213, 214.
- Pourpoint.* P. 181.
- Quintise.* See Cointise.
- Quoif.* See Coif.
- Rerebrace.* Armour of plate for the upper arm, p. 123.
- Roskyn.* Squirrel fur.
- Sabbatons.* Pp. 186, 188, 189 and Plate VIII.
- Sable.* The fur next in value to Ermine and worn by Princes and Nobles.
- Samite.* Also Samit, a rich silk interwoven with gold.
- Sclavyn.* Also Sclavine and Esclavine, a pilgrim's mantle, p. 97.
- Sendall.* See Cendal.
- Siglatoun.* See Ciclatoun.
- Slops.* Wide breeches.
- Sollerets.* The overlapping plates forming the mailed shoe of a knight.
- Splints.* Overlapping plates defending the inside of the elbow.
- Standard-of-Mail.* A collar of mail to protect the neck, the collar of plate or gorget superceded it.
- Surcoat.* P. 44 and on numerous following pages.
- Super-côte-hardie.* Development of the surcoat, pp. 75, 108, 116, 168.
- Taces.* The skirt of plate from waist to mid-thigh.
- Tartarin.* A cloth of Tarsus, very fine and costly.
- Tassets.* See Taces.
- Tilting-helm.* A large helmet worn over the other at tournaments, pp. 100 and 124.
- Tippet.* 1. Pendant streamer from the hood or from the arm.
2. A shoulder-cape.
- Tuilles.* Similar to the Little Brayettes.
- Tunicle.* Pp. 21, 28.
- Turkils.* Turquoise.
- Vair.* Skin of the squirrel, dark on back, white on belly, made up in a pattern, usually in shield shapes.
- Vambraces.* Armour of plate for the lower arm, p. 123.

Vexillum. Pp. 146, 147.

Visor. Part of the helmet protecting the face pierced with slit or holes, moveable, usually pivoted at each side, p. 126.

Wambais. Also Wambeys, see Gambeson.

Weed. A single coat or cloak or the entire dress, example—"widow's weeds."

Wimple. A veil covering neck and chin, popular for women in the thirteenth century and afterwards survived in the dress of many of the Religious Orders, p. 40.

BIBLIOGRAPHY

IN the case of those volumes published in the first half of the nineteenth century, consultation is usually only possible in a large reference library; for this reason the names of later authorities who quote from the older authors are also given and as a rule these newer volumes are small in size and easily procured.

- BEAUMONT, E. T. *Academical Habit in Brasses*, 1928.
- BOCK, F. *Die Kleinodien des Heiligen Römischen Reiches Deutscher Nation*, 1864.
- BOUTELL, C. *A Manual of Heraldry*, revised, 1931.
- BOUTELL, C. *The Monumental Brasses of England*, 1849.
- BRAUN, P. *Die Liturgische Gewandung*, 1907.
- CHRISTIE, A. G. *English Medieval Embroideries*, 1938.
- GREENY, W. F. *Illustrations of Incised Slabs in the Continent of Europe*, 1891.
- DEMOTTE, *La Tapisserie Gothique*, 1921-1924.
- FAIRHOLT, F. W. *Costume of England* (revised by H. A. Dillon), 1896.
- FOX-DAVIES, A. C. *The Art of Heraldry*, 1904.
- FOX-DAVIES, A. C. *Heraldic Badges*, 1907.
- HAINES, H. *A Manual of Monumental Brass*, 1861.
- HOLLIS, T. and G. *Monumental Effigies of Great Britain*, 1840.
- HOTTENROTH. *Le Costume*, 1883-1892.
- HULME, F. E. *The History, Principles, and Practice of Heraldry*, 1892.
- JACQUEMIN. *Iconographie*, 1867.
- KENDRICK, A. F. *Catalogue of Textiles in the Victoria and Albert Museum*, 1925.
- KENDRICK, A. F. *English Embroidery*, 1904.

- LAKING, SIR GUY. *A Record of European Arms and Armour*, 1920-1922.
- MACALISTER, R. A. S. *Ecclesiastical Vestments*, 1896.
- MACKLIN, H. W. *The Brasses of England*, 1907.
- MEYRICK, SIR S. *A Critical Inquiry into Antient Armour*, 1824.
- PLANCHÉ, J. R. *History of British Costume*, revised edition, 1900 ;
and *Encyclopædia of Costume*, 1879.
- PUGIN, A. W. *Glossary of Ecclesiastical Ornament*, 1846.
- RACINET. *Le Costume*, 1888.
- ROCK, DR. *Textile Fabrics*, 1870.
- SHAW, H. *Dresses and Decorations of the Middle Ages*, 1843.
- STOTHARD, C. A. *Monumental Effigies of England*, 1817.
- STRUTT, J. *A Complete View of the Dresses and Habits of the People of England*, 1842.
- STRUTT, J. *Sports and Pastimes of the People of England*, 1833 (also 1903 edition).
- SUFFLING, E. R. *English Church Brasses*, 1910.
- TIRON, ABBÉ. *Histoire et Costume des Ordres Religieux*, 1848.
- VAN MARLE. *The Italian Schools of Painting*, 1924.
- VIOLLET-LE-DUC. *Dictionnaire Raisoné du Mobilier Français de l'Époque Carlovingienne à la Renaissance*, 1858.
- WALLER, J. G. and L. *A Series of Monumental Brasses*, 1842.
- WILLEMENT, T. *Regal Heraldry*, 1821.

MAGAZINES AND PUBLICATIONS

- Alcuin Club Collections, XXII., *The Ornaments of the Ministers as shown in Monumental Brasses*, by H. T. Clayton, 1919.
- Archæologia*, London Society of Antiquaries.
- Copenhagen, Møller Folkedraghter, 1916.
- Magazine of Fine Arts*, 1905-1906, "Sicilian and Italian Textiles," by A. F. Kendrick.