

Undergraduate Texts in Mathematics

UTM

J. David Logan

Applied Partial Differential Equations

Third Edition



Springer

Undergraduate Texts in Mathematics

Undergraduate Texts in Mathematics

Series editors

Sheldon Axler

San Francisco State University, San Francisco, CA, USA

Kenneth Ribet

University of California, Berkeley, CA, USA

Advisory Board

Colin Adams, *Williams College, Williamstown, MA, USA*

Alejandro Adem, *University of British Columbia, Vancouver, BC, Canada*

Ruth Charney, *Brandeis University, Waltham, MA, USA*

Irene M. Gamba, *The University of Texas at Austin, Austin, TX, USA*

Roger E. Howe, *Yale University, New Haven, CT, USA*

David Jerison, *Massachusetts Institute of Technology, Cambridge, MA, USA*

Jeffrey C. Lagarias, *University of Michigan, Ann Arbor, MI, USA*

Jill Pipher, *Brown University, Providence, RI, USA*

Fadil Santosa, *University of Minnesota, Minneapolis, MN, USA*

Amie Wilkinson, *University of Chicago, Chicago, IL, USA*

Undergraduate Texts in Mathematics are generally aimed at third- and fourth-year undergraduate mathematics students at North American universities. These texts strive to provide students and teachers with new perspectives and novel approaches. The books include motivation that guides the reader to an appreciation of interrelations among different aspects of the subject. They feature examples that illustrate key concepts as well as exercises that strengthen understanding.

For further volumes:

<http://www.springer.com/series/666>

J. David Logan

Applied Partial Differential Equations

Third Edition

 Springer

J. David Logan
Department of Mathematics
University of Nebraska-Lincoln
Lincoln, NE, USA

ISSN 0172-6056 ISSN 2197-5604 (electronic)
Undergraduate Texts in Mathematics
ISBN 978-3-319-12492-6 ISBN 978-3-319-12493-3 (eBook)
DOI 10.1007/978-3-319-12493-3
Springer Cham Heidelberg New York Dordrecht London

Library of Congress Control Number: 2014955188

Mathematics Subject Classification: 34-01, 00-01, 00A69, 97M50, 97M60

© Springer International Publishing Switzerland 2015

This work is subject to copyright. All rights are reserved by the Publisher, whether the whole or part of the material is concerned, specifically the rights of translation, reprinting, reuse of illustrations, recitation, broadcasting, reproduction on microfilms or in any other physical way, and transmission or information storage and retrieval, electronic adaptation, computer software, or by similar or dissimilar methodology now known or hereafter developed.

The use of general descriptive names, registered names, trademarks, service marks, etc. in this publication does not imply, even in the absence of a specific statement, that such names are exempt from the relevant protective laws and regulations and therefore free for general use.

The publisher, the authors and the editors are safe to assume that the advice and information in this book are believed to be true and accurate at the date of publication. Neither the publisher nor the authors or the editors give a warranty, express or implied, with respect to the material contained herein or for any errors or omissions that may have been made.

Printed on acid-free paper

Springer is part of Springer Science+Business Media (www.springer.com)

To Aaron, Rachel, and David

Contents

| | |
|--|-----|
| Preface to the Third Edition | ix |
| To Students | xi |
| 1. The Physical Origins of Partial Differential Equations | 1 |
| 1.1 PDE Models | 2 |
| 1.2 Conservation Laws | 12 |
| 1.3 Diffusion | 29 |
| 1.4 Diffusion and Randomness | 38 |
| 1.5 Vibrations and Acoustics | 49 |
| 1.6 Quantum Mechanics* | 57 |
| 1.7 Heat Conduction in Higher Dimensions | 60 |
| 1.8 Laplace's Equation | 66 |
| 1.9 Classification of PDEs | 72 |
| 2. Partial Differential Equations on Unbounded Domains | 79 |
| 2.1 Cauchy Problem for the Heat Equation | 79 |
| 2.2 Cauchy Problem for the Wave Equation | 87 |
| 2.3 Well-Posed Problems..... | 92 |
| 2.4 Semi-Infinite Domains..... | 96 |
| 2.5 Sources and Duhamel's Principle | 101 |
| 2.6 Laplace Transforms | 106 |
| 2.7 Fourier Transforms | 117 |
| 3. Orthogonal Expansions | 127 |
| 3.1 The Fourier Method | 127 |
| 3.2 Orthogonal Expansions..... | 131 |

| | | |
|---|--|------------|
| 3.3 | Classical Fourier Series | 145 |
| 4. | Partial Differential Equations on Bounded Domains | 155 |
| 4.1 | Overview of Separation of Variables | 156 |
| 4.2 | Sturm–Liouville Problems | 167 |
| 4.3 | Generalization and Singular Problems | 180 |
| 4.4 | Laplace’s Equation | 186 |
| 4.5 | Cooling of a Sphere | 198 |
| 4.6 | Diffusion in a Disk | 202 |
| 4.7 | Sources on Bounded Domains | 207 |
| 4.8 | Poisson’s Equation* | 216 |
| 5. | Applications in the Life Sciences | 229 |
| 5.1 | Age-Structured Models | 229 |
| 5.2 | Traveling Waves Fronts | 238 |
| 5.3 | Equilibria and Stability | 245 |
| 6. | Numerical Computation of Solutions | 257 |
| 6.1 | Finite Difference Approximations | 258 |
| 6.2 | Explicit Scheme for the Heat Equation | 260 |
| 6.3 | Laplace’s Equation | 268 |
| 6.4 | Implicit Scheme for the Heat Equation | 273 |
| Appendix A. Differential Equations | | 279 |
| References | | 285 |
| Index | | 287 |

Preface to the Third Edition

The goal of this new edition is the same as that for the original, namely, to present a one-semester treatment of the basic ideas encountered in partial differential equations (PDEs). The text is designed for a 3-credit semester course for undergraduate students in mathematics, science, and engineering. The prerequisites are calculus and ordinary differential equations. The text is intimately tied to applications in heat conduction, wave motion, biological systems, and a variety of other topics in pure and applied science. Therefore, students should have some interest, or experience, in basic science or engineering.

The main part of the text is the first four chapters, which cover the essential concepts. Specifically, they treat first- and second-order equations on bounded and unbounded domains and include transform methods (Laplace and Fourier), characteristic methods, and eigenfunction expansions (separation of variables); there is considerable material on the origin of PDEs in the natural sciences and engineering. Two additional chapters, Chapter 5 and Chapter 6, are short introductions to applications of PDEs in biology and to numerical computation of solutions. The text offers flexibility to instructors who, for example, may want to insert topics from biology or numerical methods at any time in the course. A brief appendix reviews techniques from ordinary differential equations. Sections marked with an asterisk (*) may safely be omitted. The mathematical ideas are strongly motivated by physical problems, and the exposition is presented in a concise style accessible to students in science and engineering. The emphasis is on motivation, methods, concepts, and interpretation rather than formal theory.

The level of exposition is slightly higher than students encounter in the post-calculus differential equations course. The philosophy is that a student should progress in the ability to read mathematics. Elementary texts contain

many examples and detailed calculations, but advanced mathematics and science books leave a lot to the reader. This text leaves some of the easy details to the reader. Often, the arguments are derivations in lieu of carefully constructed proofs. The exercises are at varying levels and encourage students to think about the concepts and derivations rather than just grind out lots of routine solutions. A student who reads this book carefully and who solves many of the exercises will have a sound knowledge base to continue with a second-year partial differential equations course where careful proofs are constructed or with upper-division courses in science and engineering where detailed, and often difficult, applications of partial differential equations are introduced.

This third edition, a substantial revision, contains many new and revised exercises, and some sections have been greatly expanded with more worked examples and additional explanatory material. A new, less dense, format makes key results more apparent and the text easier to read for undergraduates. The result is a text one-third longer. But the size and brevity of text, contrary to voluminous other texts, struck a chord with many users and that has been maintained. Many users provided suggestions that have become part of this revision, and I greatly appreciate their interest and comments.

Elizabeth Loew, my editor at Springer, deserves special recognition for her continuous and expert support. I have found Springer to be an extraordinary partner in this project.

Finally, this book is very affectionately dedicated to my two sons and daughter, Aaron, David, and Rachel, who have often been my teachers with their challenging and unique perspectives on life. For these gifts I greatly thank you.

I welcome suggestions, comments, and corrections. Contact information is on my web site: <http://www.math.unl.edu/~jlogan1>, where additional items can be found. Solutions to some of the exercises can be found on the Springer web site.

J. David Logan
Willa Cather Professor
Lincoln, Nebraska

To Students

Our understanding of the fundamental processes of the natural world is based to a large extent on partial differential equations. W. A. Strauss

Partial differential equations (PDEs) is a topic worthy of your study. It is a subject about differential equations involving unknown functions of several variables; the derivatives are partial derivatives. As such, it is a subject that is intimately connected with multivariable calculus. To be successful you should have a good command of the concepts in the calculus of several variables. So keep a calculus text nearby and review concepts when needed. The same comments apply to elementary ordinary differential equations (ODEs). An appendix at the end of the book reviews basic solution techniques for ODEs. If you wish to consult other sources, the texts by Farlow (1993) and Strauss (1994) are good choices.

A mathematics book must be read with a pencil and paper in hand. Elementary books fill in most steps in the exposition, but more advanced books leave many details to the reader. This book has enough detail so that you can follow the discussion, but pencil and paper work is required in some portions. Verifying all the statements and derivations in a text is a worthwhile endeavor and will help you learn the material. Many students find that studying PDEs provides an opportunity to hone their skills and reinforce concepts in calculus and differential equations. Further, studying PDEs increases your understanding of physical principles in a monumental way.

The exercises are the most important part of this text, and you should try to solve most of them. Some require routine analytical calculations, but others require careful thought. We learn mathematics by doing mathematics, even when we are stymied by a problem. The effort put into a failed attempt will help you sort out the concepts and reinforce the learning process. View the exercises as a challenge and resist the temptation to give up. It is also a good habit to write up your solutions in a clear, concise, logical form. *Good writing entails good thinking, and conversely.*

1

The Physical Origins of Partial Differential Equations

Many important ideas in mathematics are developed within the framework of physical science, and mathematical equations, especially partial differential equations, provides the language to formulate these ideas. In reverse, advances in mathematics provides the stimulus for new advancements in science. Over the years mathematicians and scientists extended these methodologies to include nearly all areas of science and technology, and a paradigm emerged called mathematical modeling. A *mathematical model* is an equation, or set of equations, whose solution describes the physical behavior of the related physical system. In this context we say, for example, that Maxwell's equations form a model for electromagnetic phenomena. Like most mathematical models, Maxwell's equations are based on physical observations. But the model is so accurate, we regard the model itself as describing an actual physical law. Other models, for example a model of how a disease spreads in a population, are more conceptual. Such models often explain observations, but only in a highly limited sense. In general, a mathematical model is a simplified description, or caricature, of reality expressed in mathematical terms. Mathematical modeling involves observation, selection of relevant physical variables, formulation of the equations, analysis of the equations and simulation, and, finally, validation of the model to ascertain whether indeed it is predictive. The subject of partial differential equations encompasses all types of models, from physical laws like Maxwell's equations in electrodynamics, to conceptual laws that describe the spread of an plant invasive species on a savanna.

1.1 PDE Models

In this book we examine models that can be described by partial differential equations. The focus is on the origin of such models and tools used for their analysis. Of particular interest are models in diffusion and heat flow, wave propagation, and transport of energy, chemicals, and other matter. It is impossible to overestimate the role and importance of PDEs in science and engineering.

Readers should be familiar with systems governed by ordinary differential equations (ODEs). For example, a typical ODE model in population ecology is the logistic model

$$\frac{du}{dt} = ru \left(1 - \frac{u}{K} \right), \quad t > 0,$$

which is a simple equation for population growth where the per capita rate of change of population, $u'(t)/u(t)$, is a decreasing function of the population. Here t is time, and $u = u(t)$ is the population of a given system of individuals. We refer to u as the state and say that the evolution of the state variable is governed by the model equation. The positive numbers r and K are given physical parameters that represent the relative growth rate and carrying capacity, respectively; presumably, r and K can be measured for the population under investigation. The solution to the logistic equation is easily found by separation of variables to be

$$u(t) = \frac{u_0 K}{u_0 + (K - u_0) e^{-rt}}, \quad t > 0,$$

where $u(0) = u_0$ is the initial population. The logistic model accurately describes some populations having a sigmoid growth shape. In general, an ODE model has the form

$$\frac{du}{dt} = F(t, u; r_1, \dots, r_n), \quad t > 0,$$

where F is a given functional relation between t , u , and m parameters r_1, \dots, r_m . Often the model includes an initial condition of the form $u(0) = u_0$, where u_0 is a given state value at $t = 0$. More generally, an ODE model may consist of a system of n ODEs for n state variables $u_1(t), \dots, u_n(t)$.

A PDE model differs from an ODE model in that the state variable u depends on more than one independent variable. ODEs govern the evolution of a system in time, and observations are made in time. PDEs model the evolution of a system in *both* time and space; the system can be observed both in a time interval and in a spatial region (which may be one-, two-, or three-dimensional). PDE models may also be independent of time, but depend on several spatial variables. Two examples of PDEs are

$$\begin{aligned} u_{tt}(x, t) - c^2 u_{xx}(x, t) &= 0, & (\text{wave equation}) \\ u_{xx}(x, y) + u_{yy}(x, y) &= 0. & (\text{Laplace's equation}) \end{aligned}$$

The wave equation describes the propagation of waves in a one dimensional medium. The unknown function $u = u(x, t)$ is a function of position x and time t . In Laplace's equation, the unknown state is a function $u = u(x, y)$, where x and y are spatial variables. It models, for example, equilibrium temperatures in a two-dimensional region of the plane with prescribed temperatures on its boundary.

Example 1.1

(Heat flow) Consider the problem of determining the temperature in a thin, laterally insulated, cylindrical, metal bar of length l and unit cross-sectional area, whose two ends are maintained at a constant zero degrees, and whose temperature initially (at time zero) varies along the bar and is given by a fixed function $\phi(x)$. See Figure 1.1.

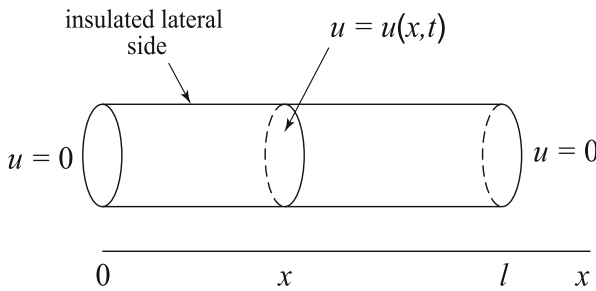

Figure 1.1 A laterally insulated metal bar with zero temperature at both ends. Heat flows in the axial, or x -direction, and $u(x, t)$ is the temperature of the cross-section at x at time t . At time $t = 0$ the temperature at locations x is given by $\phi(x)$

How does the bar cool down? In this case, the state variable u is the temperature, and it depends upon both when the measurement is taken and where in the bar it is taken. Thus, $u = u(x, t)$, where t is time and $0 < x < l$. The equation governing the evolution of the temperature u is called the **heat equation** (we derive it in Section 1.3), and it has the form

$$u_t = ku_{xx}. \quad (1.1)$$

Observe that the subscript notation is used to indicate partial differentiation, and we rarely write the independent variables, preferring u to $u(x, t)$. The equation states that the partial derivative of the temperature with respect to t must

equal the second partial derivative of the temperature with respect to x , multiplied by a constant k . The constant k , called the **diffusivity**, is a known parameter and a property of the bar; it can be determined in terms of the density, specific heat, and thermal conductivity of the metal. Values for these physical constants for different materials can be found in handbooks or online. Later we observe that (1.1) comes from a basic physical law (energy conservation) and an empirical observation (Fourier's heat conduction law). The conditions that the end faces of the bar are maintained at zero degrees can be expressed by the equations

$$u(0, t) = 0, \quad u(l, t) = 0, \quad t > 0, \quad (1.2)$$

which are called **boundary conditions** because they impose conditions on the temperature at the boundary of the spatial domain. The stipulation that the bar initially has a fixed temperature $\phi(x)$ degrees across its length is expressed mathematically by

$$u(x, 0) = \phi(x), \quad 0 < x < l. \quad (1.3)$$

This condition is called an **initial condition** because it specifies the state variable at time $t = 0$. The entire set of equations (1.1)–(1.3)—the PDE and the auxiliary conditions—form the mathematical model for heat flow in the bar. Such a model in the subject of PDEs is called an **initial boundary value problem**. The invention and analysis of such models are the subjects of this book. \square

In this heat flow model, the state variable u , the temperature, depends upon two independent variables, a time variable t and a spatial variable x . Such a model is an **evolution model**. Some physical systems do not depend upon time, but rather only upon spatial variables. Such models are called **steady state** or **equilibrium** models. For example, if Ω is a bounded, two-dimensional spatial domain representing a planar, laminar plate, and on the boundary of Ω , denoted by $\partial\Omega$, there is imposed a given, time-independent temperature, then the steady-state temperature distribution $u = u(x, y)$ inside Ω satisfies the Laplace equation, a partial differential equation having the form

$$u_{xx} + u_{yy} = 0, \quad (x, y) \in \Omega. \quad (1.4)$$

If we denote the fixed boundary temperature by $f(x, y)$, then (1.4) along with the boundary condition

$$u(x, y) = f(x, y), \quad (x, y) \in \partial\Omega, \quad (1.5)$$

is an equilibrium model for temperatures in the plate. In PDEs these spatial models are called **boundary value problems**. Solving Laplace's equation

(1.4) in a region Ω subject to a given condition (1.5) on the boundary is a famous problem called the **Dirichlet problem**.

In general, a second-order evolution PDE in one spatial variable and time is an equation of the form

$$G(x, t, u, u_x, u_t, u_{xx}, u_{tt}, u_{xt}) = 0, \quad x \in I, \quad t > 0, \quad (1.6)$$

where I is a given spatial interval, which may be a bounded or unbounded. The equation involves an unknown function $u = u(x, t)$, the state variable, and some of its partial derivatives. The **order** of a PDE equation is the order of the highest derivative that occurs. The PDE is almost always supplemented with initial and/or boundary conditions that specify the state u at time $t = 0$ and on the boundary. One or more parameters, which are not explicitly shown, may also occur in (1.6).

PDEs are classified according to their order and other properties. For example, as is the case for ODEs, they are classified as linear or nonlinear. Equation (1.6) is **linear** if G is a linear function in u and in all of its derivatives; how the independent variables x and t appear is not relevant. This means that the unknown u and its derivatives appear alone and to the first power. Otherwise, the PDE is **nonlinear**. A linear equation is **homogeneous** if every term contains u or some derivative of u . It is **nonhomogeneous** if there is a term depending only on the independent variables, t and x .

Example 1.2

Both second-order equations

$$u_t + uu_{xx} = 0 \quad \text{and} \quad u_{tt} - u_x + \sin u = 0$$

are nonlinear, the first because of the product uu_{xx} and the second because the unknown u is tied up in the nonlinear sine function. The second-order equation

$$u_t - \sin(x^2t)u_{xt} = 0$$

is linear and homogeneous, and the equation

$$u_t + 3xu_{xx} = tx^2$$

is linear and nonhomogeneous. \square

In many discussions it is convenient to introduce *operator notation*. For example, we can write the heat equation

$$u_t - ku_{xx} = 0$$

as

$$Lu = 0 \quad \text{where} \quad L = \frac{\partial}{\partial t} - k \frac{\partial^2}{\partial x^2}.$$

Here L is a differential operator, and we write its action on a function u as either Lu or $L(u)$. It acts on twice continuously differentiable functions $u = u(x, t)$ to produce a new function. We say a differential operator L is **linear** if, and only if, it satisfies the two conditions

$$L(u + v) = Lu + Lv, \quad L(cu) = cLu$$

for all functions u and v , and all constants c . If L is a linear, then the equation $Lu = 0$ is said to be **homogeneous**, and the equation $Lu = f$ is **nonhomogeneous**.

One cannot overstate the significance of the partition of PDEs into the two categories of linear and nonlinear. Linear equations have algebraic structure to their solution sets: *the sum of two solutions to a homogeneous linear equation is again a solution, as are constant multiples of solutions*. Another way of saying this is that solutions **superimpose**. Thus, if u_1, u_2, \dots, u_n are solutions to $Lu = 0$, and c_1, c_2, \dots, c_n are constants, then the **linear combination**

$$c_1 u_1 + c_2 u_2 + \dots + c_n u_n$$

is also a solution to $Lu = 0$. As we see later, this **superposition principle** extends in many cases to infinite sums and even to a continuum of solutions. For example, if $u(x, t, \xi)$ is a one-parameter family of solutions to $Lu = 0$, for all ξ in an interval J , then we can often prove

$$\int_J c(\xi) u(x, t, \xi) d\xi$$

is a solution to $Lu = 0$ for special conditions on the distributed ‘constants’ (i.e., the function) $c(\xi)$. These superposition principles are essential in this text. Every concept we use involves superposition in one way or another.

Another result based on linearity is that the real and imaginary parts of a complex-valued solution w to a homogeneous differential equation $Lw = 0$ are both real solutions. Specifically, if w is complex-valued function, then $w = u + iv$, where $u = \operatorname{Re} w$ and $v = \operatorname{Im} w$ are real-valued functions. Then, by linearity,

$$Lw = L(u + iv) = Lu + iLv = 0.$$

This implies $Lu = 0$ and $Lv = 0$, because if a complex function is identically zero then both its real and imaginary parts are zero.

Nonlinear equations do not share these properties. Nonlinear equations are harder to solve, and their solutions are more difficult to analyze. Even when

nature presents us with a nonlinear model, we often approximate it with a more manageable linear one.

Equally important in classifying PDEs is the specific nature of the physical phenomena that they describe. For example, a PDEs can be classified as *wave-like*, *diffusion-like*, or *equilibrium*, depending on whether it models wave propagation, a diffusion process, or an equilibrium state. For example, Laplace's equation (1.4) is a second-order, linear equilibrium equation; the heat equation (1.1) is a second-order, linear diffusion equation because heat flow is a diffusion process. In the last section of this chapter we give a more precise, mathematical characterization of these properties.

By a **solution** to the PDE (1.6) we mean a function $u = u(x, t)$ defined on the space-time domain $t > 0$, $x \in I$, that satisfies, upon substitution, the equation (1.6) identically on that domain. Implicit in this definition is the stipulation that u possess as many continuous partial derivatives as required by the PDE. For example, a solution to a second-order equation should have two continuous partial derivatives so that it makes sense to calculate the derivatives and substitute them into the equation. Whereas the general solution to an ODE involves arbitrary constants, the general solution to a PDE involves arbitrary functions. Sometimes the general solution to a PDE can be found, but it is usually not necessary to have it to solve most problems of interest.

Example 1.3

One should check, by direct substitution, that both functions

$$u_1(x, t) = x^2 + 2t \quad \text{and} \quad u_2(x, t) = e^{-t} \sin x$$

are solutions to the heat equation

$$u_t - u_{xx} = 0.$$

There are many other solutions to this equation. Auxiliary conditions, like initial and boundary conditions, generally single out the appropriate solution to a problem. \square

Example 1.4

Consider the first-order, linear, nonhomogeneous PDE

$$u_x = t \sin x.$$

This equation can be solved by direct integration. We integrate with respect to x , holding t fixed, to get

$$u(x, t) = -t \cos x + \psi(t),$$

where ψ is an arbitrary function of t . In PDEs, integration with respect to one variable produces an arbitrary function of the other variable, not an arbitrary constant as in one-dimensional calculus. This last equation defines the general solution. One can check that it is a solution for any differentiable function $\psi(t)$. Usually, PDEs have arbitrary functions in the expression for their general solutions; the number of such functions often agrees with the order of the equation. \square

Example 1.5

The second-order PDE for $u = u(x, t)$,

$$u_{tt} - 4u = 0$$

is just an like an ODE with x as a parameter. So the ‘constants’ depend on x . The solution is

$$u(x, t) = \phi(x)e^{-2t} + \psi(x)e^{2t},$$

where ϕ and ψ are arbitrary functions of x . \square

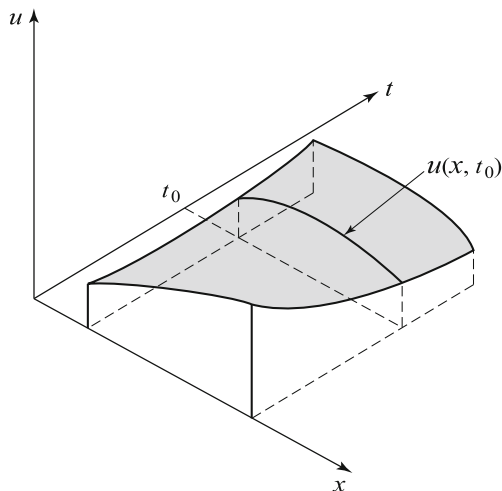

Figure 1.2 A solution surface $u = u(x, t)$. A cross-section $u(x, t_0)$ of the surface at time t_0 is interpreted as a wave profile at $t = t_0$

Geometrically, a solution $u = u(x, t)$ can be thought of as a *surface* in xtu -space. Refer to Figure 1.2. The surface lies over the space–time domain: $x \in I$, $t > 0$. Alternately, one could regard the solution as a continuous sequence of

time snapshots. That is, for each fixed time t_0 , $u(x, t_0)$ is a function of x alone and thus represents a time snapshot of the solution. In different words, $u(x, t_0)$ is the trace of the solution surface $u = u(x, t)$ taken in the $t = t_0$ -plane. In some contexts, $u(x, t_0)$ is interpreted as a *wave profile*, or signal, at time t_0 . In this way a solution $u(x, t)$ of (1.6) can be regarded a continuous sequence of evolving wave forms evolving in time.

Bibliographic Notes. There are dozens of excellent elementary PDE books written at about the same level as this one. We especially mention Farlow (1993) and Strauss (1992). A more advanced treatment is given by McOwen (2003). Nonlinear PDEs at the beginning level are treated in detail in Debnath (1997) or Logan (2008). PDE models occur in every area of the pure and applied sciences. General texts involving modeling in engineering and science are Lin & Segel (1989), Holmes (2011), and Logan (2013).

EXERCISES

1. Verify that a solution to the heat equation (1.1) on the domain $-\infty < x < \infty$, $t > 0$ is given by

$$u(x, t) = \frac{1}{\sqrt{4\pi kt}} e^{-x^2/4kt}.$$

For a fixed time, the reader should recognize this solution as a bell-shaped curve. (a) Pick $k = 0.5$. Use software to sketch several time snapshots on the same set of coordinate axes to show how the temperature profile evolves in time. (b) What do the temperature profiles look like as $t \rightarrow 0$? (c) Sketch the solution surface $u = u(x, t)$ in a domain $-2 \leq x \leq 2$, $0.1 < t < 4$. (d) How does changing the parameter k affect the solution?

2. Verify that $u(x, y) = \ln \sqrt{x^2 + y^2}$ satisfies the Laplace equation

$$u_{xx} + u_{yy} = 0$$

for all $(x, y) \neq (0, 0)$.

3. Find the general solution of the equation $u_{xy}(x, y) = 0$ in terms of two arbitrary functions.
4. Derive the solution $u = u(x, y) = axy + bx + cy + d$ (a, b, c, d constants), of the PDE

$$u_{xx}^2 + u_{yy}^2 = 0.$$

Observe that the solution does not explicitly contain arbitrary functions.

5. Find a function $u = u(x, t)$ that satisfies the PDE

$$u_{xx} = 0, \quad 0 < x < 1, \quad t > 0,$$

subject to the boundary conditions

$$u(0, t) = t^2, \quad u(1, t) = 1, \quad t > 0.$$

6. Verify that

$$u(x, t) = \frac{1}{2c} \int_{x-ct}^{x+ct} g(s) ds$$

is a solution to the wave equation $u_{tt} = c^2 u_{xx}$, where c is a constant and g is a given continuously differentiable function. Hint: Here you will need to use **Leibniz's rule** for differentiating an integral with respect to a parameter that occurs in the limits of integration:

$$\frac{d}{dt} \int_{a(t)}^{b(t)} F(s) ds = F(b(t))b'(t) - F(a(t))a'(t).$$

7. For what values of a and b is the function $u(x, t) = e^{at} \sin bx$ a solution to the heat equation

$$u_t = k u_{xx}.$$

8. Find the general solution to the equation $u_{xt} + 3u_x = 1$. Hint: Let $v = u_x$ and solve the resulting equation for v ; then find u .
9. Show that the nonlinear equation $u_t = u_x^2 + u_{xx}$ can be reduced to the heat equation (1.1) by changing the dependent variable to $w = e^u$.
10. Show that the function $u(x, y) = \arctan(y/x)$ satisfies the two-dimensional Laplace's equation $u_{xx} + u_{yy} = 0$.
11. Show that $e^{-\xi y} \sin(\xi x)$, $x \in \mathbb{R}$, $y > 0$, is a solution to $u_{xx} + u_{yy} = 0$ for any value of the parameter ξ . Deduce that

$$u(x, y) = \int_0^\infty c(\xi) e^{-\xi y} \sin(\xi x) d\xi$$

is a solution to the same equation for any function $c(\xi)$ that is bounded and continuous on $[0, \infty)$. Hint: The hypotheses on c allow you to bring a derivative under the integral sign. [This exercise shows that taking integrals of solutions sometimes gives another solution; integration is a way of superimposing, or adding, a continuum of solutions.]

12. Linear, homogeneous PDEs with constant coefficients admit complex solutions of the form

$$u(x, t) = Ae^{i(kx - \omega t)},$$

which are called **plane waves**. The real and imaginary parts of this complex function,

$$\operatorname{Re}(u) = A \cos(kx - \omega t), \quad \operatorname{Im}(u) = A \sin(kx - \omega t),$$

give real solutions. The constant A is the **amplitude**, k is the **wave number**, and ω is the **temporal frequency**. When the plane wave form is substituted into a PDE there results a **dispersion relation** of the form

$$\omega = \omega(k),$$

which states how the frequency depends upon the wave number. For the following PDEs find the dispersion relation and determine the resulting plane wave; sketch wave profiles at different times.

- a) $u_t = Du_{xx}$.
 - b) $u_{tt} = c^2 u_{xx}$.
 - c) $u_t + u_{xxx} = 0$.
 - d) $u_t = iu_{xx}$. (Here, i is the complex number $i^2 = -1$.)
 - e) $u_t + cu_x = 0$.
13. Second-order linear homogeneous equations with constant coefficients are often classified by their dispersion relation $\omega = \omega(k)$ (see Exercise 12). If $\omega(k)$ is complex, the PDE is called **diffusive**, and if $\omega(k)$ is real and $\omega''(k) \neq 0$, the PDE is called **dispersive**. The diffusion equation is diffusive; the wave equation is neither diffusive or dispersive. The term dispersive means that the speed $\omega(k)/k$ of a plane wave $u = Ae^{i(kx - \omega(k)t)}$ travels depends upon the wave number k . So waves of different wavelength travel at different speeds, and thus *disperse*. Classify the PDEs in (a)–(e) of Exercise 12 according to this scheme.
14. Find plane wave solutions to the Kuramoto–Sivashinsky equation

$$u_t = -u - \delta u_{xx} - u_{xxx}, \quad \delta > 0.$$

Find the dispersion relation and classify the equation according to the scheme of the preceding exercise. Describe the solutions and plot δ as a function of the wave number k to determine when the growth rate of a solution is zero. For which wave numbers will the solution decay?

1.2 Conservation Laws

Many PDEs come from a basic balance, or conservation law. A **conservation law** is a mathematical formulation of the fact that the rate at which a quantity changes in a given domain must equal the rate at which the quantity flows across the boundary (in minus out) plus the rate at which the quantity is created within the domain. For example, consider a population of a certain animal species in a fixed geographical region. The rate of change of the animal population must equal the rate at which animals migrate into the region, minus the rate at which they migrate out, plus the birth rate, minus the death rate. Such a statement is a verbal expression of a balance, or conservation, law. One can make similar kinds of statements for many quantities—energy, the mass of a chemical species, the number of automobiles on a freeway, and so on.

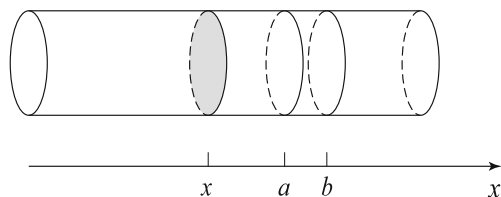

Figure 1.3 Tube with cross-sectional area A shown with arbitrary cross-section at x (*shaded*). The lateral sides are insulated, and the physical quantities vary only in the x -direction and in time. All quantities are constant over any cross-section

To quantify such statements we require some notation. Let the state variable $u = u(x, t)$ denote the density of a given quantity (mass, energy, animals, automobiles, etc.); density is usually measured in amount per unit volume, or sometimes amount per unit length. For example, energy density is measured in energy units per volume. We assume that any variation in the state be restricted to one spatial dimension. That is, we assume a one-dimensional domain (say, a tube, as in Figure 1.3 where each cross-section is labeled by the spatial variable x ; we require that there be no variation of $u(x, t)$ within the cross-section at x . Implicit is the assumption that the quantity in the tube is abundant and continuous enough in x so that it makes sense to define its density at each section of the tube. The amount of the quantity in a small section of width dx is $u(x, t)A dx$, where A is the cross-sectional area of the tube. Further, we let $\phi = \phi(x, t)$ denote the **flux** of the quantity at x , at time t . The flux measures the amount of the quantity crossing the section at x at time t , and its units are given in amount per unit area, per unit time. Thus, $A\phi(x, t)$ is the actual

amount of the quantity that is crossing the section at x at time t . By convention, flux is positive if the flow is to the right, and negative if the flow is to the left. Finally, let $f = f(x, t)$ denote the given rate at which the quantity is created, or destroyed, within the section at x at time t . The function f is called a **source term** if it is positive, and a **sink** if it is negative; it is measured in amount per unit volume per unit time. Thus, $f(x, t)A dx$ represents the amount of the quantity that is created in a small width dx per unit time.

A conservation law is a quantitative relation between u , ϕ , and f . We can formulate the law by considering a fixed, but arbitrary, section $a \leq x \leq b$ of the tube (Figure 1.3) and requiring that the rate of change of the total amount of the quantity in the section must equal the rate at which it flows in at $x = a$, minus the rate at which it flows out at $x = b$, plus the rate at which it is created within $a \leq x \leq b$. In mathematical symbols,

$$\frac{d}{dt} \int_a^b u(x, t) A dx = A\phi(a, t) - A\phi(b, t) + \int_a^b f(x, t) A dx. \quad (1.7)$$

This equation is the fundamental conservation law; it is an integral expression of the basic fact that there must be a balance between how much goes in, how much goes out, and how much is changed. Because A is constant, it may be canceled from the formula.

Equation (1.7) is an integral law. However, if the functions u and ϕ are sufficiently smooth, then it may be reformulated as a PDE, which is a local law. For example, if u has continuous first partial derivatives, then the time derivative on the left side of (1.7) may be brought under the integral sign to obtain

$$\frac{d}{dt} \int_a^b u(x, t) dx = \int_a^b u_t(x, t) dx.$$

If ϕ has continuous first partials, then the fundamental theorem of calculus can be applied to write the change in flux as the integral of a derivative, or

$$\phi(a, t) - \phi(b, t) = - \int_a^b \phi_x(x, t) dx.$$

Therefore, (1.7) may be written

$$\int_a^b (u_t(x, t) + \phi_x(x, t) - f(x, t)) dx = 0.$$

Because $a \leq x \leq b$ can be any interval whatsoever, and because the integrand is continuous, it follows that the integrand must vanish identically, or

$$u_t(x, t) + \phi_x(x, t) = f(x, t). \quad (1.8)$$

Equation (1.8) is a local version of (1.7), obtained under the assumption that u and ϕ are continuously differentiable; it is a PDE model describing the relation between the density the quantity, its flux, and the rate at which the quantity is created. We call the PDE (1.8) the **fundamental conservation law**. The f -term is called the source term, and the ϕ -term is called the flux term. In (1.8) we usually drop the understood notational dependence on x and t and just write $u_t + \phi_x = f$ for simplicity.

Before studying some examples, we make some general comments. The flux ϕ and source f are functions of x and t , but their dependence on x and t may be through dependence upon the density u itself. For example, the source term f may be given as a function of density via $f = f(u)$, where, of course, $u = u(x, t)$. Similarly, ϕ may depend on u . These dependencies lead to nonlinear models. Next, we observe that (1.8) is a single equation, yet there are two unknowns, u and ϕ (the form of the source f is assumed to be prescribed). This implies that another equation is required that relates u and ϕ . Such equations are called **constitutive relations** (or equations of state), and they arise from physical assumptions about the medium itself.

The Method of Characteristics

In this section, in the context of the advection of materials through a medium, we introduce the basic method for solving first order PDEs, the method of characteristics.

Example 1.6

(Advection) A model where the flux is proportional to the density itself, that is,

$$\phi = cu,$$

where c is a constant, is called an **advection** model. Notice that c must have velocity units (length per time). In this case the conservation law (1.8) becomes, in the absence of sources ($f = 0$),

$$u_t + cu_x = 0. \tag{1.9}$$

Equation (1.9) is called the **advection equation**. The reader should verify, using the chain rule, that the function

$$u(x, t) = F(x - ct) \tag{1.10}$$

is a solution to (1.9) for any differentiable function F . Such solutions (1.10) are called **right-traveling waves** because the graph of $F(x - ct)$ is the graph of $F(x)$ shifted to the right ct spatial units. So, as time t increases, the wave profile $F(x)$ moves to the right, undistorted, with its shape unchanged, at speed

c. Figure 1.4 shows two ways of viewing a right-traveling wave. Intuitively, (1.9) describes what we usually call advection. For example, a density cloud of smoke carried by the bulk motion of the wind would represent an advection process. Other common descriptive terms for this kind of movement are **transport** and **convection**. \square

Remark. The function $u(x, t) = F(z)$, $z = x - ct$, where F is an arbitrary function, is called the **general solution** of the advection equation $u_t + cu_x = 0$, $c > 0$. So the general solution is a right traveling wave. \square

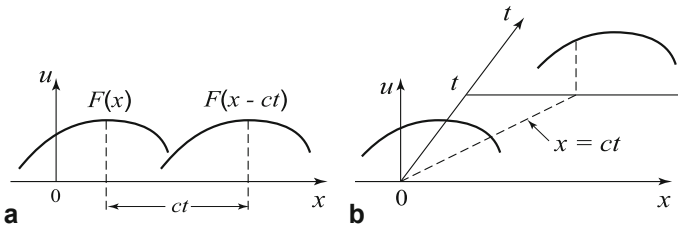

Figure 1.4 Two views of a traveling wave: (a) wave snapshots (*profiles*) at two different times, and (b) moving forward in space-time

Remark. If the flux is a nonlinear function of the density, that is, $\phi = \phi(u)$, then the conservation law (1.8) (again take $f = 0$) takes the form

$$u_t + \phi(u)_x = u_t + \phi'(u)u_x = 0. \quad (1.11)$$

If $\phi(u)$ is not linear in u , then (1.11) is a model of **nonlinear advection**, and such models are more difficult to analyze. Later in this section we examine simple nonlinear models. Logan (2008, 2013) can be consulted for an detailed treatment of nonlinear equations. \square

Example 1.7

(Advection and decay) Recall from elementary differential equations that decay (e.g., radioactive decay) is modeled by the law $du/dt = -\lambda u$, where λ is the decay rate. Thus, a substance advecting through a tube at positive velocity c (for example, a radioactive chemical dissolved in water flowing at speed c) is modeled by the advection–decay equation

$$u_t + cu_x = -\lambda u. \quad (1.12)$$

Here, $f = -\lambda u$ is the source term (specifically, the decay term) and $\phi = cu$ is the flux term in the conservation law (1.8). \square

Example 1.8

The pure initial value problem for the advection equation is

$$u_t + cu_x = 0, \quad x \in \mathbb{R}, t > 0, \quad (1.13)$$

$$u(x, 0) = u_0(x), \quad x \in \mathbb{R}, \quad (1.14)$$

where $u_0(x)$ is a given initial density, or signal. From (1.10) it follows that the solution to (1.13)–(1.14) is

$$u(x, t) = u_0(x - ct).$$

Physically, the initial density signal moves to the right at speed c . Alternatively, we think of the density signal moving along the family of parallel straight lines $\xi = x - ct = \text{constant}$ in space–time. These lines, called **characteristics**, are the curves that *carry the signal*. For the pure advection equation, the solution moves in such a way that the strength u of the density remains constant along any characteristic curve. \square

Now we solve a general advection equation of the form

$$u_t + cu_x + au = f(x, t), \quad (1.15)$$

where a and c are constants and f is a given function. Because the advection equation propagates signals at speed c , it is reasonable to transform this equation to a moving coordinate system. Thus, let ξ and τ be new independent variables, called **characteristic coordinates**, defined by

$$\xi = x - ct, \quad \tau = t.$$

We think of ξ as a moving coordinate that travels (or advects) with the signal. If we denote $u(x, t)$ in the new variables by $U(\xi, \tau)$ (that is, $U(\xi, \tau) = u(\xi + c\tau, \tau)$, or $u(x, t) = U(x - ct, t)$), then the chain rule gives

$$u_t = U_\xi \xi_t + U_\tau \tau_t = -cU_\xi + U_\tau$$

and

$$u_x = U_\xi \xi_x + U_\tau \tau_x = U_\xi.$$

So equation (1.15) becomes

$$U_\tau + aU = F(\xi, \tau),$$

where $F(\xi, \tau) = f(\xi + c\tau, \tau)$. This PDE contains derivatives with respect to only *one* of its independent variables and therefore can be regarded as an ODE with the other independent variable as a parameter. Thus it can be solved by ODE methods, which are reviewed in the Appendix. It has the form of a linear equation, and so it can be solved by multiplying by the integrating factor $e^{a\tau}$ and integrating with respect to τ . An example illustrates this procedure.

Example 1.9

Find the general solution of

$$u_t + 2u_x - u = t.$$

Let $\xi = x - 2t$, $\tau = t$. In these characteristic coordinates the equation becomes

$$U_\tau - U = \tau.$$

Multiplying by $e^{-\tau}$ gives

$$\frac{\partial}{\partial \tau}(Ue^{-\tau}) = \tau e^{-\tau}.$$

Integrating,

$$Ue^{-\tau} = \int \tau e^{-\tau} d\tau = -(1 + \tau)e^{-\tau} + g(\xi),$$

where g is an arbitrary function. Transforming back to xt variables then gives the general solution

$$u(x, t) = -(1 + t) + g(x - 2t)e^t. \quad \square$$

Remark. A more general reaction–advection PDE

$$u_t + cu_x = f(x, t, u),$$

where the source term depends on u , can in principle be solved by making the same transformation $\xi = x - ct$, $\tau = t$ to turn it into a simpler equation of the form

$$U_\tau = F(\xi, \tau, U).$$

In these characteristic coordinates the PDE simplifies to the form of an ODE with only one derivative. \square

The important point in the preceding discussion is that the advection operator $\frac{\partial}{\partial t} + c\frac{\partial}{\partial x}$ simplifies to $\frac{\partial}{\partial \tau}$ in characteristic coordinates; thus, changing independent variables is a strategy for handling equations having advection operators. This solution technique is called the **method of characteristics**.

A similar characteristic method can be applied to solve the equation

$$u_t + c(x, t)u_x = f(x, t, u).$$

In this case, we think of $c(x, t)$ as the advection speed in a heterogeneous medium; it replaces the constant c in the previous problem and now depends on the location in the medium and on time. The characteristic coordinates are given by $\xi = \xi(x, t)$, $\tau = t$, where $\xi(x, t) = C$ is the general solution of the ODE

$$\frac{dx}{dt} = c(x, t).$$

In these new coordinates we see that the original PDE transforms into an equation of the form

$$U_\tau = F(\xi, \tau, U),$$

where $U = U(\xi, \tau)$. (Verify this.) In theory this equation can be solved for U and then we can substitute for ξ and τ in terms of x and t to obtain $u = u(x, t)$.

Example 1.10

Consider the PDE

$$u_t + 2tu_x = 0.$$

Here, $c(x, t) = 2t$. Setting $\frac{dx}{dt} = 2t$ and solving gives $x - t^2 = C$. Thus, $\xi = x - t^2$. The characteristic coordinates are

$$\xi = x - t^2, \quad \tau = t,$$

and we find by the chain rule that

$$u_t = U_\xi(-2t) + U_\tau, \quad u_x = U_\xi.$$

Therefore $u_t + 2tu_x = U_\tau$ and the original PDE transforms into $U_\tau = 0$. Hence $U = g(\xi)$, where g is an arbitrary function. The general solution to the given PDE is thus $u(x, t) = g(x - t^2)$. Observe that the solution is constant along the set of characteristic curves (parabolas in space-time) $x - t^2 = C$. \square

Example 1.11

We solve the advection equation in the first quadrant with both initial and boundary conditions. Consider the equation

$$u_t + 2u_x = 0, \quad x > 0, \quad t > 0,$$

subject to the initial and boundary conditions

$$u(x, 0) = e^{-x}, \quad u(0, t) = (1 + t^2)^{-1}.$$

We know the general solution is $u(x, t) = F(x - 2t)$, where F is arbitrary. The idea is to let the PDE carry the boundary signals into the region; so

we determine the arbitrary function F separately in $x > 2t$ and in $x < 2t$. The separating characteristic $x = 2t$ is called the leading signal. For $x > 2t$, ahead of the leading signal, we apply the initial condition at $u(x, 0)$ because the characteristics in that region come from the x -axis:

$$u(x, 0) = F(x) = e^{-x}.$$

Then

$$u(x, t) = e^{-(x-2t)}, \quad x > 2t.$$

In the domain $0 < x < 2t$ we apply the boundary condition at $u(0, t)$ because the characteristics in that region come from the t -axis:

$$u(0, t) = F(-2t) = \frac{1}{1+t^2}.$$

To determine the form of F let $s = -2t$. Then $t = -s/2$ and

$$F(s) = \frac{1}{1+s^2/4}.$$

Therefore, the solution in $x < 2t$ is

$$u(x, t) = \frac{1}{1+(x-2t)^2/4}, \quad 0 \leq x < 2t.$$

Notice that the solution is continuous along the leading characteristic $x = 2t$, but the derivatives have discontinuities, giving a non-smooth solution. This phenomenon is common for first-order PDEs. Discontinuities are carried along the characteristics. \square

In Section 1.4 there is an expanded treatment of advection in a biological context.

Nonlinear Advection*

In the last few pages we studied two simple model advection equations, $u_t + cu_x = 0$ and $u_t + c(x, t)u_x = 0$. Both are first-order and linear. Now we study the same type of equation when a nonlinear flux $\phi(u)$ is introduced. Then the conservation law becomes

$$u_t + \phi(u)_x = 0.$$

Using the chain rule we find $\phi(u)_x = \phi'(u)u_x$. Denoting $c(u) = \phi'(u)$ gives, after appending an initial condition, the IVP

$$u_t + c(u)u_x = 0, \quad x \in \mathbb{R}, t > 0, \tag{1.16}$$

$$u(x, 0) = \phi(x), \quad x \in \mathbb{R}. \tag{1.17}$$

We think of u as a density and $c(u)$ as the speed that waves propagate. In many physical problems the speed that waves propagate increases with the density, so we assume for now that $c'(u) > 0$.

Consistent with the solution method for linear advection equations, we define the **characteristic curves** as integral curves of the differential equation

$$\frac{dx}{dt} = c(u). \quad (1.18)$$

Then along a particular characteristic curve $x = x(t)$ we have

$$\frac{du}{dt}(x(t), t) = u_x(x(t), t)c(u(x(t))) + u_t(x(t), t) = 0.$$

Therefore, like linear equations, u is constant along the characteristic curves. The characteristic curves are straight lines because

$$\frac{d^2x}{dt^2} = \frac{d}{dt} \left(\frac{dx}{dt} \right) = \frac{d}{dt} c(u(x(t))) = c'(u) \frac{du}{dt} = 0.$$

In the nonlinear case, however, the speed of the characteristic curves as defined by (1.18) depends on the value u of the solution at a given point. To find the equation of the characteristic C through (x, t) we note that its *speed* is

$$\frac{dx}{dt} = c(u(\xi, 0)) = c(\phi(\xi))$$

(see Figure 1.5). In the xt coordinate system, the speed of a signal is the reciprocal of its slope. This results from applying (1.18) at $(\xi, 0)$. Thus, after integrating, the characteristic curve is given by

$$x = c(\phi(\xi))t + \xi. \quad (1.19)$$

Equation (1.19) defines $\xi = \xi(x, t)$ implicitly as a function of x and t , and the solution $u(x, t)$ of the initial value problem (1.16) and (1.17) is given by

$$u(x, t) = \phi(\xi) \quad (1.20)$$

where ξ is defined by (1.19).

In summary, for the nonlinear advection equation (1.16):

- (a) Every characteristic curve is a straight line.
- (b) The solution u is constant on each such characteristic.
- (c) The speed of each characteristic, is equal to the value of $c(u)$ on that characteristic.
- (d) The speed $c(u)$ is the speed that signals, or waves, are propagated in the system.

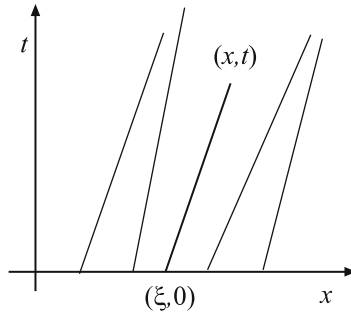

Figure 1.5 A diagram showing characteristics, or signals, moving at different speeds; each characteristic carries a constant value of u determined by its initial value at $t = 0$, at the point $(\xi, 0)$. The equation of the characteristic shown, from $(\xi, 0)$ to (x, t) , is given by (1.19). Its slope in the xt coordinate system is the inverse of its speed

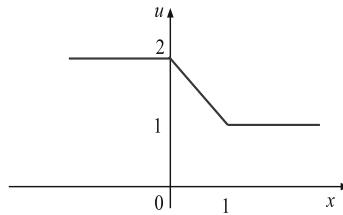

Figure 1.6 Initial wave profile in Example 1.12

Example 1.12

Consider the initial value problem

$$u_t + uu_x = 0, \quad x \in \mathbb{R}, \quad t > 0,$$

$$u(x, 0) = \phi(x) = \begin{cases} 2, & x < 0, \\ 2 - x, & 0 \leq x \leq 1, \\ 1, & x > 1. \end{cases}$$

The initial curve is sketched in Figure 1.6. Since $c(u) = u$ the characteristics are straight lines emanating from $(\xi, 0)$ with speed $c(\phi(\xi)) = \phi(\xi)$. These are plotted in Figure 1.7. For $x < 0$ the lines have speed 2; for $x > 1$ the lines have speed 1; for $0 \leq x \leq 1$ the lines have speed $2 - x$ and these all intersect at $(2, 1)$. Immediately one observes that a solution cannot exist for $t > 1$, because the characteristics cross at that time and they carry different constant values of

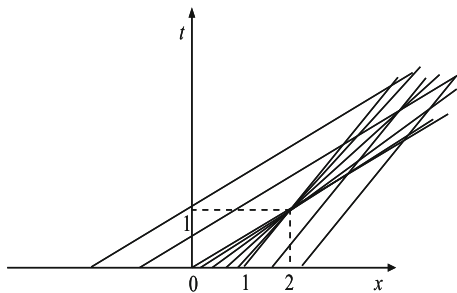

Figure 1.7 Characteristic diagram showing colliding characteristics

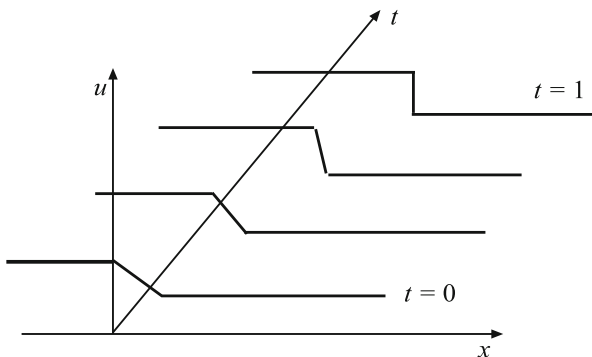

Figure 1.8 Solution surface with time profiles

u . Figure 1.8 shows several wave profiles that indicate steepening of the signal as it propagates. At $t = 1$ the wave *breaks*, which is the first instant when the solution would become multiple valued. To find the solution for $t < 1$ we note that $u(x, t) = 2$ for $x < 2t$ and $u(x, t) = 1$ for $x > t + 1$. For $2t < x < t + 1$ equation (1.19) becomes

$$x = (2 - \xi)t + \xi,$$

which gives

$$\xi = \frac{x - 2t}{1 - t}.$$

Equation (1.20) then yields

$$u(x, t) = \frac{2 - x}{1 - t}, \quad 2t < x < t + 1, \quad t < 1.$$

This explicit form of the solution also indicates the difficulty at the breaking time $t = 1$. \square

In general the initial value problem (1.16)–(1.17) may have a solution only up to a finite time t_b , which is called the **breaking time**. Let us assume in addition to $c'(u) > 0$ that the initial wave profile satisfies the conditions

$$\phi(x) \geq 0, \quad \phi'(x) < 0.$$

At the time when breaking occurs the gradient u_x will become infinite. To compute u_x we differentiate (1.19) implicitly with respect to x to obtain

$$\xi_x = \frac{1}{1 + c'(\phi(\xi))\phi'(\xi)t}.$$

Then from (1.20)

$$u_x = \frac{\phi'(\xi)}{1 + c'(\phi(\xi))\phi'(\xi)t}.$$

The gradient catastrophe will occur at the minimum value of t , which makes the denominator zero. Hence

$$t_b = \min_{\xi} \frac{-1}{\phi'(\xi)c'(\phi(\xi))}, \quad t_b \geq 0.$$

In the last example, $c(u) = u$ and $\phi(\xi) = 2 - \xi$. Hence $\phi'(\xi)c'(\phi(\xi)) = (-1)(1) = -1$ and $t_b = 1$ is the time when breaking occurs.

In summary we showed that the nonlinear partial differential equation

$$u_t + c(u)u_x = 0, \quad c'(u) > 0$$

propagates the initial wave profile at a speed $c(u)$, which depends on the value of the solution u at a given point. Since $c'(u) > 0$, large values of u are propagated faster than small values and distortion of the wave profile occurs. This is consistent with our earlier remarks. Wave distortion can occur and *shock waves*, or discontinuities, develop in materials because of the property of the medium to transmit signals more rapidly at higher levels of stress or pressure. Mathematically, distortion and the development of shocks or discontinuous solutions are distinctively nonlinear phenomena caused by the advection term $c(u)u_x$.

Example 1.13

(Implicit solution) When the advection speed is constant, we showed that

$$u_t + cu_x = 0$$

has general solution given explicitly by $u = F(x - ct)$, where F is an arbitrary function. A similar type implicit solution can occur for the nonlinear equation

$$u_t + c(u)u_x = 0.$$

In an exercise, the reader is asked to show, using the chain rule, that the expression

$$u = F(x - c(u)t),$$

defines the solution $u = u(x, t)$ implicitly, when it exists. The arbitrary function F is determined, for example, by an initial condition. \square

Example 1.14

Consider the PDE

$$u_t + u^2 u_x = 0.$$

The general solution is given implicitly by $u = F(x - u^2 t)$, which is easily verified. If $u(x, 0) = x$, then $F(x) = x$ and $u = x - u^2 t$. Solving for u gives

$$\begin{aligned} u &= \frac{1}{2t} (-1 \pm \sqrt{1 + 4tx}) \\ &= \frac{1}{2t} (-1 + \sqrt{1 + 4tx}), \end{aligned}$$

where we have taken the positive square root to meet the initial condition. The solution is valid for $t < -1/4x$. (See the Exercises.) \square

Example 1.15

(Traffic flow) Everyone who drives has experienced traffic issues, such as jams, poorly timed traffic lights, high road density, etc. In this abbreviated example we suggest how some of these issues can be understood with a simple model. Traffic moving in a single direction x with car density $\rho(x, t)$, given in cars per kilometer, can be modeled by a conservation law

$$\rho_t + (\rho v)_x = 0,$$

where $v = v(x, t)$ is the local car speed (kilometers per hour), and ρv is the flux, in cars per hour. Importantly, we are making a continuum assumption about cars, surely a questionable one. As always, we need a constitutive assumption to close the system. By experience, the speed of traffic surely depends on traffic density, or, $v = F(\rho)$. The simplest model is to assume that the flux ρv is zero when ρ is zero, and is jammed (no flux) when the density is some maximum value ρ_J . Therefore, we take

$$\rho v = \rho v_M \left(1 - \frac{\rho}{\rho_J} \right),$$

where v_M is the maximum velocity of cars. Note that this flux curve is a parabola, concave down. The conservation law can then be written after rescaling as

$$u_t + v_M[u(1-u)]_x = 0, \quad u = \frac{\rho}{\rho_M}.$$

This equation can be expanded to

$$u_t + v_M(1-2u)u_x = 0,$$

so $c(u) = v_M(1-2u)$ is the speed that traffic waves move in the system. It is different from the speed of cars! Because $c'(u) < 0$, signals are propagated backward into the traffic flow. This is reasonable. When you drive and a traffic density change occurs ahead of you (such a slowing down), that signal moves backward into the line of cars and eventually you are forced to slow down. \square

EXERCISES

1. How does the basic conservation law (1.8) change if the tube has variable cross-sectional area $A = A(x)$ rather than a constant cross-sectional area? (Assume that the variation in area is small over the interval.) Derive the formula

$$u_t + \phi_x = \frac{A'(x)}{A(x)}\phi.$$

2. Solve the initial value problem

$$u_t + cu_x = 0, \quad x \in \mathbb{R}, \quad t > 0; \quad u(x, 0) = e^{-x^2}, \quad x \in \mathbb{R}.$$

Pick $c = 2$ and sketch the solution surface and several time snapshots. Do you see a traveling wave? Sketch the characteristic curves in the xt -plane.

3. Find the general solution of the advection–decay equation (1.12) by transforming to characteristic coordinates $\xi = x - ct$, $\tau = t$.
4. Show that the decay term in the advection–decay equation (1.12) can be removed by making a change of the dependent variable to $w = ue^{\lambda t}$.
5. Solve the pure initial value problems in the region $x \in \mathbb{R}$, $t > 0$.

$$u_t + xt u_x = 0, \quad u(x, 0) = f(x)$$

and

$$u_t + xu_x = e^t, \quad u(x, 0) = f(x).$$

6. Solve the following initial value problems.

- a) $u_t + xu_x = -tu$, $x \in \mathbb{R}$, $t > 0$; $u(x, 0) = f(x)$, $x \in \mathbb{R}$.
- b) $tu_t + xu_x = -2u$, $x \in \mathbb{R}$, $t > 1$; $u(x, 1) = f(x)$, $x \in \mathbb{R}$.
- c) $u_t + u_x = -tu$, $x \in \mathbb{R}$, $t > 0$; $u(x, 0) = f(x)$, $x \in \mathbb{R}$.
- d) $2u_t + u_x = -2u$, $x, t \in \mathbb{R}$, $t > 0$; $u(x, t) = f(x, t)$ on the straight line $x = t$, where f is a given function .
- e) $tuu_t + xuu_x = -tx$, $x \in \mathbb{R}$, $t > 1$; $u(x, 1) = f(x)$, $x \in \mathbb{R}$.

7. Solve the initial boundary value problem

$$u_t + cu_x = -\lambda u, \quad x, t > 0,$$

$$u(x, 0) = 0, \quad x > 0, \quad u(0, t) = g(t), \quad t > 0.$$

In this problem treat the domains $x > ct$ and $x < ct$ differently as in Example 1.14; the boundary condition affects the solution region $x < ct$, and the initial condition affects it in the region $x > ct$.

8. Solve the pure initial value problem

$$u_t + u_x - 3u = t, \quad x \in \mathbb{R}, \quad t > 0,$$

$$u(x, 0) = x^2, \quad x \in \mathbb{R}.$$

9. To study the absorption of nutrients in an insect gut we model its digestive tract by a tube of length l and cross-sectional area A . Nutrients of concentration $n = n(x, t)$ flow through the tract at speed c , and they are adsorbed locally at a rate proportional to \sqrt{n} . What is the PDE model? If the tract is empty at $t = 0$ and then nutrients are introduced at the constant concentration n_0 at the mouth ($x = 0$) for $t > 0$, formulate an initial boundary value problem for $n = n(x, t)$. Solve this PDE model and sketch a graph of the nutrient concentration exiting the tract at $x = l$ for $t > 0$. Physically, explain why is the solution $n(x, t) = 0$ for $x > ct$.
10. Explain why the function $u(x, t) = G(x + ct)$, $c > 0$, is called a **left-traveling wave**. Explain how you would solve the advection equation $u_t - cu_x = F(x, t, u)$?
11. The density of cars on a busy one-lane freeway with no exits and entrances is $u = u(x, t)$ cars per mile. If $\phi = \phi(x, t)$ is the flux of cars, measured in cars per hour, derive a conservation law relating the density and flux. Why would $\phi = \alpha u(\beta - u)$ ($\alpha, \beta > 0$) be a reasonable assumption? Write down the resulting nonlinear PDE for u .

12. Find a formula that implicitly defines the solution $u = u(x, t)$ of the initial value problem for the reaction–advection equation

$$u_t + cu_x = -\frac{\alpha u}{\beta + u}, \quad x \in \mathbb{R}, t > 0,$$

$$u(x, 0) = f(x), \quad x \in \mathbb{R}.$$

Here, v, α , and β are positive constants. Show from the implicit formula that you can always solve for u in terms of x and t .

13. Write a formula for the general solution of the equation

$$u_t + cu_x = f(x)u.$$

Hint: Your answer should involve an integral with variable limits of integration.

14. Consider the Cauchy problem

$$u_t = xuu_x, \quad x \in \mathbb{R}, t > 0,$$

$$u(x, 0) = x, \quad x \in \mathbb{R}.$$

Find the characteristics, and find a formula that determines the solution $u = u(x, t)$ implicitly as a function of x and t . Does a smooth solution exist for all $t > 0$?

15. Consider the initial value problem

$$u_t + uu_x = 0, \quad x \in \mathbb{R}, t > 0,$$

$$u(x, 0) = \begin{cases} 1 - x^2, & |x| \leq 1, \\ 0, & |x| > 1. \end{cases}$$

Sketch the characteristic diagram. At what time t_b does the wave break? Find a formula for the solution.

16. Consider the initial value problem

$$u_t + uu_x = 0, \quad x \in \mathbb{R}, t > 0,$$

$$u(x, 0) = \exp(-x^2), \quad x \in \mathbb{R}.$$

Sketch the characteristic diagram and find the point (x_b, t_b) in space–time where the wave breaks.

17. Consider the Cauchy problem

$$u_t + c(u)u_x = 0, \quad x \in \mathbb{R}, t > 0,$$

$$u(x, 0) = f(x), \quad x \in \mathbb{R}.$$

Show that if the functions $c(u)$ and $f(x)$ are both nonincreasing or both nondecreasing, then no shocks develop for $t \geq 0$.

18. Consider the problem

$$\begin{aligned}u_t + u^2 u_x &= 0, & x \in \mathbb{R}, t > 0, \\u(x, 0) &= x, & x \in \mathbb{R}.\end{aligned}$$

Derive the solution

$$u(x, t) = \begin{cases} x, & t = 0, \\ \frac{\sqrt{1+4xt}-1}{2t}, & t \neq 0, 1+4tx > 0. \end{cases}$$

When do shocks develop? Verify that $\lim_{t \rightarrow 0^+} u(x, t) = x$.

19. Consider the **signaling problem**

$$\begin{aligned}u_t + c(u)u_x &= 0, & t > 0, x > 0, \\u(x, 0) &= u_0, & x > 0, \\u(0, t) &= g(t), & t > 0,\end{aligned}$$

where c and g are given functions and u_0 is a positive constant. If $c'(u) > 0$, under what conditions on the signal g will no shocks form? Determine the solution in this case in the domain $x > 0, t > 0$.

20. In the traffic flow model in Example 1.15, explain what occurs if the initial car density has each of the following shapes: (a) a density bump in the traffic having the shape of a bell-shaped curve; (b) a density dip in the traffic having the shape of an inverted bell-shaped curve; (c) a density that is jammed for $x < 0$, with no cars ahead for $x > 0$ (a stop light); (d) a density that is shaped like a curve $\pi/2 + \arctan x$ where the traffic ahead has increasing density.

In each case, sketch a qualitative characteristic diagram and sketch several density profiles. On the characteristic diagram sketch a sample car path.

21. The height $h = h(x, t)$ of a flood wave can be modeled by

$$h_t + (vh)_x = 0,$$

where v , the average stream velocity, is $v = a\sqrt{h}$, $a > 0$ (Chezy's law). Show that flood waves propagate 1.5 times faster than the average stream velocity.

22. Explain why the IVP

$$u_t + u_x = x, \quad x \in \mathbb{R}, \quad u(x, x) = 1, \quad x \in \mathbb{R},$$

has no solution.

23. Solve the PDE $u_t + u_x = 0$ with $u(\cos \theta, \sin \theta) = \theta$, $0 \leq \theta < 2\pi$.

1.3 Diffusion

The basic conservation law (1.8) with no sources is

$$u_t + \phi_x = 0. \quad (1.21)$$

To reiterate, $u = u(x, t)$ represents the density of a physical quantity, and $\phi = \phi(x, t)$ represents its flux. Equation (1.21) describes locally how changes in density are related to changes in flux. In the last section we modeled advection by assuming that the flux was proportional to the density (flux equals velocity times density, or $\phi = cu$). Now we want to model a simple diffusion process.

To fix the notion let u denote the concentration of some chemical species, say a gas, in a tube. We expect that the random motion and collisions of the molecules will cause concentrations of the gas to spread out; the gas will move from higher concentrations to lower concentrations. The same could be said for insects in a tube, people congregated in a hallway, or heat energy in a metal bar.

To model this type of motion, which is based on random collisions, we make two observations:

- (i) *the movement is from higher concentrations to lower concentrations.*
- (ii) *the steeper the concentration gradient, or the derivative, the greater the flux.*

Therefore, the flux should depend on the x -derivative of the density (which measures the steepness of the density curve). Assuming a simple linear relationship, we take

$$\phi = -Du_x, \quad (\text{Fick's law}) \quad (1.22)$$

where $D > 0$ is a constant of proportionality. The minus sign guarantees that if $u_x < 0$, then ϕ will be positive and the flow will be, by our convention, to the right; if $u_x > 0$, then ϕ will be negative and the flow will be to the left. We say that the flow is *down the gradient*. Equation (1.22) is called **Fick's law**, and the constant D is called the **diffusion constant**; D is measured in length-squared per unit time. (See Figure 1.9.)

When the constitutive equation (1.22) is substituted into the conservation law (1.21), we obtain a simple model equation

$$u_t - Du_{xx} = 0,$$

which is called the **diffusion equation**. This PDE model is one of the fundamental equations in applied mathematics, physics, engineering, and biology.

Geometrically, and physically, the diffusion equation states that if $u_{xx} > 0$ at a point, or the concentration profile is concave up, then $u_t > 0$, or the

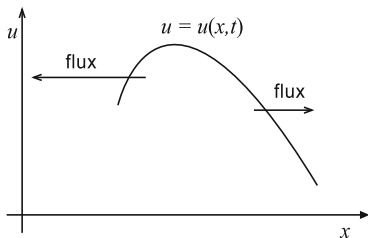

Figure 1.9 A time snapshot of a concentration profile $u(x, t)$. Diffusive motion is from higher concentrations to lower concentrations, or *down the gradient*. The magnitude of the flux is proportional to the slope

concentration increases at that point. Alternately, if the profile is concave down at a point, then $u_{xx} < 0$ and the concentration decreases, $u_t < 0$. Thus, there is a flattening effect. This is illustrated in Figure 1.10.

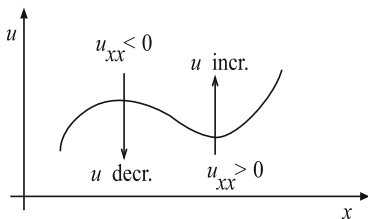

Figure 1.10 A time snapshot of a concentration profile $u(x, t)$. Where the profile is concave down, the concentration decreases; where it is concave up, it increases

Example 1.16

(Heat Conduction) Consider heat flow in a one-dimensional bar having a constant density ρ and constant specific heat C . Both of these constants are physical parameters that are tabulated in engineering and physics handbooks. The specific heat is the amount of energy required to raise a unit mass of material one degree, and it is given in units of energy per mass per degree. We may apply the basic conservation law (1.21) to the bar, with u being the energy density given by $u(x, t) = \rho C \theta(x, t)$, where $\theta = \theta(x, t)$ is the temperature at (x, t) (the stipulation that energy is proportional to temperature is, in itself,

an assumption about the medium). Therefore,

$$\rho C \theta_t + \phi_x = 0 \quad (1.23)$$

is an expression of energy balance in the bar when no sources are present. The energy flux ϕ is assumed to be given by a Fick's law-type expression

$$\phi = -K \theta_x, \quad (\text{Fourier's law}) \quad (1.24)$$

where K is thermal conductivity, another physical constant. In the context of heat flow, (1.24) is called the **Fourier heat law**. This law, a constitutive relation based on empirical evidence, is a statement of the fact that heat flows from hotter regions to colder regions; stated differently, *heat flows down the temperature gradient*. This statement is a manifestation of the second law of thermodynamics. Now, we may substitute (1.24) into (1.23) to obtain a single equation for the temperature $\theta(x, t)$, namely,

$$\theta_t - k \theta_{xx} = 0, \quad k \equiv \frac{K}{\rho C}. \quad (1.25)$$

Equation (1.25) is the **heat equation**; it is the diffusion equation in the context of heat flow. The constant k is called the **diffusivity** and is a property of the medium; values of k for different media (metals, plastics, etc.) can be found in physical handbooks. Note that k has the same dimensions (length-squared per time) as the diffusion constant D . In the sequel we shall often use u in place of θ for the temperature function. The physical interpretation is shown in Figure 1.10, where u is the temperature. \square

Example 1.17

(Time scale) Associated with a simple heat conduction problem is its characteristic time, or time scale, an easily computed number that roughly indicates how long it takes for heat to flow through a region. We could call this number a 'quick engineering estimate.' This quantity is found by noting the diffusivity k has units length-squared divided by time. Thus, if L is the length of a region and T is the *time for discernible temperature changes to occur*, then

$$\frac{L^2}{T} = k.$$

Thus $T = L^2/k$ is called the **time scale** for the problem. \square

In some cases the thermal conductivity K in (1.24) may not be constant, but rather may depend on x if the bar is nonhomogeneous; over large temperature ranges the conductivity also depends on the temperature θ . If, for example, $K = K(\theta)$, then we obtain a nonlinear heat model

$$\rho C \theta_t - (K(\theta) \theta_x)_x = 0.$$

It is possible, of course, that the density and specific heat could depend on the location x or the temperature θ . If C , ρ , or K depend on time, then the material is said to have *memory*.

Example 1.18

(Advection–Diffusion) If both diffusion and advection are present (think of smoke diffusing from a smokestack on a windy day), then the flux is given by

$$\phi = cu - Du_x,$$

and the conservation law (1.21) becomes

$$u_t + cu_x - Du_{xx} = 0,$$

which is the **advection–diffusion equation**. This equation would govern the density of a chemical, say, that is being advected by the bulk motion of a fluid moving at velocity c in which it is dissolved, while at the same time it is diffusing according to Fick's law. If the chemical also decays at rate λ , then we include a source term, and the model becomes

$$u_t + cu_x - Du_{xx} = -\lambda u,$$

which is a **advection–diffusion–decay equation**. \square

Example 1.19

(Contaminant flow in aquifers) Water resources is one of the most important issues that societies face. One example is how contaminants from chemical spills, etc., are carried through subsurface structures. Soil is a porous medium consisting of a fixed soil matrix interspersed with open pores through which groundwater flows. The fraction of water volume to total volume is ω , which is called the *porosity*. Simply, think of the medium as a long cylinder of cross-sectional area A . A solute, or contaminant, carried by the water, has concentration $C = C(x, t)$, which is the mass of the solute divided by the volume of the water. The conservation law for the solute states that the rate of change of the amount of solute in the interval equals its flux plus the rate S_t that the

solute is adsorbed, or desorbed, by the soil particles; the quantity $S = S(x, t)$ is the amount of the solute that is sorbed onto the soil particles:

$$\frac{d}{dt} \int_a^b \omega C A dx = A\phi(a, t) - A\phi(b, t) - \int_a^b \omega S_t A dx.$$

There are three sources of flux: advection, molecular diffusion, and kinematic dispersion. As before, *advection* is bulk motion due to the solute being carried by the water flow. Hydrogeologists measure the discharge q (volume of water per time) and the filtration, or *Darcy*, velocity $V = q/A$, the discharge per area. The advective flux is

$$\phi^{(a)} = qC = AVC.$$

Molecular diffusion is just the random motion of particles in still water and is measured by Fick's law, and *kinematic dispersion*, or spreading, is caused by the 'tortuous' motion through the winding porous pathways of the medium. These are given by, respectively,

$$\phi^{(\text{diff})} = -A\omega DC_x, \quad \phi^{(\text{disp})} = -A\omega D^{(d)}C_x,$$

where $D > 0$ is the diffusion constant and $D^{(d)}$ is the *dispersion coefficient*. The latter depends on the filtration velocity; for example, $D^{(d)} = \alpha |V|$. The total flux $A\phi$ is the sum of these three fluxes. Substituting these definitions into the conservation law and using the arbitrariness of the interval, we get in the usual way

$$C_t = (D + D^{(d)})C_{xx} - vC_x - S_t, \quad (1.26)$$

where $v = V/\omega$ is the *average velocity*. It is generally true that dispersion is much stronger than molecular diffusion, or $D^{(d)} \gg D$. Equation (1.26) is one of the most important equations in hydrogeology, and it is called the **reaction–advection–dispersion** equation. There are two unknowns in (1.26), the contaminant concentration C in the water and the amount S sorbed onto the soil. We should expect a constitutive relationship between the two. The simplest assumption is that there an equilibrium of the form $S = f(C)$, for example,

$$S = KC \quad \text{or} \quad S = \frac{\alpha C}{1 + \beta C}.$$

These relationships clearly lead to a single PDE for C . On the other hand, chemical kinetic relations of the form $S_t = F(C, S)$ model nonequilibrium processes. In this case there are coupled PDEs for C and S . The reader can consult Fetter (1993) or the monograph by Logan (2001). \square

Diffusion-like equations are generally accompanied by an *initial condition* that specifies the density at time $t = 0$ at all points of the spatial domain, as well as *boundary conditions* that specify conditions on the density at the boundaries of the domain for all time. This is especially true for heat conduction as well, the topic on which we focus. To fix the idea, consider a metal cylinder of finite length $0 \leq x \leq l$. Then an **initial condition** has the form

$$u(x, 0) = u_0(x), \quad 0 \leq x \leq l,$$

where u_0 is a prescribed initial temperature distribution over the length of the bar. There are three types of boundary conditions that usually arise in physical problems. If the temperature is specified at the boundary $x = 0$, for example, then we have

$$u(0, t) = g(t), \quad t > 0,$$

where g is a given function; this condition is called a **Dirichlet condition**. We could also specify the energy flux at a boundary, for example,

$$-Ku_x(0, t) = h(t), \quad t > 0,$$

which is called a **Neumann condition**. If $h(t) \equiv 0$, then we say that the boundary is **insulated**; heat cannot flow in or out. If g or h is zero, we also say that the corresponding boundary condition is **homogeneous**.

A third type of boundary condition has the form (say, at $x = 0$)

$$-Ku_x(0, t) = -\eta(u(0, t) - \psi(t)), \quad t > 0.$$

For heat flow in a bar, for example, this law expresses Newton's law of cooling, which states that the heat flux is proportional to the temperature difference between the end of the bar and a given temperature $\psi(t)$ of the environment; η is the constant of proportionality representing a heat-loss factor. These types of conditions are called **radiation**, or **Robin**, conditions.

The requirement of a **well-posed** problem is that the PDE be accompanied by appropriate initial and boundary conditions so that the resulting mathematical problem has a unique solution as well as a correct physical meaning.

Steady-State Solutions

Many PDE models have the property that after a long time the transients caused by initial conditions decay away and the solution approaches a **steady-state** $u = u(x)$, dependent only upon x . In this case the time-derivatives in the equation vanish and $u(x)$ satisfies an ODE with the appropriate boundary conditions. A simple example is given by the heat equation $u_t = ku_{xx}$. The steady-state solution $u = u(x)$ satisfies $ku''(x) = 0$, which, when solved, gives a linear temperature profile $u(x) = ax + b$. The constants a and b can be determined by the boundary conditions.

Example 1.20

Consider an initial boundary value problem for the diffusion-decay equation:

$$\begin{aligned}u_t &= Du_{xx} - ru, & 0 < x < L, & \quad t > 0, \\u(0, t) &= 0, & -Du_x(L, t) &= -1, & \quad t > 0, \\u(x, 0) &= g(x), & 0 < x < L.\end{aligned}$$

This model could, for example, represent a diffusing pollutant in a canal with per capita decay rate r . At the left boundary its density is maintained at zero, while at the right boundary the pollutant is introduced into the canal at rate 1 per unit area per unit time. The steady-state model is the pure boundary value problem

$$\begin{aligned}Du'' - ru &= 0, & 0 < x < L, \\u(0) &= 0, & -Du'(L) &= -1\end{aligned}$$

for $u = u(x)$. The initial condition is ignored because transients are assumed to have decayed away and longer affect the solution. To solve the differential equation we apply elementary methods (see the Appendix) to obtain

$$u(x) = c_1 \sinh(\sqrt{r/D} x) + c_2 \cosh(\sqrt{r/D} x),$$

where c_1 and c_2 are arbitrary constants. The boundary condition $u(0) = 0$ forces $c_2 = 0$, giving $u(x) = c_1 \sinh(\sqrt{r/D} x)$. The right boundary condition gives $-D\sqrt{r/D} c_1 \cosh(\sqrt{r/D} L) = -1$, or $c_1 = 1/\sqrt{rD} \cosh(\sqrt{r/D} L)$. Therefore the steady-state solution, representing the long time concentration in the canal, is

$$u(x) = \frac{\sinh(\sqrt{r/D} x)}{\sqrt{rD} \cosh(\sqrt{r/D} L)}. \quad \square$$

Pure boundary value problems for ODEs are unlike initial value problems in that they do not always have a solution, or they may have many solutions. Thus, there is no guarantee that the system has a steady-state solution. If there is a steady-state, it may be unstable and the system will not sustain it. These issues warrant further analysis, and they are discussed in Chapters 4 and 5.

EXERCISES

- Heat flows longitudinally through a laterally insulated metal bar of length 10 centimeters, and the temperature $u = u(x, t)$ satisfies the diffusion equation $u_t = ku_{xx}$, where $k = 0.02$ square centimeters per second. Suppose the temperatures at some fixed time T at $x = 4, 6, 8$ cm are 58, 64, and 72

degrees, respectively. Estimate $u_{xx}(6, T)$ using a difference approximation. Will the temperature at $x = 6$ increase or decrease in the next instant of time? Estimate the temperature at $x = 6$ at $T + 0.5$ seconds. Hint: Recall from calculus that

$$f''(a) \approx \frac{f(a-h) - 2f(a) + f(a+h)}{h^2},$$

where h is a small increment. This approximation is also derived in Chapter 6.

2. Let $u = u(x, t)$ satisfy the heat flow model

$$\begin{aligned} u_t &= ku_{xx}, & 0 < x < l, & t > 0, \\ u(0, t) &= u(l, t) = 0, & t > 0, \\ u(x, 0) &= u_0(x), & 0 \leq x \leq l. \end{aligned}$$

Show that

$$\int_0^l u(x, t)^2 dx \leq \int_0^l u_0(x)^2 dx, \quad t \geq 0.$$

Hint: Let $E(t) = \int_0^l u(x, t)^2 dx$ and show that $E'(t) \leq 0$. What can be said about $u(x, t)$ if $u_0(x) = 0$?

3. Show that the problem

$$\begin{aligned} u_t &= ku_{xx}, & 0 < x < l, & t > 0, \\ u(0, t) &= g(t), & u(l, t) &= h(t), & t > 0, \\ u(x, 0) &= u_0(x), & 0 \leq x \leq l, \end{aligned}$$

with nonhomogeneous boundary conditions can be transformed into a problem with homogeneous boundary conditions. Hint: Introduce a new dependent variable w via $w(x, t) = u(x, t) - L(x, t)$ by subtracting from u a linear function $L(x, t)$ of x that satisfies the boundary conditions at any fixed time t . In the transformed problem for w , observe that the PDE picks up a source term, so you are really trading boundary conditions for source terms.

4. Consider the heat flow problem

$$\begin{aligned} u_t &= ku_{xx} - hu, & 0 < x < 1, & t > 0, \\ u(0, t) &= u(1, t) = 1, & t > 0, \\ u(x, 0) &= g(x), & 0 \leq x \leq 1, \end{aligned}$$

where $k, h > 0$. Find the steady state solution and describe precisely where heat is flowing in this system.

5. Show that the advection–diffusion–decay equation

$$u_t = Du_{xx} - cu_x - \lambda u$$

can be transformed into the diffusion equation by a transformation of the form

$$u(x, t) = w(x, t)e^{\alpha x - \beta t}.$$

Solution: Take $\alpha = c/(2D)$, $\beta = \lambda + c^2/(4D)$.

6. Heat flow in a metal rod with a unit internal heat source is governed by the problem

$$\begin{aligned} u_t &= ku_{xx} + 1, & 0 < x < 1, & t > 0, \\ u(0, t) &= 0, & u(1, t) &= 1, & t > 0. \end{aligned}$$

What will be the steady–state temperature in the bar after a long time? Does it matter that no initial condition is given?

7. A bar loses heat across its lateral boundary at a rate proportional to the temperature u . The equation is

$$\begin{aligned} u_t &= ku_{xx} - au, & 0 < x < 1, & t > 0, \\ u(0, t) &= 1, & u(1, t) &= 1, & t > 0. \end{aligned}$$

Find and plot the steady–state temperature distribution in the bar and analyze how heat is flowing in the bar and through its boundaries.

8. Bacteria in a one-dimensional medium (a tube of unit cross-sectional area, length l , and capped on both ends) have a growth rate given by the logistic law $ru(1 - u/K)$, where r is the growth constant, K is the carrying capacity, and $u = u(x, t)$ is the density of bacteria measured in bacteria per unit length. Initially, the density is given by $u = ax(l - x)$. For $t > 0$ the bacteria also diffuse, with diffusion constant D . Formulate an initial boundary value problem for the density. Use intuition to sketch a sequence of density profiles showing how the density evolves in time. You may want to consider the cases $al^2 < 4K$ and $al^2 > 4K$ separately. Hint: Think about the problem if no diffusion were present.
9. Show that the equation $u_t = k(t)u_{xx}$ can be transformed into the diffusion equation by changing the independent variable time t to $\tau = \int_0^t k(\eta)d\eta$. Show that the equation $u_t = ku_{xx} - b(t)u_x$ can be transformed into the diffusion equation by changing the spatial variable to $\xi = x - \int_0^t b(\eta)d\eta$.

10. Burgers equation is a model for diffusion and nonlinear advection, and it is given by

$$u_t = Du_{xx} + uu_x.$$

What is the flux? Show that Burgers equation can be transformed into the diffusion equation $v_t = v_{xx}$ using the Cole–Hopf transformation $u = \psi_x$, $\psi = -2D \ln v$.

11. Derive the basic conservation law for diffusion with no sources if the cross-sectional area $A = A(x)$ of the tube is a function of x . Assume the diffusivity D is constant and $A(x)$ has on a small variation along the length of the tube.
12. A metal bar of constant cross-section and length l is composed of two different materials in perfect contact. In $0 \leq x < x_0$ the physical parameters are ρ_1, C_1, K_1 , and in $x_0 < x \leq l$ the physical parameters are ρ_2, C_2, K_2 . (a) At the contact point x_0 state specifically why the temperature and the flux must be continuous. (b) If the left end of the bar $x = 0$ is maintained at T_0 degrees, and the right end $x = l$ is maintained at T_l degrees, what is the steady state temperature in the bar?

1.4 Diffusion and Randomness

The notion of diffusion was introduced in Section 1.3, mostly in the context of heat conduction. In this section we investigate the connection between diffusion and random motion in general settings, including biological settings. Later, in Chapter 5, a broader treatment of life science models is offered.

In chemistry and physics it is easy to deduce, reasoning at an atomic or molecular level, how substances diffuse because of random motion. This microscopic description of diffusion is based on statistics and the fact that atoms or molecules collide randomly. These random collisions cause an assemblage of molecules to move from regions of high concentrations to regions of lower concentrations. For example, if a noxious gas is released at a point in a room, the colliding molecules of gas and the air lead to the eventual dispersion of the gas throughout the room. This stochastic, molecular model is the basis of the kinetic theory of gases, and it has a firm root in mathematics and in empirics. In chemically based biological systems where we are tracking molecular concentrations, we observe the same phenomenon. For example, a chemical, toxic to fish, might be dumped locally in a reservoir; the spread of the chemical throughout the reservoir can be understood by the molecular collision model.

In other biological systems, however, the same spreading effects are observed, but the cause is not random collisions on a microscopic scale, but interactions on a macroscopic scale. This effect is illustrated by the spread of an infectious disease. If infected individuals are introduced in a large population of susceptible individuals, then the infection can spread throughout the population by personal contact or by respiration of air born particulates. Even in clumped populations of organisms, there is a tendency for individuals to migrate from the high density regions to low density regions; this macroscopic dispersion is the result of population ‘pressures’ like competition for resources or might, in humans, even have some psychological basis. But the observation is the same as in the molecular collision model—movement from high to low densities.

To elaborate further, physical science models are usually based on scientific principles and laws that can be expressed precisely in terms of nearly exactly measurable quantities; the goal is to obtain precise quantitative results. For example, there is little question that Newton’s laws of motion or Maxwell’s equations of electrodynamics might apply to some physical situation. In some areas of the life sciences, however, it is really impossible to model all of the intricacies of predator-prey interactions, tumor growth dynamics, or the spread of an infectious disease. Therefore the models are more phenomenological in nature, predicting only qualitative features rather than leading to detailed quantitative results. Biological systems are highly complex, and often we attempt to describe only the gross features, ignoring much of the fine detail, the stochasticity, and the inherent variability.

We begin with a simple thought experiment that illustrates how diffusion and advection arise naturally in population dynamics. Imagine that we want to study the dynamics of a large population of organism in a one-dimensional linear domain length L . For example, we could equally focus on bacteria, cells, fish, or other organisms, and regard the linear domain as a canal or waterway. From elementary differential equations we recall that a population can be modeled by a growth law, or differential equation, for the population $u = u(t)$ of organisms at time t , uniformly over its spatial domain. Thus, u is actually a population *density*. When resources are limited and there is competition for those resources, and the population is often modeled by the logistic model

$$\frac{du(t)}{dt} = ru(t) \left(1 - \frac{u(t)}{K} \right),$$

where K is the carrying capacity and r is the intrinsic growth rate. The solution to this model equation is easily obtained by separation of variables, and it plots as the familiar sigmoid, or S-shaped, curve; the population $u(t)$ grows and approaches the environmental capacity K ; the growth rate approaches zero and growth is limited.

Clearly this model ignores how the organisms are distributed spatially in the domain. If we want to consider spatial distribution, then the population u will depend not only on time t but also upon the spatial variable x denoting its position in the domain, where $0 \leq x \leq L$; that is, $u = u(x, t)$. With this interpretation, $u(x, t)$ is a *local population density* measuring the number of organisms in a small volume $A\Delta x$ lying between x and $x + \Delta x$. In other words, $u(x, t)A\Delta x$ is the number of organisms in the small volume. Implicit in this model is that there are enough organisms in the domain so that defining a local density makes sense. To model population changes, we must ask how it evolves in both time and space; therefore we expect a PDE model for $u(x, t)$. If we adopt a growth model, then we must include terms (say, containing spatial partial derivatives) that indicate how the organisms move in the domain. For example, if the motion is due to diffusion, then the PDE model with logistic growth is, as may be expected,

$$u_t = Du_{xx} + ru \left(1 - \frac{u}{K}\right), \quad u = u(x, t).$$

This equation is called **Fisher's equation**, and it is one of the fundamental nonlinear PDEs of biology.

Knowledge of the population density $u(x, t)$ permits calculation of the total population in the domain at time t via

$$\text{Total population at time } t = \int_0^L u(x, t)A dx.$$

This discussion indicates how consideration of spatial structure leads to a PDE model. There are other types of structure besides spatial structure. If we are interested in the age of the organisms, then the age density depends upon the age a and time t ; hence, $u = u(a, t)$, where $u(a, t)\Delta a$ represents the number of individuals at time t between the ages a and $a + \Delta a$. An important exercise in life history theory is to develop models that predict the age structure $u(a, t)$ of a population at any time t if the initial age structure $u(a, 0)$ is known and the birth and death rates are given. These problems are discussed in Chapter 5. Other structured models might include other tags or labels like size or weight; these are called physiologically structured models. A population model that includes both age a and weight w leads to a PDE model for a function of three variables, $u = u(a, w, t)$. So the population density depends upon the organism's age, its length, and time. Other PDE models in the life sciences include models for biochemical reactions, transport of chemical species in the blood, models for tumor growth, and so on.

As in heat flow, there are two fundamental models in biology that describe transport, or motion: **advection** and **diffusion**. We encountered these processes in Sections 1.2 and 1.3. In the life sciences, advection refers to the

transport of particles, chemicals, animals, or whatever, via bulk motion of the supporting medium, e.g., wind, water, blood, and so on. Migration of a population is also advection. Diffusion refers to the random motion of particles, chemicals, animals, or whatever, that cause these entities to disperse from high densities to low densities, as discussed above. Figure 1.11 compares time profiles of both diffusion and advection processes, and a combination of the two.

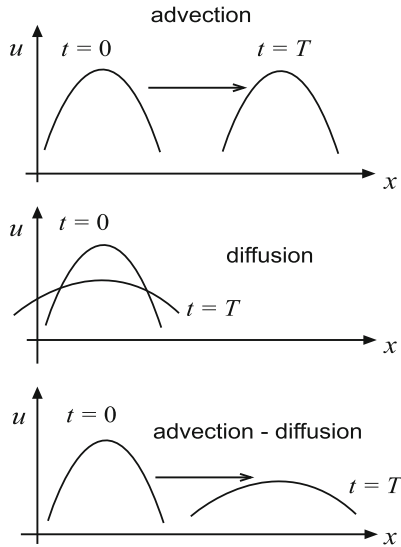

Figure 1.11 Spatial density profiles showing how an initial profile propagates in time under an advection, diffusion, and an advection–diffusion process

A model of advection follows from the conservation law derived in Section 1.2. To reiterate, the basic conservation law in one dimension relates the time derivative of the unknown density $u = u(x, t)$, the spatial derivative of the unknown flux $\phi = \phi(x, t)$, and the source (or sink) $f = f(x, t)$.¹ It is given by equation (1.8) as

$$u_t = -\phi_x + f. \quad (1.27)$$

The density can refer to density of animals, chemicals, or any particles or propagules. The flux, a measure of the flow rate, is usually dependent upon the density through the assumption of a constitutive equation; different motions

¹ Recall that the flux and source may depend on the density u as well.

arise from different assumptions. As we noted, advection is defined by the relation

$$\phi = cu,$$

where c is the bulk speed of the medium carrying the density, and diffusion is defined by Fick's law

$$\phi = -Du_x,$$

where D is the diffusion coefficient. The diffusion coefficient has dimensions of length-squared per time, and we often use the relation $D = L^2/T$ to estimate the time T that it takes for a substance to diffuse a length L . If c and D are constant, we can substitute these defining relations into (1.27), respectively, to obtain the fundamental balance equations:

$$u_t = -cu_x + f. \quad (\text{advection equation with source})$$

$$u_t = Du_{xx} + f. \quad (\text{diffusion equation with source})$$

If both advection and diffusion occur, then the flux is

$$\phi = -Du_x + cu,$$

and the fundamental balance law becomes

$$u_t = Du_{xx} - cu_x + f \quad (\text{advection-diffusion with a source})$$

Sources and sinks depend upon the model. For population models the source term f represents birth or growth rates, and a sink represents a death rate, either natural or by predation. For chemical problems, the source/sink term is called a reaction term and represents the rate that the chemical species is created or consumed by chemical reaction, or lost by absorption (say, across a cell boundary). Diffusion equations with source terms are usually called *reaction-diffusion equations*. Sources are positive terms, and sinks are negative terms. In addition, PDEs are always accompanied a relevant domain of space and time and by initial conditions and/or boundary conditions; an initial condition prescribes the initial density distribution $u(x, 0)$, and a boundary condition prescribes what is going on at the boundary of the domain. In the latter case we may specify the density u itself (a Dirichlet condition), or we may specify the flux ϕ (a Neumann condition). It is important to notice that the flux has a different form for the three models defined above: advection, diffusion, and advection-diffusion.

In some biological processes the advection speed c and the diffusion constant may depend upon location in the medium, and thus depend upon x , or they may depend upon the density u itself. That is, $c = c(x, u)$ and $D = D(x, u)$.

Dependence upon x signifies a heterogeneous medium of propagation. Therefore, the advection-diffusion equation with a source is

$$u_t = (Du_x)_x - (cu)_x + f,$$

and the c and D factors may not be pulled out of the spatial derivatives. When c or D depends upon u , the equation is nonlinear. The source term f can also introduce nonlinearities.

Random Motion

Now we want to show how this diffusion model arises from a stochastic argument based upon random motion. Let X be a random variable with a normal probability density function (the “bell-shaped curve”)

$$N(x, \mu, \sigma) = \frac{1}{\sqrt{2\pi\sigma^2}} e^{-(x-\mu)^2/2\sigma^2},$$

where μ is the mean, or center of the density, and σ is the standard deviation, a measure of the spread about the mean. By definition, the area under the normal curve, $\int_a^b N(x, \mu, \sigma) dx$, is the probability of X taking a value between a and b . Amazingly enough, if we take the standard deviation to depend upon time via $\sigma = \sqrt{2Dt}$, so that the spread of the data gets larger with time, then we obtain the function

$$u(x, t) = \frac{1}{\sqrt{4\pi Dt}} e^{-(x-\mu)^2/4Dt},$$

which is a solution to the diffusion equation! This formula gives the solution to the diffusion equation generated by a unit point source given initially at $x = \mu$, and it is called the **fundamental solution** to the diffusion equation, or the **point-source solution**. That is, the fundamental solution is the formula for the time-changing, spreading density distribution of a substance caused by placing a unit amount of the substance at $x = \mu$ at time $t = 0$.

It is not an accident that there is such a close relationship between the diffusion equation and probabilities. We look in a different direction to affirm this relationship.

Let x represent an arbitrary point on the x -axis. Now divide the axis into equal segments of length h so that the entire axis is composed of segments with discrete endpoints $\dots, x - 2h, x - h, x, x + h, x + 2h, \dots$. Let $u = u(x, t)h$ be the number of particles (e.g., cells, organisms, molecules) in the interval $(x, x + h)$ at time t . Figure 1.12 is a schematic of a typical histogram showing the distribution of the assemblage of particles at time t . Now assume in the next small instant of time τ that *all* the particles in each interval move randomly

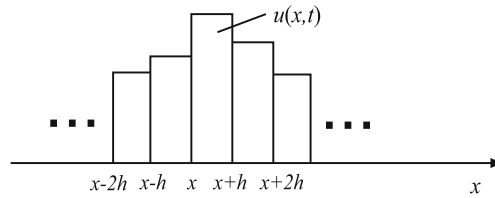

Figure 1.12 Histogram where $u(x, t)h$ represents the number of particles in the interval $(x, x + h)$ at time t

to the right or to the left with an equal probability of one-half. Then we can calculate the particle distribution at the next time $t + \tau$. We get

$$\begin{aligned}
 & \text{Change in number of particles in } (x, x + h) \\
 = & \text{ number that move in from the left} \\
 & + \text{ number that move in from the right} \\
 & - \text{ number that leave to the left} \\
 & - \text{ number that leave to the right.}
 \end{aligned}$$

Here, by ‘number’ we mean ‘average number’. In symbols, after cancelling the common factor h ,

$$u(x, t + \tau) - u(x, t) = \frac{1}{2}u(x - h, t) + \frac{1}{2}u(x + h, t) - \frac{1}{2}u(x, t) - \frac{1}{2}u(x, t).$$

This simplifies to

$$u(x, t + \tau) = \frac{1}{2}u(x - h, t) + \frac{1}{2}u(x + h, t).$$

This is a difference equation relating the number of particles in three adjacent intervals at two different times. Because h and τ are small, we may expand the three terms of this equation in Taylor series to obtain

$$\begin{aligned}
 u(x, t) + u_t(x, t)\tau + O(\tau^2) &= \frac{1}{2} \left(u(x, t) - u_x(x, t)h + \frac{1}{2}u_{xx}(x, t)h^2 + O(h^3) \right) \\
 &+ \frac{1}{2} \left(u(x, t) + u_x(x, t)h + \frac{1}{2}u_{xx}(x, t)h^2 + O(h^3) \right),
 \end{aligned}$$

where $O(\tau^2)$ denotes remaining terms of the series, all of which have a factor of at least τ^2 , and $O(h^3)$ denotes remaining terms which have a factor of at least h^3 .² Simplifying gives

² Terms like $O(h^3)$ are called *order* terms and we read such terms as *an order h^3 term*. Precisely, an expression $G(h)$ is order h^α for small h if $G(h)/h^\alpha$ remains bounded for all h sufficiently small, $h \neq 0$.

$$u_t(x, t) = \frac{h^2}{2\tau} u_{xx}(x, t) + O(\tau) + \frac{1}{\tau} O(h^3).$$

Now we take the limit as $\tau \rightarrow 0$ and $h \rightarrow 0$ in such a way that we maintain the ratio $\frac{h^2}{2\tau}$ equal to a fixed constant D . Therefore, in this special limit, we obtain

$$u_t(x, t) = Du_{xx}(x, t),$$

which is the diffusion equation. (An exercise requests this same derivation when the probability of moving right or left is p and $1 - p$, respectively. One obtains the diffusion equation with *drift*, i.e., the advection-diffusion equation). A detailed discussion of the connection between diffusion and random motion can be found in Murray (2003).

Point-Source Solutions

Point-source solutions to linear diffusion equations play a special role in both applications and theory of PDEs, and so we make a few further comments and catalog some other such solutions. A point-source solution are also called **fundamental solutions**, and those that also satisfy given boundary conditions are called **Green's functions**. As we observe later in Chapter 2, knowledge of the Green's function for a PDE allows us to solve the PDE with an arbitrary nonhomogeneous, or source term, by simple superposition. This theme appears throughout the book.

For the present however, we only illustrate some fundamental solutions to the basic diffusion-type equations we encountered so far. In one-dimensional linear geometry we repeat our basic result. The fundamental solution to the diffusion equation

$$u_t = Du_{xx}, \quad x \in \mathbb{R}, t > 0, \quad (1.28)$$

is

$$u = G(x, \mu, t) = \frac{1}{\sqrt{4\pi Dt}} e^{-(x-\mu)^2/4Dt}. \quad (1.29)$$

In an advection-diffusion or growth-diffusion process is present, we can also obtain special solutions that represent the density distribution arising from an initial, unit point source at $x = \mu$. For the **advection-diffusion** equation

$$u_t = Du_{xx} - cu_x, \quad x \in \mathbb{R}, t > 0, \quad (1.30)$$

the fundamental solution is

$$u = G(x - ct, \mu, t) = \frac{1}{\sqrt{4\pi Dt}} e^{-(x-\mu-ct)^2/4Dt}, \quad (1.31)$$

while for the **growth-diffusion** equation

$$u_t = Du_{xx} + \gamma u, \quad x \in \mathbb{R}, t > 0, \quad (1.32)$$

the fundamental solution is

$$u = e^{\gamma t} G(x, \mu, t) = \frac{1}{\sqrt{4\pi Dt}} e^{-(x-\mu)^2/4Dt + \gamma t}. \quad (1.33)$$

Here is an example of an application in biology.

Example 1.21

(Invasion speed) Consider a very long canal with still water where a non-indigenous species of algae is accidentally released at the point $x = 0$. After a long period of time it is observed that the speed of the biological invasion outward in both directions from $x = 0$ is nearly constant. We show that this observation can be explained by a diffusion-growth model. The point-source solution to diffusion-growth model is given above. Let $x = x_f(t)$ denote the position of the wavefront, defined by the position where the population density is $u = u_f$, where u_f is a small, given value of the density. Then, from the fundamental solution

$$\frac{1}{\sqrt{4\pi Dt}} e^{-x_f(t)^2/4Dt + \gamma t} = u_f.$$

Taking logarithms gives

$$\gamma t - \frac{x_f(t)^2}{4Dt} = \ln(\sqrt{4\pi Dt} u_f).$$

Now we make a clever approximation. For large times t the right side gets large, but not as large as the γt term (recall that t is much larger than $\ln t$). Therefore, the only two terms in this equation that can balance for large t are the two on the left side. Thus the long time, approximate position of the invasion front is

$$x_f(t) \approx \sqrt{4\gamma D t}.$$

Consequently, the speed of the front approaches a constant value $\sqrt{4\gamma D}$. \square

The diffusion equation in two dimensions with **radial symmetry**, where the density $u = u(r, t)$ depends only of the distance r from the origin and time, is (see Exercise 12)

$$u_t = D \frac{1}{r} (ru_r)_r. \quad (1.34)$$

The fundamental solution, with the unit source at the origin,

$$u(r, t) = \frac{1}{4\pi Dt} e^{-r^2/4Dt}$$

In three dimensions, the diffusion equation with **spherical symmetry**, where $u = u(\rho, t)$ depends only upon the distance ρ from the origin and time, is

$$u_t = D \frac{1}{\rho^2} (\rho^2 u_\rho)_\rho. \quad (1.35)$$

In this case the point-source solution is, with the unit source at the origin,

$$u(\rho, t) = \frac{1}{(4\pi Dt)^{3/2}} e^{-\rho^2/4Dt}.$$

A major difference between point-source solutions in linear, radial, and spherical symmetry is the decaying, time-dependent amplitude factor appearing in front of the exponential term; the decay factors are $1/\sqrt{t}$, $1/t$, and $1/t^{3/2}$, respectively.

EXERCISES

1. In Fick's law assume the diffusion coefficient D is a function of the density u , i.e., $D = D(u)$. Show that the diffusion equation without sources can be written

$$u_t = D(u)u_{xx} + D'(u)u_x^2.$$

2. From the diffusion equation with no sources, find the steady-state concentration $u = u(x)$ of a chemical in a tube of length $L = 2$ with diffusion coefficient D and subject to boundary conditions $u(0) = 4$ and $u'(2) = 1$. Explain these conditions in terms of chemical concentrations and fluxes. Under the same boundary conditions, what is the steady-state concentration if D depends on x , e.g., $D = (1 + x)^{-1}$? What is the steady state solution if D depends on u , e.g., $D = u$?
3. Considering all cases, find the form of steady-state, or time-independent, solutions to the advection-diffusion equation

$$u_t = Du_{xx} - cu_x$$

and the advection-diffusion-growth equation

$$u_t = Du_{xx} - cu_x + ru.$$

4. An environmentally toxic radioactive chemical is continually released at a constant rate of 1 (mg per vol per time) at the midpoint of a canal of length L with still water. As it diffuses through the canal with diffusion constant $D = 1$, it decays at rate λ (per unit time) The ends of the canal are connected to large bodies of toxic-free water. Set up the model equations and

the boundary conditions. Find the steady-state concentration and sketch its spatial profile for different values of L and λ . Hint: Break the problem up into two parts, on each side of the source. At the source the concentration must be continuous, and in a small interval about the source, the ‘flux in’ minus the ‘flux out’ equals one.

5. Work the preceding problem if there is no decay and if the source is located at $x = \xi$, $0 < \xi < L$.
6. Consider the advection-diffusion equation on an interval $0 < x < L$. Show that if the flux at $x = 0$ equals the flux at $x = L$, then the density is constant.
7. The population density of zooplankton in a deep lake varies as a function of depth $x > 0$ and time t ($x = 0$ is the surface). Zooplankton diffuse vertically with diffusion constant D and buoyancy effects cause them to migrate toward the surface with an advection speed of αg , where g is the acceleration due to gravity. Ignore birth and death rates. Find a PDE model for the population density of zooplankton in the lake, along with the appropriate boundary conditions at $x = 0$ and $x = +\infty$. Find the steady-state population density for zooplankton as a function of depth, and sketch its graph. Note that the flux is advective and diffusive.
8. Sucrose in water has a diffusion coefficient of 4.6×10^{-6} cm²/sec. Estimate how far a concentrated amount of sucrose would diffuse in 1 day? A certain insect pheromone diffuses in air with diffusion constant 2.0×10^{-1} cm²/sec. Estimate the time it takes for the pheromone to diffuse a distance of 100 m. Can diffusion alone account for sexual attraction of mates for this insect?
9. Show that the steady-state solutions to the diffusion equation in linear geometry, in planar geometry with radial symmetry, and in spatial geometry with spherical symmetry are, respectively,

$$u = ax + b,$$

$$u = a \ln r + b,$$

$$u = \frac{a}{\rho} + b.$$

Here, a and b are arbitrary constants.

10. Repeat the random walk derivation in this section in the case that the probability of moving right or left is p and $1 - p$, respectively, rather than one-half in either direction. Show that under appropriate limit definitions as $h \rightarrow 0$ and $\tau \rightarrow 0$, one obtains the advection-diffusion equation.

11. Muskrats were accidentally introduced in Europe in 1905 and the biological invasion spread approximately radially in all directions. Let u_f define a predetermined magnitude of the population density on a circle of radius $r = r_f(t)$ as the front spreads. Use a diffusion-growth model to show that the speed of the wave front is approximately constant for large times t .
12. (a) Derive the radially symmetric diffusion equation

$$u_t = D \frac{1}{r} (ru_r)_r$$

from basic principles using the following strategy. Take two circles of radius $r = a$ and $r = b$ and write down the conservation law in polar coordinates for the density in the annular region in between (recall that an area element in polar coordinates is $rdrd\theta$ and that the radial flux is $-Du_r$). (b) Do the same for spherically symmetric diffusion

$$u_t = D \frac{1}{\rho^2} (\rho^2 u_\rho)_\rho$$

by considering two concentric spheres.

1.5 Vibrations and Acoustics

Wave motion is one of the most commonly occurring phenomenon in nature. We mention electromagnetic waves, water waves, sound and acoustic waves, and stress waves in solids as typical examples. In this section we begin with a simple model to introduce the concept of wave motion and one of the fundamental PDEs, the wave equation, that describe such phenomena. The example is the small, transverse vibrations of a flexible, elastic string, e.g., a guitar string. Then we discuss wave motion in the context of acoustics.

Vibrations of a String

Let us imagine a taut string of length l fastened at its ends. Its motion is described by a function $u = u(x, t)$, which defines the vertical displacement of each point x of the string at time t . Our basic postulate is that the displacement u is small. Implicitly, we assume that the motion is in a plane and no element of the string moves horizontally—only vertically. At each instant of time we assume that the string has a density $\rho(x, t)$, with dimensions mass per unit length, and the tension in the string is given by a function $T(x, t)$, with force dimensions. By convention, $T(x, t)$ is the force on the segment to the left of x caused by the portion of the string to the right of x , and we assume that the tension always is directed along the tangent to the displacement profile at x .

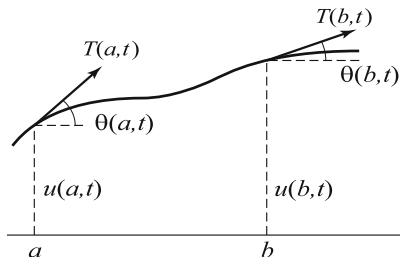

Figure 1.13 Displaced string with tension forces shown

This latter assumption implies that the string does not resist bending. A priori, we do not know ρ or T . Figure 1.13 shows an arbitrary segment of the string between $x = a$ and $x = b$. We denote the angle that the tangent makes with the horizontal by $\theta(x, t)$, and we observe that

$$\tan \theta(x, t) = u_x(x, t).$$

To obtain an equation of motion of the string, we appeal to mass balance and Newton's second law. First, mass balance implies that the mass of the segment at any time t must equal its mass in equilibrium position (which we take to be at $t = 0$). In symbols, this means

$$\int_a^b \rho(x, t) \sqrt{1 + u_x(x, t)^2} dx = \int_a^b \rho_0(x) dx,$$

where ρ_0 is the density of the string in equilibrium. (Note that

$$\sqrt{1 + u_x(x, t)^2} dx$$

is an element of arc length.) But this equation must hold for every segment $[a, b]$, and therefore we may equate the integrands to obtain

$$\rho(x, t) \sqrt{1 + u_x(x, t)^2} = \rho_0(x). \quad (1.36)$$

Next let us apply Newton's second law, which states that the time rate of change of the total momentum of the segment must equal the net external force. We shall assume that the only force acting on the segment is tension caused by the rest of the string; we ignore gravity and any damping forces—see Exercises 1 and 2. Because there is no horizontal motion of the segment, the horizontal forces must balance, or

$$T(b, t) \cos \theta(b, t) = T(a, t) \cos \theta(a, t).$$

Because this equation holds for all a and b , we have

$$T(x, t) \cos \theta(x, t) = \tau(t)$$

for some function τ . Now, the time rate of change of the total momentum of the segment must equal the net vertical force. That is,

$$\begin{aligned} \frac{d}{dt} \int_a^b \rho(x, t) u_t(x, t) \sqrt{1 + u_x(x, t)^2} dx \\ = T(b, t) \sin \theta(b, t) - T(a, t) \sin \theta(a, t). \end{aligned}$$

Using the result of equation (1.36) and bringing the derivative inside the integral sign gives

$$\int_a^b \rho_0(x) u_{tt}(x, t) dx = T(b, t) \sin \theta(b, t) - T(a, t) \sin \theta(a, t).$$

We observe that the right side of this equation can be written as

$$T(b, t) \cos \theta(b, t) [\tan \theta(b, t) - \tan \theta(a, t)],$$

or

$$\tau(t)(u_x(b, t) - u_x(a, t)).$$

Therefore,

$$\int_a^b \rho_0(x) u_{tt}(x, t) dx = \tau(t)(u_x(b, t) - u_x(a, t)).$$

By the fundamental theorem of calculus we can rewrite the right side as an integral, and we obtain

$$\int_a^b \rho_0(x) u_{tt}(x, t) dx = \tau(t) \int_a^b u_{xx}(x, t) dx.$$

Again using the arbitrariness of the interval of integration $[a, b]$, we deduce

$$\rho_0(x) u_{tt}(x, t) = \tau(t) u_{xx}(x, t), \quad 0 < x < l, \quad t > 0.$$

As an additional constitutive assumption, we assume that the tension $\tau(t) = \tau_0 = \text{constant}$, which is a good assumption for small displacements of the string. Thus, in the framework of the assumptions that we have made, we obtain a model equation for the transverse displacements, namely,

$$\rho_0(x) u_{tt} = \tau_0 u_{xx}. \tag{1.37}$$

If we introduce the function

$$c_0(x) = \sqrt{\tau_0 / \rho_0(x)},$$

then we can write (1.37) as

$$u_{tt} = c_0(x)^2 u_{xx}. \quad (1.38)$$

One should observe that c_0 has dimensions of speed. It is called the *wave speed*, and we shall observe that it measures the actual speed that waves travel along the string. In many applications the density of the string is a constant, and hence c_0 is constant; in that case equation (1.38) becomes

$$u_{tt} = c_0^2 u_{xx}, \quad (1.39)$$

which is called the **wave equation**; it is one of the fundamental equations in mathematics and applications.

If c_0 is constant, it is easy to check (Exercise 3) that $u = F(x - c_0 t)$ and $u = G(x + c_0 t)$ are solutions of the wave equation for any twice continuously differentiable functions F and G ; thus the wave equation admits both right- and left-traveling wave solutions. In fact, we shall show later that the general solution of the wave equation is the superposition (sum) of left- and right-traveling waves.

Our original assumption that the string is fastened at its ends $x = 0$ and $x = l$ translates into **boundary conditions**

$$u(0, t) = 0, \quad u(l, t) = 0, \quad t \geq 0. \quad (1.40)$$

To determine a unique displacement, we must impose **initial conditions** as well; that is, we prescribe both the position of the string and its velocity at time $t = 0$. Symbolically,

$$u(x, 0) = f(x), \quad u_t(x, 0) = g(x), \quad 0 \leq x \leq l. \quad (1.41)$$

In summary, to determine the displacement $u(x, t)$, we must solve the initial boundary value problem consisting of the PDE (1.39) subject to the boundary conditions (1.40) and initial conditions (1.41). We carry out this calculation in Chapter 2. We point out that this model is a small-displacement theory. A more complicated nonlinear model is required if we want to describe large displacements.

One-Dimensional Acoustics*

Acoustics is the science of sound and how signals are transmitted through a medium. We show that small disturbances, or sound signals, propagate as waves and are governed by the wave equation.

We restrict our attention to sound waves in a tube of cross-sectional area A , as in Figure 1.3, filled with a gas. In a fixed cross-section we assume no variation in any of the variables; the state variables will depend on x , the distance along

the tube, and time t . Thus our treatment is strictly one-dimensional. The state variables are mass density $\rho = \rho(x, t)$, velocity $v = v(x, t)$, and pressure $p = p(x, t)$. Here, the velocity is the actual velocity of the air particles as measured by a laboratory observer; the pressure is the force per unit area on the air to the right of the section at x , caused by the air to the left of the section at x .

The starting place for obtaining equations for acoustics is the basic balance law

$$u_t + \phi_x = f$$

introduced in Section 1.2. Here u is a density (quantity per unit volume), ϕ is the flux (quantity per unit area per unit time), and f is a source (quantity per unit volume per unit time). First, in gas flow we must balance mass. Therefore, take $u = \rho$, the mass density, and $\phi = \rho v$, which is the mass flux. There are no sources that create or destroy mass, so $f = 0$. Then **mass balance** is expressed by the equation

$$\rho_t + (\rho v)_x = 0. \quad (1.42)$$

Second, momentum must balance. Therefore, take $u = \rho v$, which is the momentum density (the same as the mass flux, in units of mass per area per time, or mass times velocity per unit volume), and take $\phi = (\rho v)v$, which is the momentum flux, or the rate at which momentum flows through a cross-section. But now there is a source term f because pressure gradients across the tube can create a net force that can change momentum (this is Newton's second law). So we take $f = -p_x$, and the **momentum balance law** becomes

$$(\rho v)_t + (\rho v^2)_x = -p_x.$$

The right side is a force per unit volume, which is the same as a momentum per unit volume per unit time; so it is like a momentum source term. The term is negative because a negative pressure gradient should cause motion to the right. We leave it as an exercise to show that the momentum balance equation can be written, using (1.42), as

$$\rho v_t + \rho v v_x + p_x = 0. \quad (1.43)$$

Equations (1.42) and (1.43) are the governing equations for gas flow in a tube. The equations are nonlinear and contain three unknowns, ρ, v , and p . For a third equation we assume a constitutive relation, or **equation of state**, of the form

$$p = F(\rho).$$

That is, the pressure is a function of density. We will assume that $F'(\rho) > 0$, or pressure increases with density. A typical assumption is $p = k\rho^\gamma$, where $k > 0, \gamma > 1$. (If the equation of state should also depend on temperature, as in an ideal gas, then we would require yet another equation: energy balance.)

Much of acoustical science deals with small disturbances in the gas. This leads to a simplified, linear approximation of equations (1.42)–(1.43). Let us assume that the gas in the tube is at rest, in a constant ambient state $\rho = \rho_0$, $v = 0$, $p_0 = F(\rho_0)$. Then we make a small disturbance, say at one end, and let $\rho = \rho_0 + \tilde{\rho}(x, t)$ and $v = \tilde{v}(x, t)$ be the resulting density and velocity, where $\tilde{\rho}$ and \tilde{v} are small deviations from the ambient state. For the pressure we have, by a Taylor expansion,

$$p = F(\rho_0 + \tilde{\rho}) = F(\rho_0) + F'(\rho_0)\tilde{\rho} + \cdots = p_0 + c^2\tilde{\rho} + \cdots,$$

where

$$c \equiv \sqrt{F'(\rho_0)}$$

is called the **sound speed**, and the three dots denote terms containing at least a $\tilde{\rho}^2$ factor. Note that c has velocity units because it is the square root of a derivative of pressure with respect to density. Substituting all these expressions into the mass and momentum balance laws (1.42)–(1.43) yields

$$\begin{aligned} (\rho_0 + \tilde{\rho})_t + ((\rho_0 + \tilde{\rho})\tilde{v})_x &= 0, \\ (\rho_0 + \tilde{\rho})\tilde{v}_t + (\rho_0 + \tilde{\rho})\tilde{v}\tilde{v}_x + (p_0 + c^2\tilde{\rho} + \cdots)_x &= 0. \end{aligned}$$

Now we *linearize* these two equations by discarding all products of small terms; the idea is that products of small terms are smaller than the small terms themselves. Therefore, we obtain the approximation

$$\tilde{\rho}_t + \rho_0\tilde{v}_x = 0, \quad \rho_0\tilde{v}_t + c^2\tilde{\rho}_x = 0. \quad (1.44)$$

These linearized equations are called the **acoustic approximation** equations. To repeat, $\tilde{\rho}$ and \tilde{v} are the small density and velocity deviations from an ambient state ρ_0 and $v = 0$.

Next take the t -derivative of the first equation in (1.44) and the x -derivative of the second equation and then subtract the results; we get

$$\tilde{\rho}_{tt} - c^2\tilde{\rho}_{xx} = 0.$$

This is the wave equation for the small density deviation $\tilde{\rho}$. Similarly,

$$\tilde{v}_{tt} - c^2\tilde{v}_{xx} = 0.$$

In other words, *small disturbances in the gas are propagated by the wave equation*. We recall that the wave equation admits solutions of the form $F(x - ct)$ and $G(x + ct)$, or right- and left-traveling waves moving at speed c . therefore, small density or velocity variations can move to the right, undistorted, at speed c . Large-amplitude disturbances, for example caused by an explosion, do not propagate in this way, and the full nonlinear theory embodied in (1.42)–(1.43)

must be applied. In this case waves can distort, and discontinuous solutions, called shock waves, can be produced. This is the same type of behavior we saw in Section 1.2 for nonlinear advection equations. See Logan (2008, 2013) for detailed discussions.

EXERCISES

1. In the derivation of the wave equation we assumed no gravitational force on the string. What is the model equation if gravity is included? If gravity acts at each point of the string, derive the equation

$$u_{tt} = c_0^2 u_{xx} - g,$$

where g is the constant acceleration due to gravity.

2. Repeat the derivation in this section when the vertical motion of the string is retarded by a damping force proportional to the velocity of the string. Obtain the **damped wave equation**

$$u_{tt} = c_0(x)^2 u_{xx} - k u_t,$$

where k is the constant damping coefficient.

3. Let c_0 be constant. Verify that $u = F(x - c_0 t)$ and $u = G(x + c_0 t)$ are solutions of (1.39) for any twice-differentiable functions F and G . If $F(x) = 1/(1 + x^2)$, sketch time profiles of the wave

$$u(x, t) = \frac{1}{2}(F(x - t) + F(x + t))$$

at $t = 0, 1, 3, 5$.

4. Consider the displacements of a string governed by the wave equation

$$u_{tt} = c^2 u_{xx}, \quad 0 \leq x \leq l,$$

where c is constant, and subject to the boundary conditions

$$u(0, t) = 0, \quad u(l, t) = 0, \quad t \geq 0.$$

Show that for any positive integer n there is a solution of the form

$$u_n(x, t) = \cos \frac{n\pi ct}{l} \sin \frac{n\pi x}{l}.$$

What are the initial conditions? Describe the motion of the string in the cases $n = 1$ and $n = 2$ (sketch several fixed time snapshots of the string

profile). In general, for any n , what is the temporal frequency of the oscillations represented by these solutions? These frequencies are called the **fundamental frequencies**, and the corresponding displacements are called the **fundamental modes**. How do the frequencies change as the length l of the string is changed? How do the frequencies depend on the tension? Discuss your answers in the context of a vibrating guitar string. These special solutions $u_n(x, t)$ are called **standing waves**.

5. The total energy of the string governed by equation (1.37) with boundary conditions (1.40) is defined by

$$E(t) = \int_0^l \left(\frac{1}{2} \rho_0 u_t^2 + \frac{1}{2} \tau_0 u_x^2 \right) dx.$$

Show that the total energy is constant for all $t \geq 0$. Hint: Multiply (1.37) by u_t and note that $(u_t^2)_t = 2u_t u_{tt}$ and $(u_t u_x)_x = u_t u_{xx} + u_{tx} u_x$. Then show

$$\frac{d}{dt} \int_0^l \rho_0 u_t^2 dx = \tau_0 u_t u_x \Big|_0^l - \frac{d}{dt} \int_0^l \tau_0 u_x^2 dx.$$

6. If the equation of state has the form $p = F(\rho) = k\rho^\gamma$, find an expression for the sound speed c . Using this equation of state with $\gamma = 1.4$, compute the speed that sound waves travel in air. Take the density of air to be 0.0013 gm per cubic cm.
7. Using the mass balance equation (1.42), show that the momentum balance equation $(\rho v)_t + (\rho v^2)_x = -p_x$ can be written in the form (1.43).
8. At the end ($x = 0$) of a long tube ($x \geq 0$) the density of air changes according to the formula $\tilde{\rho}(0, t) = 1 - \cos 2t$ for $t \geq 0$, and $\tilde{\rho}(0, t) = 0$ for $t < 0$. Find a solution to the wave equation in the domain $x > 0$, $-\infty < t < \infty$, in the form of a right-traveling wave that satisfies the given boundary condition. Take $c = 1$ and plot the solution surface.
9. (Transmission line) In a long transmission line the voltage $V = V(x, t)$ and current $I = I(x, t)$ (per unit length) satisfy the transmission line equations

$$I_x + CV_t + GV = 0, \quad V_x + LI_t + RI = 0,$$

where C is the capacitance, G is the leakage, R is the resistance, and L is the inductance (all per unit length) of the line. Show that both V and I satisfy the telegraph equation

$$LCu_{tt} + (RC + LG)u_t + RGu = u_{xx}.$$

Note that if $R = G = 0$, then I and V both satisfy the wave equation. What is the speed of waves?

1.6 Quantum Mechanics*

One of the fundamental equations of mathematical physics is the Schrödinger equation, which is the basic equation of quantum mechanics. In the next few paragraphs we give a brief description of Schrödinger's equation in one dimension.

Consider a particle of mass m moving on the x -axis under the influence of a continuous, conservative force $F(x)$, which depends only on the position x . According to the canon of classical particle physics, the motion $x = x(t)$ of the particle is governed by the dynamical equation

$$m \frac{d^2 x}{dt^2} = F(x), \quad (1.45)$$

which is Newton's second law of motion (mass times acceleration equals force). If the initial position $x(0)$ and initial velocity dx/dt at $t = 0$ are prescribed, then one can in theory solve the ODE model (1.45) subject to the initial conditions and actually determine the state of the particle, that is, its position and velocity, for all times $t > 0$. In this sense, classical mechanics is a *deterministic model*—knowledge of the initial state determines the future history of the particle.

In the early 1900s it was found that this classical, deterministic model of motion fails on the atomic scale. Quantum mechanics, a probabilistic model, grew out of the atomic physics revolution. Quantum theory dictates that the particle has no definite position or velocity; rather, one postulates a statistical, or probabilistic, interpretation of the state of the particle in terms of a **wave function** $\Psi(x, t)$. The square of the wave function, $|\Psi|^2$, is a probability density for the random position of the particle; that is,

$$\int_a^b |\Psi(x, t)|^2 dx$$

is interpreted as the probability of the particle being in the interval $a \leq x \leq b$ at time t . Thus $\int_{-\infty}^{\infty} |\Psi(x, t)|^2 dx = 1$, since the particle is located somewhere on the x -axis. From elementary probability theory it is known that the probability density $|\Psi(x, t)|^2$ contains all of the statistical information for a given problem (for example, the mean and variance of the position). Note that Ψ may be complex-valued, and thus $|\Psi|^2 = \Psi \overline{\Psi}$, where the overbar denotes complex conjugation.

So the question to finding the wave function. The equation that governs the evolution of a quantum-mechanical system (the analogue of (1.45) for a classical system) is the Schrödinger equation, a second-order partial differential equation having the form

$$i\hbar \Psi_t = -\frac{\hbar^2}{2m} \Psi_{xx} + V(x)\Psi, \quad x \in \mathbb{R}, \quad t > 0, \quad (1.46)$$

where $V = V(x)$ is the potential energy, m is the mass, and $\hbar = h/(2\pi)$, where $h = 6.625 \cdot 10^{-34}$ kg m²/s is Planck's constant. (Recall that associated with the force $F(x)$ is a potential function $V(x)$ defined by the equation $F(x) = -V'(x)$; that is, the force is the negative gradient of the potential.) One can motivate the Schrödinger equation from momentum and energy considerations, but here our goal is only to note the form of the equation. The reader is referred to one of the many excellent texts on quantum mechanics for a complete discussion (e.g., Griffiths (2005)). A popular equation studied in detail in the mathematical literature is the **free** Schrödinger equation

$$\Psi_t = i\Psi_{xx}, \quad (1.47)$$

where the potential V is taken to be zero (a free particle with no forces acting); the constants are taken to be unity. Note that this equation resembles the diffusion equation, but it has a complex coefficient; this simple alteration makes solutions of the two equations quite different.

One method to find solutions of (1.46) (we shall observe later that this method is basic in PDEs) is to assume that the variables separate, i.e., the solution has the form of a product $\Psi(x, t) = y(x)\phi(t)$. Substituting this into (1.46) gives, after rearrangement,

$$\frac{i\hbar\phi'(t)}{\phi(t)} = \frac{-\frac{\hbar^2}{2m}y''(x) + V(x)y(x)}{y(x)}.$$

Here, prime denotes the derivative. The left side of this equation depends only on t , and the right side depends only on x . The only way equality can occur for all t and all x is if both sides are equal to the same constant, which we call E (for *energy*). Therefore, we obtain two equations, one for ϕ ,

$$\frac{d\phi}{dt} = (-iE/\hbar)\phi, \quad (1.48)$$

and one for y , namely,

$$-\frac{\hbar^2}{2m}y'' + (V(x) - E)y = 0. \quad (1.49)$$

The solution of (1.48) is easily found to be

$$\phi = C \exp(-iEt/\hbar) = C(\cos(-Et/\hbar) - i \sin(Et/\hbar)),$$

where C is a constant. Thus, the temporal part is oscillatory (periodic). Equation (1.49), whose solution $y(x)$ gives the spatial part of the wave function, is called the **time-independent** Schrödinger equation, and it is one of the fundamental equations of mathematical physics. The values of E for which (1.49) has

a nontrivial solution $y(x)$ with $\int_{-\infty}^{\infty} y(x)^2 dx = 1$ are interpreted as the allowable energy levels. This is in contrast to the situation in classical mechanics, where any energy level is possible.

EXERCISES

1. Show that the ordinary differential equation $y'' + p(x)y' + q(x)y = 0$ can be transformed into the Schrödinger-like equation $u'' + r(x)u = 0$, $r = q - p'/2 - p^2/4$, without a first derivative, by the Liouville transformation

$$u = y \exp\left(\frac{1}{2} \int_a^x p(\xi) d\xi\right).$$

2. If the potential is $V(x) = \frac{k}{2}x^2$, then for a special value of E , equation (1.49) admits a solution of the form $y(x) = Ce^{-ax^2}$ for some $a > 0$ and any constant C . Determine a and E , and sketch a graph of the probability density function $|\Psi|^2$ in the case $k = m = \hbar$ (use a calculator to compute C). Numerically calculate the probability that the particle is in the interval $[0, 1]$.
3. Suppose $\Psi(x, t)$, $x \in \mathbb{R}$, $t > 0$, is a twice continuously differentiable function that satisfies (1.46), and both $|\Psi|$, $|\Psi_x| \rightarrow 0$ as $|x| \rightarrow \infty$. Show that

$$\int_{-\infty}^{\infty} |\Psi(x, t)|^2 dx = \text{constant}, \quad t > 0.$$

Hint: Take the time derivative of the left side, pulling it under the integral; use the Schrödinger equation and its complex conjugate, and finally integrate the terms like $\overline{\Psi}_{xx}\Psi$ by parts.

4. A free particle of mass m is confined to the interval $0 < x < \pi$, and $\Psi(0, t) = \Psi(\pi, t) = 0$ for all t . Show that the associated time-independent problem is

$$y'' + \frac{2mE}{\hbar^2}y = 0, \quad 0 < x < \pi; \quad y(0) = y(\pi) = 0.$$

Show that this problem has a nontrivial solution if, and only if, E is one of the values $n^2\hbar^2/(2m)$, $n = 1, 2, 3, \dots$. Sketch the probability density functions $y(x)^2$ corresponding to $n = 1$ and $n = 2$, and compute the probability that the particle is in the interval $[0, 0.25]$ in each case.

1.7 Heat Conduction in Higher Dimensions

Most physical problems occur in more than one spatial dimension. In this section we set up a PDE model for heat flow in three dimensions. The same ideas carry over to diffusion of chemicals or other biological quantities. This section may require some review of the concepts and definitions from multi-variable calculus. These notions include the gradient of a scalar function the divergence of a vector field, as well as key integral theorems.

The idea is exactly the same as in one dimension, namely to formulate an integral conservation law. Let Ω be a region in space where heat is flowing, and let $u = u(x, y, z, t)$ be the temperature at time t at the point (x, y, z) in Ω . We assume that the region is homogeneous and is characterized by a constant specific heat c and a constant density ρ . Now let B be an arbitrary sphere contained in Ω . See Figure 1.14.

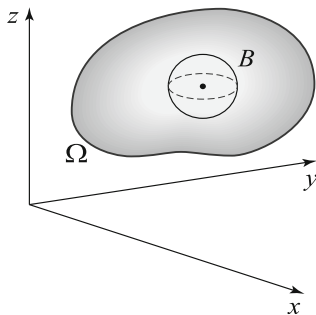

Figure 1.14 Arbitrary sphere B contained in a region Ω

We apply an energy balance principle to B , which states that the rate of change of the total heat energy in B must equal the rate at which heat flows into B across its boundary plus the rate at which heat energy is generated in B by sources. The total amount of heat in a small volume element $dV = dx dy dz$ is $c\rho u dV$, and thus the total amount of heat energy in B is given by the three-dimensional integral³

$$\text{Total amount of heat energy in } B = \int_B c\rho u dV.$$

³ For concise notation, double and triple integrals are often written as a single integral with the region of integration as a subscript. The context should indicate the type of integral, two- or three-dimensional.

We assume that the heat sources (or sinks) are given by a point function $f = f(x, y, z, t)$, where $f dV$ is the rate at which heat is generated in dV ; thus, the rate at which heat is generated in the whole of B is

$$\text{Rate that heat energy is produced in } B = \int_B f dV.$$

Note that f has dimensions of energy per unit volume, per unit time.

Next we introduce the heat flux vector $\phi = \phi(x, y, z, t)$; its direction corresponds to the direction of heat flow at position (x, y, z) at time t . The rate at which heat flows across an oblique surface element dA oriented by the outward unit normal vector \mathbf{n} is

$$\phi \cdot \mathbf{n} dA.$$

See Figure 1.15.

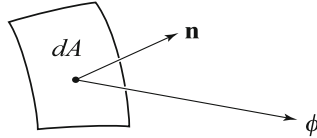

Figure 1.15 Heat flux through a surface element dA oriented by its outward unit normal vector \mathbf{n} is $\phi \cdot \mathbf{n} dA$

Consequently, the net rate that heat energy flows across the boundary⁴ of B , denoted by ∂B , is the surface integral

$$\int_{\partial B} \phi \cdot \mathbf{n} dA.$$

So, the conservation law, or energy balance law, is

$$\frac{d}{dt} \int_B c\rho u dV = - \int_{\partial B} \phi \cdot \mathbf{n} dA + \int_B f dV. \quad (1.50)$$

The minus sign appears on the flux integral because if the flow is outward, the integral is positive; the minus sign will cause the net energy on the left side of the equation to decrease, which is correct.

Next we apply one of the fundamental integral relations from multi-variable calculus—the *divergence theorem*. It permits us to rewrite the flux integral in (1.50) as a volume integral. The divergence theorem, a three-dimensional version of the fundamental theorem of calculus.

⁴ Two common notations for the boundary of a set B are ∂B and $\text{Bd } B$.

Theorem 1.22

(**Divergence theorem**) If the vector field ϕ is continuously differentiable on the region B and continuous on $B \cup \partial B$, where ∂B is the boundary, then

$$\int_B \operatorname{div} \phi \, dV = \int_{\partial B} \phi \cdot \mathbf{n} \, dA. \quad \square$$

Using the divergence theorem we can write energy balance equation (1.50) as

$$\frac{d}{dt} \int_B c\rho u \, dV = - \int_B \operatorname{div} \phi \, dV + \int_B f \, dV.$$

Now we can bring the time derivative under the integral on the left side and finally rearrange all the terms under one volume integral to obtain

$$\int_B (c\rho u_t + \operatorname{div} \phi - f) \, dV = 0.$$

This balance law must hold for every sphere B in Ω , and therefore the integrand must vanish, giving the partial differential equation

$$c\rho u_t + \operatorname{div} \phi = f \tag{1.51}$$

for all t and all $(x, y, z) \in \Omega$. Equation (1.51) is the local form of the heat energy **conservation law** in three dimensions.

The conservation law still contains two unknowns, the scalar temperature u and the vector heat flux ϕ . A constitutive relation can be postulated to connect the two. One such relation is the three-dimensional version of Fick's law, or **Fourier's heat conduction law**, which states, consistent with the laws of thermodynamics, that heat flows down the gradient. In symbols,

$$\phi = -K \operatorname{grad} u. \tag{1.52}$$

Recall from calculus that the negative gradient of a function points in the direction of maximum decrease. The proportionality constant K is the thermal conductivity. Substituting (1.52) into (1.51) and using the identity

$$\operatorname{div}(\operatorname{grad}) u = u_{xx} + u_{yy} + u_{zz},$$

we obtain the heat equation for the temperature $u = u(x, y, x, t)$ in three dimensions:

$$c\rho u_t - K(u_{xx} + u_{yy} + u_{zz}) = f. \tag{1.53}$$

The expression $u_{xx} + u_{yy} + u_{zz}$ is called the **Laplacian** of u , and it is denoted in this text by Δu . That is⁵,

$$\Delta u = u_{xx} + u_{yy} + u_{zz}.$$

⁵ In science and engineering texts, the Laplacian is often denoted by $\nabla^2 u$.

Finally, in summary, we can write the heat conduction equation as

$$u_t - k\Delta u = \frac{1}{c\rho}f, \quad (1.54)$$

where the constant $k = K/(c\rho)$ is called the **diffusivity**. Equation (1.54) is one of the fundamental equations of mathematical physics.

Remark. The heat conduction equation in two dimensions is exactly the same as (1.54) where the Laplacian is two dimensional:

$$\Delta u = u_{xx} + u_{yy}. \quad (1.55)$$

In two dimensions the region Ω is a planar region and $\partial\Omega$ is the region's boundary, a curve taken counterclockwise. \square

Generally, we expect that the three-dimensional heat equation (1.54), and similarly for the two-dimensional version, will come with auxiliary conditions in the form of an initial temperature condition

$$u(x, y, z, 0) = u_0(x, y, z) \quad \text{in } \Omega,$$

as well as conditions on the boundary $\partial\Omega$.

If the source term f and the boundary conditions on $\partial\Omega$ are independent of time, then we expect that the body Ω would eventually come to an equilibrium temperature $u = u(x, y, z)$ that is independent of time. This would occur long after the transients, or effects of the initial condition, decay away. From (1.54), because $u_t = 0$, we infer that this equilibrium temperature will satisfy the PDE

$$-k\Delta u = \frac{1}{c\rho}f,$$

which is **Poisson's equation**. If there are no sources, $f(x, y, z) \equiv 0$, then $u = u(x, y, z)$ satisfies **Laplace's equation**

$$\Delta u = 0 \quad \text{in } \Omega. \quad (1.56)$$

Laplace's equation, which is discussed in the next section and in Chapter 4, is one of the most famous models in the mathematical sciences, and it governs many phenomena besides equilibrium temperatures.

Because Laplace's equation (1.56) does not contain time, we expect that only boundary conditions should be appended in order to have a physically well-posed problem. We can prescribe the temperature on the boundary of Ω , that is,

$$u(x, y, z) = g(x, y, z), \quad (x, y, z) \in \partial\Omega,$$

which is a **Dirichlet condition**; or we can prescribe the heat flux on the boundary, that is,

$$-K \operatorname{grad} u \cdot \mathbf{n} = h(x, y, z), \quad (x, y, z) \in \partial\Omega,$$

which is a **Neumann condition**. If no heat flows across the boundary, then $h = 0$, and we say that the **boundary is insulated**. As in one dimension, we may also have a **radiation condition** of the form

$$-K \operatorname{grad} u \cdot \mathbf{n} = -h(u - g), \quad \text{on } \partial\Omega.$$

where $h > 0$ is the heat loss coefficient and $g = g(x, y, z)$ is the given environmental temperature. An alternate notation for the derivative on the left side is $\operatorname{grad} u \cdot \mathbf{n} = \frac{du}{dn}$, which is called the **normal derivative** of u in the direction of the outward unit normal. Thus the radiation condition is often written

$$-K \frac{du}{dn} = -h(u - g), \quad \text{on } \partial\Omega.$$

For beginning students, learning the notation associated with partial differential equations, especially in higher dimensions, may be a difficult task. As you use the notation and become comfortable with it, it should become evident that it is *only* notation and not as difficult as it appears.

EXERCISES

1. Let $u = u(x, y, z)$ be a scalar field. Verify that

$$\operatorname{div}(\operatorname{grad} u) = u_{xx} + u_{yy} + u_{zz}.$$

2. What is the form of the conservation law (1.51) if the thermal conductivity K in Fourier's law (1.52) depends on position, i.e., $K = K(x, y, z)$? (In this case we say that the medium is heterogeneous.)
3. Suppose $u = u(x, y, z)$ is a solution of the Neumann problem

$$\begin{aligned} -K\Delta u &= f, \quad (x, y, z) \in \Omega, \\ -K \operatorname{grad} u \cdot \mathbf{n} &= g(x, y, z), \quad (x, y, z) \in \partial\Omega, \end{aligned}$$

where f and g are functions of x, y, z . Show that f and g must satisfy the relation

$$\int_{\Omega} f \, dV = \int_{\partial\Omega} g \, dA.$$

In terms of steady heat flow, what is the physical meaning of this relation? Hint: Integrate the PDE.

4. Let w be a scalar field and ϕ a vector field. Verify the vector identity

$$\operatorname{div}(w\phi) = \phi \cdot \operatorname{grad} w + w \operatorname{div} \phi.$$

Integrate this equation over Ω and take $\phi = \operatorname{grad} u$, where u is a scalar field, to prove **Green's identity**

$$\int_{\Omega} w \Delta u \, dV = - \int_{\Omega} \operatorname{grad} u \cdot \operatorname{grad} w \, dV + \int_{\partial\Omega} w \operatorname{grad} u \cdot \mathbf{n} \, dA.$$

5. Show that if the Dirichlet problem

$$\begin{aligned} \Delta u &= \lambda u, & (x, y, z) \in \Omega, \\ u &= 0, & (x, y, z) \in \partial\Omega, \end{aligned}$$

has a nontrivial solution $u = u(x, y, z)$, then λ must be negative. Hint: Multiply the equation by u and integrate over Ω ; use Green's identity in Exercise 4.

6. (**Dirichlet's principle**) Suppose that u satisfies the Dirichlet problem

$$\begin{aligned} \Delta u &= 0, & (x, y, z) \in \Omega, \\ u &= f, & (x, y, z) \in \partial\Omega. \end{aligned}$$

Show that

$$\int_{\Omega} |\operatorname{grad} u|^2 \, dV \leq \int_{\Omega} |\operatorname{grad} w|^2 \, dV$$

for any other function w that satisfies $w = f$ on $\partial\Omega$. Thus, the solution to the Dirichlet problem *minimizes the energy*

$$\int_{\Omega} |\operatorname{grad} w|^2 \, dV.$$

Hint: Let $w = u + v$, where $v = 0$ on $\partial\Omega$, and expand $\int_{\Omega} |\operatorname{grad} w|^2 \, dV$ using Green's identity.

7. If heat is both diffusing and advecting in a spatial domain with flux given by

$$\phi = -K \operatorname{grad} u + u \mathbf{v},$$

where \mathbf{v} is nonconstant vector advection velocity, show that the governing advection–diffusion equation is given by

$$c\rho u_t = K \Delta u - (\operatorname{div} \mathbf{v})u - \mathbf{v} \cdot \operatorname{grad} u.$$

1.8 Laplace's Equation

In the last section we derived Laplace's equation:

$$\begin{aligned}\Delta u &= u_{xx} + u_{yy} = 0 && \text{(two dimensions)} \\ \Delta u &= u_{xx} + u_{yy} + u_{zz} = 0 && \text{(three dimensions)}\end{aligned}$$

We observed that Laplace's equation models steady heat flow in a region where the temperature is fixed on the boundary. Working in two dimensions, we show what Laplace's equation tells us physically. Let (x, y) be some point in the region where heat is flowing and let h be a small increment. By Taylor's theorem we have

$$u(x - h, y) = u(x, y) - hu_x(x, y) + \frac{1}{2}h^2u_{xx}(x, y) - \frac{1}{6}h^3u_{xxx}(x, y) + O(h^4),$$

where $O(h^4)$ denotes the remaining terms (the error). Moreover,

$$u(x + h, y) = u(x, y) + hu_x(x, y) + \frac{1}{2}h^2u_{xx}(x, y) + \frac{1}{6}h^3u_{xxx}(x, y) + O(h^4).$$

Adding these two expressions and solving for u_{xx} gives

$$u_{xx}(x, y) = \frac{u(x - h, y) - 2u(x, y) + u(x + h, y)}{h^2} + O(h^2),$$

where $O(h^2)$ denotes terms that are quadratic in h . This expression on the right side is a difference-quotient approximation to the second partial derivative u_{xx} at (x, y) , and the error is proportional to h^2 . Performing the same calculation, but now incrementing y instead of x , we obtain the approximation

$$u_{yy}(x, y) = \frac{u(x, y - h) - 2u(x, y) + u(x, y + h)}{h^2} + O(h^2).$$

Therefore, Laplace's equation at (x, y) can be approximated by the equation

$$\begin{aligned}\Delta u(x, y) &= \frac{u(x - h, y) - 2u(x, y) + u(x + h, y)}{h^2} \\ &\quad + \frac{u(x, y - h) - 2u(x, y) + u(x, y + h)}{h^2} + O(h^2) \\ &= 0.\end{aligned}$$

Solving for $u(x, y)$ gives, approximately, upon neglecting the small-order terms,

$$u(x, y) = \frac{1}{4}(u(x - h, y) + u(x + h, y) + u(x, y - h) + u(x, y + h)). \quad (1.57)$$

Equation (1.57) states, physically, that the temperature at a point (x, y) is approximately the average of the temperatures at the four nearby points

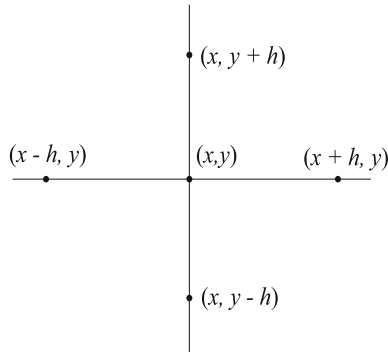

Figure 1.16 If u satisfies Laplace's equation, then the temperature at (x, y) is approximately the average of the temperatures at the four nearby points

$(x-h, y)$, $(x+h, y)$, $(x, y-h)$, $(x, y+h)$. See Figure 1.16. Therefore, the temperature at (x, y) cannot exceed the temperatures at the neighboring points; so a maximum could not occur at (x, y) . Similarly, a minimum could not occur at (x, y) .

This important physical interpretation can be extended to a circle. If $u = u(x, y)$ satisfies Laplace's equation at a point $P : (x_0, y_0)$ in a region, then the temperature at P is the average value of the temperature on any circle $C_R(P)$ of radius R centered at P lying in the region; in symbols,

$$u(x_0, y_0) = \frac{1}{2\pi R} \int_{C_R(P)} u(x, y) ds.$$

The integral here is a line integral along the curve $C_R(P)$, taken counterclockwise. Of course, this result generalizes to three dimensions: The steady-state temperature at a point is the average of the temperatures over the surface of any sphere centered at that point.

If the value of u at a point is the average of the values on any circle about that point, then the value of u at that point cannot exceed every value of u on any given circle (assuming u is not a constant function). This implies that a function u satisfying Laplace's equation in a given circle cannot have a local maximum or local minimum at a point inside that circle; the maximum, or minimum, must therefore occur on the boundary. Indeed, this even true for much general regions, and the result is called the maximum principle. We state the result precisely.

Theorem 1.23

(The maximum principle) Let $u(x, y)$ satisfy Laplace's equation in Ω , an open, bounded, connected region in the plane; and let u be continuous on the closed domain $\Omega \cup \partial\Omega$ consisting of Ω and its boundary. If u is not a constant function, then the maximum and minimum values of u are attained on the boundary of Ω and nowhere inside Ω . \square

This result is also true in three dimensions. This is one of the fundamental properties of solutions to Laplace's equation.

The proof of the maximum principle is not difficult and requires only a couple of concepts from multivariable calculus. We show that the maximum must occur on the boundary; the argument for the minimum is similar. Let $w(x, y) = u(x, y) + \varepsilon(x^2 + y^2)$, where $\varepsilon > 0$. Then

$$\Delta w = \Delta u + 4\varepsilon = 4\varepsilon > 0.$$

Therefore $\Delta w > 0$ in Ω . From calculus, if w has a maximum at a point $P = (x, y)$ in Ω , then at P we know $w_{xx}, w_{yy} \leq 0$. But this contradicts $\Delta w > 0$. Thus the maximum must occur at some point $P_M = (x_M, y_M)$ on $\partial\Omega$. Then,

$$\begin{aligned} u(x, y) &= w(x, y) - \varepsilon(x^2 + y^2) < w(x, y) \\ &\leq w(P_M) = u(P_M) + \varepsilon\|P_M\|^2 < u(P_M) + \varepsilon L^2, \end{aligned}$$

where L is the maximum distance from the origin to the boundary of Ω . Therefore, because ε is arbitrary,

$$u(x, y) \leq u(P_M)$$

for all (x, y) in Ω . \square

Polar and Spherical Coordinates

Many two-dimensional problems involving Laplace's equation are in regions (circles, wedges, annuli) that lend themselves to a polar description in terms of r and θ , rather than rectangular coordinates x and y . This means that we need an expression for the Laplacian in terms of polar coordinates; the connection between polar and rectangular coordinates is given by the familiar formulae

$$x = r \cos \theta, \quad y = r \sin \theta,$$

or, inversely,

$$r = \sqrt{x^2 + y^2}, \quad \theta = \arctan \frac{y}{x}.$$

The chain rule allows us to calculate the partial derivatives u_{xx} and u_{yy} in terms of derivatives with respect to r and θ . First, we calculate $\partial u/\partial x$; we have

$$\frac{\partial u}{\partial x} = u_r r_x + u_\theta \theta_x = (\cos \theta) u_r - \frac{\sin \theta}{r} u_\theta.$$

So, an x partial derivative produces the operation

$$\frac{\partial}{\partial x} = \cos \theta \frac{\partial}{\partial r} - \frac{\sin \theta}{r} \frac{\partial}{\partial \theta}$$

in polar coordinates. Therefore, the second partial is

$$\begin{aligned} \left(\frac{\partial}{\partial x} \right)^2 &= \left(\cos \theta \frac{\partial}{\partial r} - \frac{\sin \theta}{r} \frac{\partial}{\partial \theta} \right)^2 \\ &= \cos^2 \theta \frac{\partial^2}{\partial r^2} - \frac{2 \sin \theta \cos \theta}{r} \frac{\partial^2}{\partial r \partial \theta} \\ &\quad + \frac{\sin^2 \theta}{r^2} \frac{\partial^2}{\partial \theta^2} + \frac{2 \cos \theta \sin \theta}{r^2} \frac{\partial}{\partial \theta} + \frac{\sin^2 \theta}{r} \frac{\partial}{\partial r}. \end{aligned}$$

The reader should verify these calculations. Similarly, one finds that

$$\begin{aligned} \left(\frac{\partial}{\partial y} \right)^2 &= \left(\sin \theta \frac{\partial}{\partial r} + \frac{\cos \theta}{r} \frac{\partial}{\partial \theta} \right)^2 \\ &= \sin^2 \theta \frac{\partial^2}{\partial r^2} + \frac{2 \sin \theta \cos \theta}{r} \frac{\partial^2}{\partial r \partial \theta} \\ &\quad + \frac{\cos^2 \theta}{r^2} \frac{\partial^2}{\partial \theta^2} - \frac{2 \cos \theta \sin \theta}{r^2} \frac{\partial}{\partial \theta} + \frac{\cos^2 \theta}{r} \frac{\partial}{\partial r}. \end{aligned}$$

Upon adding these two equations there is a lot of cancelation, and we obtain

$$\Delta u = u_{rr} + \frac{1}{r} u_r + \frac{1}{r^2} u_{\theta\theta} = 0,$$

which is **Laplace's equation in polar coordinates**.

In three dimensions, problems often occur on regions that have cylindrical symmetry (e.g., portions of cylinders) or spherical symmetry (e.g., portions of spheres). Therefore, it is useful to have expressions for the Laplacian in cylindrical coordinates r, θ, z and spherical coordinates ρ, θ, ϕ . Cylindrical coordinates in space are defined by the equations

$$x = r \cos \theta, \quad y = r \sin \theta, \quad z = z,$$

which are just polar coordinates in the plane appended by z . The **Laplace's equation in cylindrical coordinates** is

$$\Delta u = u_{rr} + \frac{1}{r} u_r + \frac{1}{r^2} u_{\theta\theta} + u_{zz} = 0.$$

Spherical coordinates (see Figure 1.17) are related to rectangular coordinates by the transformation formulae

$$x = \rho \sin \phi \cos \theta, \quad y = \rho \sin \phi \sin \theta, \quad z = \rho \cos \phi.$$

Laplace's equation in spherical coordinates is

$$\Delta u = u_{\rho\rho} + \frac{2}{\rho}u_{\rho} + \frac{1}{\rho^2 \sin \phi}(\sin \phi u_{\phi})_{\phi} + \frac{1}{\rho^2 \sin^2 \phi}u_{\theta\theta} = 0.$$

Clearly, it is a tedious calculation using the chain rule to derive this formula, and we leave its verification as an exercise.

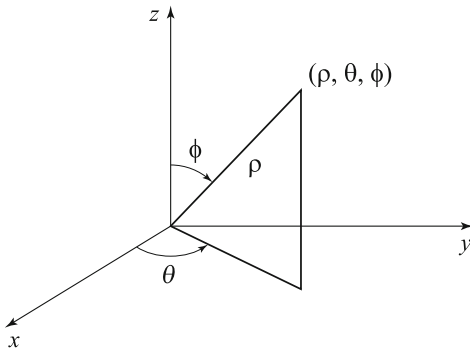

Figure 1.17 Spherical coordinates ρ , θ , and ϕ

When symmetries are involved, these expressions for the Laplacian can simplify significantly.

Example 1.24

Find the steady temperatures in the region between two concentric spheres of radii $\rho = 1$ and $\rho = 2$ if the inner sphere is held at zero degrees and the outer sphere is held at 10 degrees. Because there is no variation of the temperature on the boundaries in the longitudinal (θ) direction or in the azimuthal (ϕ) direction, it is clear that the steady temperature depends only on the distance ρ from the center of the coordinate system. That is, $u = u(\rho)$. Then, in spherical coordinates, Laplace's equation simplifies to

$$u''(\rho) + \frac{2}{\rho}u'(\rho) = 0.$$

This is the same as

$$\frac{d}{d\rho}(\rho^2 u') = 0.$$

Integrating twice with respect to ρ gives

$$u(\rho) = \frac{a}{\rho} + b,$$

where a and b are constants of integration. Now, $u(1) = 0$ forces $b = -a$, and then $u(2) = 10$ forces $a = -20$. Therefore, the steady temperatures vary radially according to

$$u(\rho) = 20 \left(1 - \frac{1}{\rho} \right). \quad \square$$

EXERCISES

1. In two dimensions suppose $u = u(r, \theta)$ satisfies Laplace's equation $\Delta u = 0$ in the disk $0 \leq r < 2$, and on the boundary it satisfies $u(2, \theta) = 3 \sin 2\theta + 1$, $0 \leq \theta < 2\pi$. What is the value of u at the origin? Where do the maximum and minimum of u occur in the closed domain $0 \leq r \leq 2$?

2. Solve Laplace's equation

$$u_{xx} + u_{yy} = 1$$

in the circle $r < a$ with $u = 0$ on $r = a$.

3. Laplace's equation in one dimension is $u''(x) = 0$, which has general solution $u(x) = ax + b$, where a and b are constants. Find the steady-state temperature distribution in a metal bar of length l whose ends at $x = 0$ and $x = l$ are held at temperatures T_0 and T_1 , respectively. Sketch a graph showing this distribution. Suppose the right end at $x = l$ is insulated; now what is the steady-state temperature distribution if the left end is held at T_0 degrees?
4. Solve $\Delta u = 1$ in the spherical shell $a < \rho < b$ with $u = 0$ on $\rho = a$ and $u_\rho = 0$ on $\rho = b$.
5. Suppose a metal bar of unit length has a variable conductivity $K(x)$ given by $K(x) = 1 + x^2$, $0 \leq x \leq 1$. What is the steady-state temperature distribution $u(x)$ if $u(0) = 1$ and $u(1) = 4$? (Recall that steady temperatures are modeled by the equation $-(K(x)u)' = 0$.)
6. Find all radial solutions to the two-dimensional Laplace's equation. That is, find all solutions of the form $u = u(r)$, where $r = \sqrt{x^2 + y^2}$. Find the steady-state temperature distribution in the annular domain $1 \leq r \leq 2$ if the inner circle $r = 1$ is held at 0 degrees and the outer circle $r = 2$ is held at 10 degrees.

7. A spherical shell with inner radius 1 and outer radius 2 has a steady-state temperature distribution. Its inner boundary is held at 100 degrees and at its outer boundary $u_\rho = -b < 0$. (a) Find the temperature distribution. (b) Can you find a value of b so that the temperature on the outer boundary is 20 degrees?
8. Show that Laplace's equation $u_{xx} + u_{yy} = 0$ in two dimensions is invariant under a translation of coordinates $\xi = x + a$, $\eta = y + b$; that is, show

$$u_{\xi\xi} + u_{\eta\eta} = 0.$$

Show that it is invariant under rotations

$$\xi = x \cos \alpha + y \sin \alpha, \quad \eta = -x \sin \alpha + y \cos \alpha.$$

9. In a three-dimensional spherical region D free of charges, the static electric-field vector \mathbf{E} satisfies the two Maxwell equations

$$\operatorname{div} \mathbf{E} = 0, \quad \operatorname{curl} \mathbf{E} = 0.$$

Let $V = V(x, y, z)$ be the electrical potential defined by $\operatorname{grad} V = \mathbf{E}$. (Review multi-variable calculus to see why such a potential exists.) Show that $\Delta V = 0$. That is, the static electric field potential satisfies Laplace's equation.

10. This exercise illustrates an important numerical procedure for solving Laplace's equation on a rectangle. Consider Laplace's equation on the rectangle $D : 0 < x < 4$, $0 < y < 3$ with boundary conditions given on the bottom and top by $u(x, 0) = 0$, $u(x, 3) = 0$ for $0 \leq x \leq 4$ and boundary conditions given on the sides by $u(0, y) = 2y(3 - y)$, $u(4, y) = 0$ for $0 \leq y \leq 4$. Apply the average value property (1.45) with $h = 1$ at each of the six lattice points $(1, 1)$, $(1, 2)$, $(2, 1)$, $(2, 2)$, $(3, 1)$, $(3, 2)$ inside D to obtain a system of six equations for the six unknown temperatures $u(i, j)$, $i = 1, 2, 3$; $j = 1, 2$. Solve the system to approximate the steady temperature distribution and plot the resulting approximate surface using a software package.

1.9 Classification of PDEs

An ordinary differential equation is classified according to its order (the highest derivative that appears) and whether it is linear or nonlinear. PDE models are more difficult to classify. Not only are order and linearity important issues, but the PDE structure is equally important. In fact, the structure of a PDE

dictates what types of boundary and initial conditions can be imposed to yield a well-posed problem, and ultimately what types of physical processes the PDE covers.

To fix the notion, we consider second-order equations. We have already obtained three model equations:

$$\begin{aligned}u_t - ku_{xx} &= 0 && \text{(diffusion equation),} \\u_{tt} - c^2u_{xx} &= 0 && \text{(wave equation),} \\u_{xx} + u_{yy} &= 0 && \text{(Laplace's equation).}\end{aligned}$$

The first two are *evolution equations*, which describe how a process evolves in time; we expect that each would require initial data that give the state of the system at time $t = 0$. The third is an equilibrium equation where time is not an issue—we expect that only boundary conditions are appropriate. Moreover, we infer that solutions of these three equations behave differently. Diffusion tends to smear out signals, whereas waves tend to propagate signals with some coherence (e.g., a traveling wave); solutions to Laplace's equation are steady-state and do not vary in time at all. Therefore, if we were to classify these three equations physically, we would call them **diffusive**, **wave-like**, and **static**, respectively. But there is a consistent characterization based on the form of the equation alone.

In general, let us consider a second-order differential equation of the form

$$Au_{xx} + Bu_{xt} + Cu_{tt} + F(x, t, u, u_x, u_t) = 0, \quad (1.58)$$

where A , B , and C are constants. Notice that the second-order derivatives are assumed to appear linearly, or to the first degree; the expression

$$Lu \equiv Au_{xx} + Bu_{xt} + Cu_{tt}$$

is called the **principal part** of the equation, and it is on this part that we base the classification. Observe that we used independent variables x and t ; should the problem involve only spatial variables, we would replace t by y . The classification is based on the sign of the quantity

$$D \equiv B^2 - 4AC,$$

which is called the **discriminant**.

Definition. If $D > 0$, we say that (1.58) is **hyperbolic**; if $D < 0$, we say that (1.58) is **elliptic**; if $D = 0$, we say that (1.58) is **parabolic**. \square

Under this classification, it is easy to check that the *diffusion equation is parabolic*, the *wave equation is hyperbolic*, and *Laplace's equation is elliptic*. This terminology comes from the familiar classification of plane curves; for

example, $Ax^2 + Ct^2 = 1$, where $A, C > 0$, $B = 0$ (and so $D < 0$) plots as an ellipse in the xt -plane, and $Ax^2 - Ct^2 = 1$ plots as a hyperbola, and so forth. As it turns out, all parabolic equations are diffusion-like, all hyperbolic equations are wave-like, and all elliptic equations are static. Later we show why this is true.

If A , B , and C are not constants, but rather functions of the independent variables x and t , then the discriminant $D = D(x, t)$ depends on x and t . We make the same definitions in this case, but now the sign of D can change, depending upon the domain. Problems that change type from one region to another can be difficult, and we do not consider them in this text. Classification of systems of PDEs is also possible, as well as classification of PDEs with nonlinear principal parts where the coefficients A , B , and C depend on the solution u itself. The reader is referred to a more advanced treatment for a discussion.

Now we show that the principal part Lu in equation (1.58) can be simplified for each of the three types by introducing a new set of independent variables. This strategy of searching for a change of variables that simplifies a problem is common in differential equations. We examine the case where A , B , and C are constant, and we seek a linear transformation

$$\xi = ax + bt, \quad \tau = cx + dt$$

that simplifies the PDE. Here ξ and τ are new independent variables, and a , b , c , and d are to be determined. We assume that $ad - bc \neq 0$, so that the transformation is invertible, that is, we may solve for x and t in terms of ξ and τ . The dependent function u in the new variables will be denoted by $U = U(\xi, \tau)$; that is, $u(x, t) = U(ax + bt, cx + dt)$. Then, by the chain rule for derivatives,

$$\begin{aligned} u_x &= U_\xi \xi_x + U_\tau \tau_x = aU_\xi + cU_\tau, \\ u_t &= U_\xi \xi_t + U_\tau \tau_t = bU_\xi + dU_\tau. \end{aligned}$$

To get the second partial requires another application of the chain rule. We have

$$\begin{aligned} u_{xx} &= \frac{\partial}{\partial x}(aU_\xi + cU_\tau) \\ &= a(aU_{\xi\xi} + cU_{\xi\tau}) + c(aU_{\xi\tau} + cU_{\tau\tau}) \\ &= a^2U_{\xi\xi} + 2acU_{\xi\tau} + c^2U_{\tau\tau}. \end{aligned}$$

The other two second partial derivatives are computed similarly, and we get

$$\begin{aligned} u_{tt} &= b^2U_{\xi\xi} + 2bdU_{\xi\tau} + d^2U_{\tau\tau}, \\ u_{xt} &= abU_{\xi\xi} + (ad + cb)U_{\xi\tau} + cdU_{\tau\tau}. \end{aligned}$$

Substituting these quantities into the principal part and collecting terms, we get

$$Au_{xx} + Bu_{xt} + Cu_{tt} = (Aa^2 + Bab + Cb^2)U_{\xi\xi} \quad (1.59)$$

$$+ (2acA + B(ad + bc) + 2Cbd)U_{\xi\tau} \quad (1.60)$$

$$+ (Ac^2 + Bcd + Cd^2)U_{\tau\tau}. \quad (1.61)$$

Now we can select a, b, c, d so that some of the second partial derivatives in the new variables disappear. This process must be handled differently depending on the sign of the discriminant D .

Hyperbolic case, $D > 0$. We have some flexibility, so let us choose $a = c = 1$. Then the coefficients of $U_{\xi\xi}$ and $U_{\tau\tau}$, which have the same form, become quadratic expressions in b and d , respectively, and we can force those coefficients to vanish by choosing

$$b = \frac{-B + \sqrt{D}}{2C}, \quad d = \frac{-B - \sqrt{D}}{2C}. \quad (1.62)$$

Here we have just used the quadratic formula. The remaining coefficient, that of $U_{\xi\tau}$, is nonzero (we leave this as an exercise). In summary, the transformation

$$\xi = x + \left(\frac{-B + \sqrt{D}}{2C} \right) t, \quad \tau = x + \left(\frac{-B - \sqrt{D}}{2C} \right) t \quad (1.63)$$

transforms the PDE (1.58) into a simpler equation of the form

$$U_{\xi\tau} + G(\xi, \tau, U, U_\xi, U_\tau) = 0,$$

where only the mixed second partial derivative appears. Thus there is a significant simplification over (1.63), where all the second partial derivatives occur.

This latter equation is called the **canonical form** of a hyperbolic equation, and the coordinates ξ and τ defined by (1.63) are called the **characteristic coordinates**. Transformation to these coordinates is almost always a preferred strategy for hyperbolic PDEs.

Finally, if $C = 0$, then (1.62) is not valid; in this case select $b = d = 1$ and

$$a = \frac{-B + \sqrt{D}}{2A}, \quad c = \frac{-B - \sqrt{D}}{2A}.$$

Parabolic case, $D = 0$. Now equations (1.62) give $b = d$, and the resulting transformation $\xi = x + bt$, $\tau = x + bt$ is not invertible. So we must proceed differently. Observe that if we choose $a = c = 1$, $d = -B/(2C)$, and $b = 0$,

then the coefficients of $U_{\tau\tau}$ and $U_{\xi\tau}$ in (1.61) both vanish (another exercise!). Hence, the transformation

$$\xi = x, \quad \tau = x - \frac{B}{2C}t$$

transforms equation (1.58) into

$$U_{\xi\xi} + H(\xi, \tau, U, U_{\xi}, U_{\tau}) = 0,$$

where only a double partial appears, and this is the **canonical form** in the parabolic case. Observe its similarity to the heat equation, where there is only a single second derivative.

Elliptic case, $D < 0$. Now b and d in (1.62) are conjugate complex numbers, i.e., $d = \bar{b}$. Selecting $a = c = 1$, we obtain a complex transformation

$$\xi = x + bt, \quad \tau = x + \bar{b}t.$$

But then, a real transformation can be found by taking real variables

$$\alpha = \frac{1}{2}(\xi + \tau), \quad \beta = \frac{1}{2i}(\xi - \tau).$$

It is an exercise to show that this transforms (1.58) into the equation

$$U_{\alpha\alpha} + U_{\beta\beta} + K(\alpha, \beta, U, U_{\alpha}, U_{\beta}) = 0,$$

where both double partial derivatives are present and the mixed partial is absent; the last equation is the **canonical form** for elliptic equations. We recognize the combination of second partial derivatives as the Laplacian operator.

Generally, characteristic coordinates are useful only for hyperbolic equations, and they do not play a particularly important role in elliptic and parabolic equations. First order equations, like a reaction–advection equation, are classified as hyperbolic because they propagate signals like the wave equation.

EXERCISES

1. Classify the PDE

$$u_{xx} + 2ku_{xt} + k^2u_{tt} = 0, \quad k \neq 0.$$

Find a transformation $\xi = x + bt$, $\tau = x + dt$ of the independent variables that transforms the equation into a simpler equation of the form $U_{\xi\xi} = 0$. Find the solution to the given equation in terms of two arbitrary functions.

2. Find the solution of the PDE

$$2u_{xx} - 4u_{xt} + u_x = 0$$

in terms of two arbitrary functions.

3. Classify the PDE

$$xu_{xx} - 4u_{xt} = 0$$

in the region $x > 0$. Observe that the PDE has variable coefficients. Solve the equation by making the *nonlinear* change of variables $\xi = t$, $\tau = t + 4 \ln x$. The solution is

$$u = e^{-t/4} f(t + 4 \ln x) + g(t),$$

where f and g are arbitrary functions.

4. Show that the equation

$$u_{tt} - c^2 u_{xx} + au_t + bu_x + du = f(x, t)$$

can be transformed into an equation of the form

$$w_{\xi\tau} + kw = g(\xi, \tau), \quad w = w(\xi, \tau)$$

by first making the transformation $\xi = x - ct$, $\tau = x + ct$ and then letting $u = we^{\alpha\xi + \beta\tau}$ for some choice of α, β .

5. Classify the PDE

$$u_{xx} - 6u_{xy} + 12u_{yy} = 0.$$

Find a transformation of independent variables that changes it to Laplace's equation.

6. Classify the PDE

$$x^2 u_{xx} + 2xu_{xt} + u_{tt} = u_t$$

and find the general solution using the nonlinear transformation $\xi = xe^{-t}$, $\tau = t$.

7. Classify the following PDEs with variable coefficients and sketch regions where they are of different type.

a) $yu_{xx} - 2u_{xy} + xu_{yy} = 0.$

b) $(1+x)u_{xx} + 2xyu_{xy} - y^2u_{yy} = 0.$

8. Show that the diffusion equation is diffusive and the wave equation is neither diffusive or dispersive. (See Exercises 12, 13, Section 1.1).

2

Partial Differential Equations on Unbounded Domains

In our study of PDEs we noted the differences among the types of equations: parabolic, hyperbolic, and elliptic. Those classifications dictate the types of initial and boundary conditions that should be imposed to obtain a well-posed problem. There is yet another division that makes one *method* of solution preferable over another, namely, the nature and extent of the spatial domain. Spatial domains may be bounded, like a bounded interval, or unbounded, like the entire set of real numbers. It is a matter of preference which type of domain is studied first. It seems that boundaries in a problem, which require boundary conditions, make a problem more difficult. Therefore, we first investigate problems defined on unbounded domains.

2.1 Cauchy Problem for the Heat Equation

We begin with the heat, or diffusion, equation on the real line. That is, we consider the initial value problem

$$u_t = ku_{xx}, \quad x \in \mathbb{R}, \quad t > 0, \quad (2.1)$$

$$u(x, 0) = \phi(x), \quad x \in \mathbb{R}. \quad (2.2)$$

Physically, this problem is a model of heat flow in an infinitely long bar where the initial temperature $\phi(x)$ is prescribed. In a chemical or biological con-

text, the equation governs density variations under a diffusion process. Notice that there are no boundaries in the problem, so we do not prescribe boundary conditions explicitly. However, for problems on infinite domains, conditions at infinity are sometimes either stated explicitly or understood. Such a condition might require boundedness of the solution or some type of decay condition on the solution to zero as $x \rightarrow \pm\infty$. In mathematics, a pure initial value problem like (2.1)–(2.2) is often called a **Cauchy problem**.

Deriving the solution of (2.1)–(2.2) can be accomplished in two steps. First we solve the problem for a step function $\phi(x)$, and then we construct the solution to (2.1)–(2.2) using that solution. Therefore, let us consider the problem

$$w_t = kw_{xx}, \quad x \in \mathbb{R}, \quad t > 0, \quad (2.3)$$

$$w(x, 0) = 0 \quad \text{for } x < 0; \quad w(x, 0) = u_0 \quad \text{for } x > 0, \quad (2.4)$$

where we have taken the initial condition to be a step function with jump u_0 .

We motivate our approach with a simple idea from the subject of dimensional analysis. Dimensional analysis deals with the study of units (seconds, meters, kilograms, and so forth) and dimensions (time, length, mass, and so forth) of the quantities in a problem and how they relate to each other. Equations must be dimensionally consistent (one cannot add apples to oranges), and important conclusions can be drawn from this fact. The cornerstone result in dimensional analysis is called the *pi theorem*. The pi theorem guarantees that whenever there is a physical law relating dimensioned quantities q_1, \dots, q_m , then there is an equivalent physical law relating the independent dimensionless quantities that can be formed from q_1, \dots, q_m . By a dimensionless quantity we mean one in which all the dimensions (length, time, mass, etc.) cancel out. For a simple example take the law

$$h = -\frac{1}{2}gt^2 + vt,$$

which gives the height h of an object at time t when it is thrown upward with initial velocity v ; the constant g is the acceleration due to gravity. Here the dimensioned quantities are h , t , v , and g , having dimensions length, time, length per time, and length per time-squared. This law can be rearranged and written equivalently as

$$\frac{h}{vt} = -\frac{1}{2} \left(\frac{gt}{v} \right) + 1$$

in terms of the two dimensionless quantities

$$\pi_1 \equiv \frac{h}{vt} \quad \text{and} \quad \pi_2 \equiv \frac{gt}{v}.$$

For example, h is a length and vt , a velocity times a time, is also a length; so π_1 , or h divided by vt , has no dimensions. Similarly, $\pi_2 = gt/v$ is dimensionless.

A law in dimensioned variables can always be reformulated in dimensionless quantities. So the physical law can be written as $\pi_1 = -\frac{1}{2}\pi_2 + 1$.

We use similar reasoning to guess the form of the solution of the initial value problem (2.3)–(2.4). First we list all the variables and constants in the problem: x, t, w, u_0, k . These have dimensions length, time, degrees, degrees, and length-squared per time, respectively. We notice that w/u_0 is a dimensionless quantity (degrees divided by degrees); the only other independent dimensionless quantity in the problem is $x/\sqrt{4kt}$ (the “4” is included for convenience). By the pi theorem we expect that the solution can be written as some combination of these dimensionless variables, or

$$\frac{w}{u_0} = f\left(\frac{x}{\sqrt{4kt}}\right)$$

for some function f yet to be determined. In fact, this is the case. So let us substitute

$$w = f(z), \quad z = \frac{x}{\sqrt{4kt}}$$

into the PDE (2.3). We have taken $u_0 = 1$ for simplicity. The chain rule allows us to compute the partial derivatives as

$$\begin{aligned} w_t &= f'(z)z_t = -\frac{1}{2}\frac{x}{\sqrt{4kt^3}}f'(z), \\ w_x &= f'(z)z_x = \frac{1}{\sqrt{4kt}}f'(z), \\ w_{xx} &= \frac{\partial}{\partial x}w_x = \frac{1}{4kt}f''(z). \end{aligned}$$

Substituting into (2.3) gives, after some cancelation, an ordinary differential equation,

$$f''(z) + 2zf'(z) = 0,$$

for $f(z)$. This equation is easily solved by multiplying through by the integrating factor e^{z^2} and integrating to get

$$f'(z) = c_1 e^{-z^2},$$

where c_1 is a constant of integration. Integrating from 0 to z gives

$$f(z) = c_1 \int_0^z e^{-r^2} dr + c_2,$$

where c_2 is another constant of integration. Therefore we have determined solutions of (2.3) of the form

$$w(x, t) = c_1 \int_0^{x/\sqrt{4kt}} e^{-r^2} dr + c_2.$$

Next we apply the initial condition (2.4) (taking $u_0 = 1$) to determine the constants c_1 and c_2 . For a fixed $x < 0$ we take the limit as $t \rightarrow 0$ to get

$$0 = w(x, 0) = c_1 \int_0^{-\infty} e^{-r^2} dr + c_2.$$

For a fixed $x > 0$ we take the limit as $t \rightarrow 0$ to get

$$1 = w(x, 0) = c_1 \int_0^{\infty} e^{-r^2} dr + c_2.$$

Recalling that

$$\int_0^{\infty} e^{-r^2} dr = \frac{\sqrt{\pi}}{2},$$

we can solve the last two equations to get $c_1 = 1/\sqrt{\pi}$, $c_2 = 1/2$. Therefore, the solution to (2.3)–(2.4) with $u_0 = 1$ is

$$w(x, t) = \frac{1}{2} + \frac{1}{\sqrt{\pi}} \int_0^{x/\sqrt{4kt}} e^{-r^2} dr. \quad (2.5)$$

This solution can be written nicely as

$$w(x, t) = \frac{1}{2} \left(1 + \operatorname{erf} \left(\frac{x}{\sqrt{4kt}} \right) \right) \quad (2.6)$$

in terms of a special function called the “erf” function, which is defined by

$$\operatorname{erf}(z) = \frac{2}{\sqrt{\pi}} \int_0^z e^{-r^2} dr.$$

Figure 2.1 shows a graph of several time snapshots of the solution (2.6).

Now we will use (2.5) and a physical argument to deduce a solution to the Cauchy problem (2.1)–(2.2). Later, in Section 2.7, we present an analytical argument based on Fourier transforms. We make some observations. First, if a function w satisfies the heat equation, then so does w_x , the partial derivative of that function with respect to x . This is easy to see because

$$0 = (w_t - kw_{xx})_x = (w_x)_t - k(w_x)_{xx}.$$

Therefore, since $w(x, t)$ solves the heat equation, the function

$$G(x, t) \equiv w_x(x, t)$$

solves the heat equation. By direct differentiation of $w(x, t)$ we find that

$$G(x, t) = \frac{1}{\sqrt{4\pi kt}} e^{-x^2/(4kt)}. \quad (2.7)$$

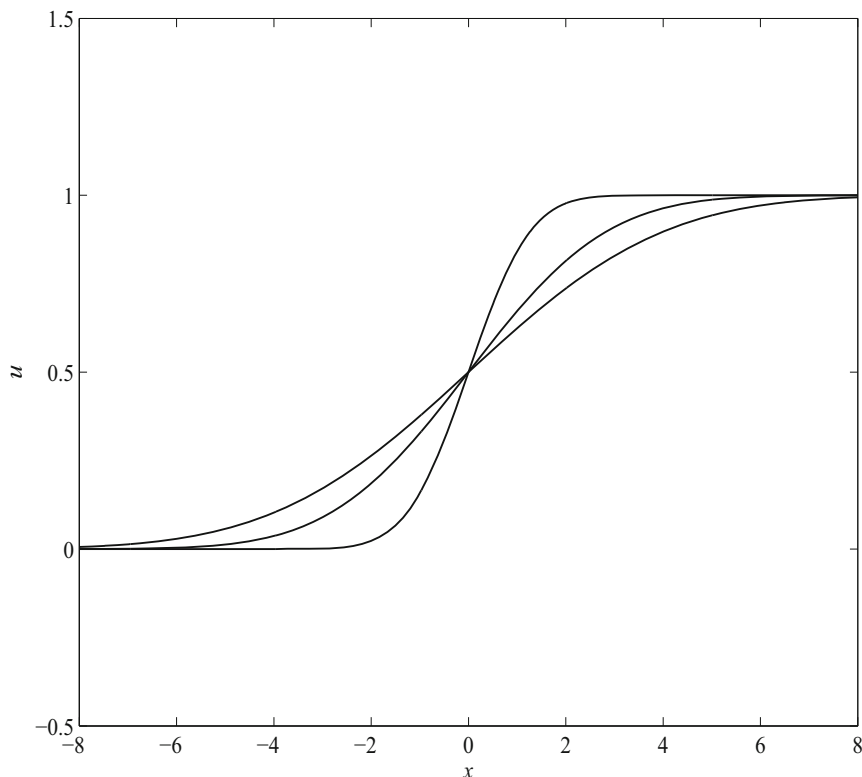

Figure 2.1 Temperature profiles $u = \frac{1}{2} \left(1 + \operatorname{erf} \left(\frac{x}{\sqrt{4kt}} \right) \right)$ at three different times t when the initial temperature is a step function and $k = 1$. As time increases, the profiles are smearing out

The function G is called the **heat kernel** or **fundamental solution** to the heat equation; the reader will note that for each $t > 0$ it graphs as a bell-shaped curve (see Exercise 1, Section 1.1), and the area under the curve for each $t > 0$ is one; that is,

$$\int_{-\infty}^{\infty} G(x, t) dx = 1, \quad t > 0.$$

$G(x, t)$ is the temperature surface that results from an initial unit heat source, i.e., injecting a unit amount of heat at $x = 0$ at time $t = 0$. We further observe that shifting the temperature profile again leads to a solution to the heat equation. Thus, $G(x - y, t)$, which is the temperature surface caused by an initial unit heat source at y , solves the heat equation for any fixed, but arbitrary, y . If $\phi(y)$, rather than unity, is the magnitude of the source at y , then $\phi(y)G(x - y, t)$ gives the resulting temperature surface; the area under a

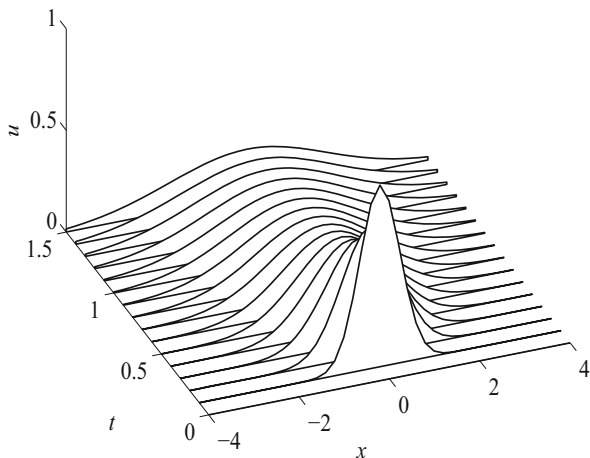

Figure 2.2 Plot of the fundamental solution $u = G(x, t)$ to the diffusion equation (2.7). As $t \rightarrow 0^+$ the solution approaches a unit ‘point source’ at $t = 0$

temperature profile is now $\phi(y)$, where y is the location of the source. Now, let us regard the initial temperature function ϕ in (2.2) as a continuous distribution of sources $\phi(y)$ for each $y \in \mathbb{R}$. Then, superimposing all the effects $\phi(y)G(x - y, t)$ for all y gives the total effect of all these isolated sources; that is,

$$\begin{aligned} u(x, t) &= \int_{-\infty}^{\infty} \phi(y)G(x - y, t)dy \\ &= \int_{-\infty}^{\infty} \phi(y)\frac{1}{\sqrt{4\pi kt}}e^{-(x-y)^2/(4kt)}dy \end{aligned}$$

is a solution to the Cauchy problem (2.1)–(2.2) for reasonable assumptions on the initial condition ϕ . More precisely:

Theorem 2.1

Consider the initial value problem for the heat equation,

$$\begin{aligned} u_t &= ku_{xx}, \quad x \in \mathbb{R}, \quad t > 0, \\ u(x, 0) &= \phi(x), \quad x \in \mathbb{R}, \end{aligned}$$

where ϕ is a bounded continuous function on \mathbb{R} . Then

$$u(x, t) = \int_{-\infty}^{\infty} \phi(y)\frac{1}{\sqrt{4\pi kt}}e^{-(x-y)^2/(4kt)}dy \quad (2.8)$$

is a solution to the heat equation for $x \in \mathbb{R}$, $t > 0$, and it has the property that $u(x, t) \rightarrow \phi(x)$ as $t \rightarrow 0^+$. If ϕ is piecewise continuous, i.e., it has only finitely many jump discontinuities in any bounded interval, then $u(x, t)$ is a solution to the heat equation on $x \in \mathbb{R}$, $t > 0$; and, as $t \rightarrow 0^+$, the solution approaches the average value of the left and right limits at a point of discontinuity of ϕ ; in symbols,

$$u(x, t) \rightarrow \frac{1}{2} (\phi(x^-) + \phi(x^+)) \text{ as } t \rightarrow 0^+. \quad \square$$

This discussion of the Cauchy problem for the heat equation has been intuitive, and it provides a good basis for understanding why the solution has the form it does.

There is another, standard way to write the solution (2.8) to the Cauchy problem (2.1)–(2.2). If we change variables in the integral using the substitution $r = (x - y)/\sqrt{4kt}$, then $dr = -dy/\sqrt{4kt}$, and (2.8) becomes

$$u(x, t) = \frac{1}{\sqrt{\pi}} \int_{-\infty}^{\infty} e^{-r^2} \phi(x - r\sqrt{4kt}) dr. \quad (2.9)$$

This formula is called the **Poisson integral representation**.

We make several observations. First, the solution of the Cauchy problem is an integral representation. Although the formula is not complicated, for most initial conditions $\phi(x)$ the integration cannot be performed analytically. Therefore, numerical or computer evaluation of the integral is ultimately required if temperature profiles are desired. Also, notice that the temperature $u(x, t)$ is nonzero for every real x , even if ϕ is zero outside a small interval about the origin. Thus, a signal propagated by the heat, or diffusion, equation travels infinitely fast; according to this model, if odors diffuse, a bear would instantly smell a newly opened can of tuna ten miles away. Next, although we do not give a proof, the solution given by (2.8) is very smooth; that is, u is infinitely differentiable in both x and t in the domain $t > 0$; this is true even if ϕ is piecewise continuous. Initial signals propagated by the heat equation are immediately smoothed out.

Finally, we note that the heat kernel $G(x, t)$ defined in (2.7) is also called the **Green's function** for the Cauchy problem. In general, the Green's function for a problem is the response of a system, or the effect, caused by a point source. In heat flow on the real line, $G(x, t)$ is the response, i.e., the temperature surface caused by a unit, point heat source given to the system at $x = 0$, $t = 0$. Some of the references discuss the construction of a Green's functions for a variety of problems. Because of the basic role this function plays in diffusion problems, $G(x, t)$ is also called the **fundamental solution** to the heat equation. The reader should review Section 1.4 for a discussion of the origin of the fundamental solution from a probability discussion.

EXERCISES

1. Solve the Cauchy problem (2.1)–(2.2) for the following initial conditions.

a) $\phi(x) = 1$ if $|x| < 1$ and $\phi(x) = 0$ if $|x| > 1$.

b) $\phi(x) = e^{-x}$, $x > 0$; $\phi(x) = 0$, $x < 0$.

In both cases write the solutions in terms of the erf function. Hint: In (b) complete the square with respect to y in the exponent of e .

2. If $|\phi(x)| \leq M$ for all x , where M is a positive constant, show that the solution u to the Cauchy problem (2.1)–(2.2) satisfies $|u(x, t)| \leq M$ for all x and $t > 0$. Hint: Use the calculus fact that the absolute value of an integral is less than or equal to the integral of the absolute value: $|\int f| \leq \int |f|$.

3. Consider the problem (2.3)–(2.4) with $u_0 = 1$. For a fixed $x = x_0$, what is the approximate temperature $w(x_0, t)$ for very large t ? Hint: Expand the integrand in the formula for the solution in a power series and integrate term by term.

4. Show that if $u(x, t)$ and $v(x, t)$ are any two solutions to the heat equation (2.1), then $w(x, y, t) = u(x, t)v(y, t)$ solves the two-dimensional heat equation $w_t = k(w_{xx} + w_{yy})$. Can you guess the solution to the two-dimensional Cauchy problem

$$\begin{aligned} w_t &= k(w_{xx} + w_{yy}), \quad (x, y) \in \mathbb{R}^2, \quad t > 0, \\ w(x, y, 0) &= \psi(x, y), \quad (x, y) \in \mathbb{R}^2? \end{aligned}$$

5. Let the initial temperature in the Cauchy problem (2.1)–(2.2) be given by $\phi(x) = e^{-|x+2|} + e^{-|x-2|}$, with $k = 1$. Use the numerical integration operation in a computer algebra package to draw temperature profiles at several times to illustrate how heat flows in this system. Exhibit the temperature profiles on a single set of coordinate axes.

6. Verify that

$$\int_{-\infty}^{\infty} G(x, t) dx = 1, \quad t > 0.$$

Hint: Change variables as in the derivation of Poisson's integral representation.

7. Consider the Cauchy problem for the heat equation

$$u_t = k u_{xx}, \quad x \in \mathbb{R}, \quad t > 0; \quad u(x, 0) = e^{-x}, \quad x \in \mathbb{R}.$$

Verify that $u(x, t) = e^{-x+kt}$ is an unbounded solution. Is this a contradiction to the theorem?

2.2 Cauchy Problem for the Wave Equation

The one-dimensional wave equation is

$$u_{tt} - c^2 u_{xx} = 0. \quad (2.10)$$

We observed in Section 1.5 that it models the amplitude of transverse displacement waves on a taut string as well as small amplitude disturbances in acoustics. It also arises in electromagnetic wave propagation, in the mechanical vibrations of elastic media, as well as in other problems. It is a hyperbolic equation and is one of the three fundamental equations in PDEs (along with the diffusion equation and Laplace's equation). Under the transformation of variables (to characteristic coordinates)

$$\xi = x - ct, \quad \tau = x + ct,$$

the wave equation is transformed into the canonical form

$$U_{\tau\xi} = 0, \quad U = U(\xi, \tau),$$

which can be integrated twice to obtain the general solution

$$U(\xi, \tau) = F(\xi) + G(\tau),$$

where F and G are arbitrary functions. Thus, the general solution to (2.10) is

$$u(x, t) = F(x - ct) + G(x + ct). \quad (2.11)$$

Hence, solutions of the wave equation are the superposition (sum) of right- and left-traveling waves moving at speed c .

The Cauchy problem for the wave equation is

$$u_{tt} - c^2 u_{xx} = 0, \quad x \in \mathbb{R}, t > 0, \quad (2.12)$$

$$u(x, 0) = f(x), \quad u_t(x, 0) = g(x), \quad x \in \mathbb{R}. \quad (2.13)$$

Here, f defines the initial displacement of an infinite string, and g defines its initial velocity. The equation is second-order in t , so both the position and velocity must be specified initially.

There is a simple analytical formula for the solution to the Cauchy problem (2.12)–(2.13). It is called **d'Alembert's formula**, and it is given by

$$u(x, t) = \frac{1}{2}(f(x - ct) + f(x + ct)) + \frac{1}{2c} \int_{x-ct}^{x+ct} g(s) ds. \quad (2.14)$$

If f'' and g' are continuous, then it is a straightforward exercise in differential calculus, using Leibniz's formula, to verify that this formula solves (2.12)–(2.13). The formula can be derived (see Exercise 1) by determining the two functions F and G in (2.11) using the initial data (2.13).

Example 2.2

Insight into the behavior of solutions comes from examining the special case where the initial velocity is zero and the initial displacement is a bell-shaped curve. Specifically, we consider the problem (with $c = 2$)

$$\begin{aligned} u_{tt} - 4u_{xx} &= 0, \quad x \in \mathbb{R}, t > 0, \\ u(x, 0) &= e^{-x^2}, \quad u_t(x, 0) = 0, \quad x \in \mathbb{R}. \end{aligned}$$

The exact solution is, by d'Alembert's formula,

$$u(x, t) = \frac{1}{2}(e^{-(x-2t)^2} + e^{-(x+2t)^2}).$$

Either the solution surface or wave profiles can be graphed easily using a computer algebra package. Figure 2.3 shows the solution surface; observe how the initial signal at $t = 0$ splits into two smaller signals, and those travel off in opposite directions at speed $c = 2$. In the exercises the reader is asked to examine the case where $f = 0$ and $g \neq 0$; this is the case where the initial displacement is zero and the string is given an initial velocity, or impulse, by, say, striking the string with an object. \square

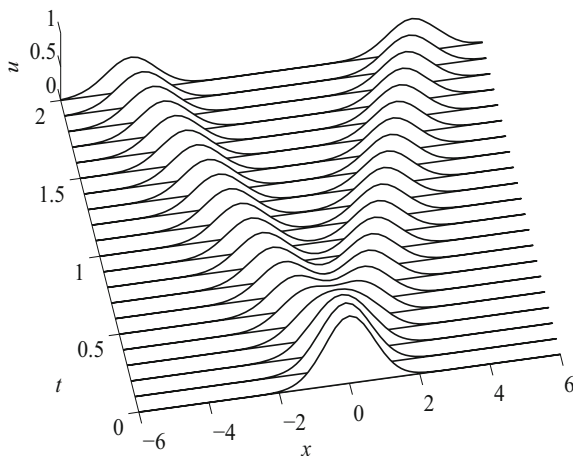

Figure 2.3 Time profiles of the solution surface. The initial signal splits into two signals which move at speeds c and $-c$ along the positive and negative characteristics, $x - ct = \text{const.}$, $x + ct = \text{const.}$, respectively

Close examination of d'Alembert's formula reveals a fundamental property of the wave equation. If the initial disturbance is *supported* in some interval

$a \leq x \leq b$ (this means that it is zero outside that interval, so the signal is located only in $a \leq x \leq b$), then the signal is always zero outside the region bounded by the two straight lines $x + ct = a$ and $x - ct = b$. See Figure 2.4.

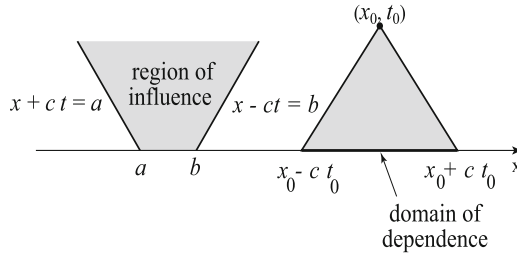

Figure 2.4 Region of influence and domain of dependence

This region is called the **region of influence** of the interval $[a, b]$. An initial signal in $[a, b]$ can never affect the solution outside this region. The lines $x + ct = \text{constant}$ are paths in space–time along which signals are propagated at velocity $-c$; the lines $x - ct = \text{constant}$ are paths in space–time along which signals are propagated with velocity c . These two families of lines are called the **negative** and **positive characteristics**, respectively. If the interval $[a, b]$ is shrunk to a point, then the region of influence shrinks to a cone, which is called the *light cone*. Looking at the situation in reverse, we can ask what initial data can affect the solution at a point (x_0, t_0) . From the d’Alembert formula, only the initial values in the interval $[x_0 - ct_0, x_0 + ct_0]$ will affect the solution at (x_0, t_0) . This interval is called the **domain of dependence**, and it is found by tracing the characteristics emanating from the point (x_0, t_0) backward in time to the x -axis.

In summary, there are important points to note regarding the characteristic curves. First, they are curves that carry the signals forward in space–time with velocity c and $-c$. Second, they define a special coordinate system $\xi = x - ct$, $\tau = x + ct$ under which the wave equation $u_{tt} - c^2 u_{xx} = 0$ is reduced to the simple canonical form $u_{\xi\tau} = 0$. In hyperbolic problems there is always a set of characteristic curves that play these roles. Even first order PDEs, which are actually wave-like, have one family of such curves that carry signals and provide a distinguished coordinate system where the problem simplifies (recall the examples in Section 1.2).

Finally, we point out again the important differences between parabolic and hyperbolic problems. Hyperbolic, or wave-like, equations propagate signals at a finite speed along characteristics; there is coherency in the wave form as

it propagates, and therefore information is retained. Parabolic, or diffusion, equations propagate signals at infinite speed; because the signals diffuse or smear out, there is a gradual loss of information. A good way to understand how different equations propagate information is to determine how a signal is propagated in a special case. For example, suppose the initial signal is a Gaussian function or bell-shaped curve $\exp(-x^2)$. Think of this signal as being a bit of information. The convection equation $u_t + cu_x = 0$, which is a wave-like equation, propagates this signal via

$$u(x, t) = e^{-(x-ct)^2}.$$

That is, it moves it at speed c without distortion. The wave equation $u_{tt} = c^2 u_{xx}$ moves it via

$$u(x, t) = 0.5(e^{-(x-ct)^2} + e^{-(x+ct)^2}).$$

So the signal breaks into two pieces, and they propagate in opposite directions at speed c . The diffusion equation $u_t = k u_{xx}$ propagates the signal via

$$u(x, t) = \frac{1}{\sqrt{1+4kt}} e^{-x^2/(1+4kt)}.$$

So the signal stays at the same place, but it spreads out and decreases in amplitude. Any information in the signal is eventually lost.

EXERCISES

1. Derive d'Alembert's formula (2.14) by determining the two arbitrary functions F and G in the general solution (2.11) using the initial conditions (2.13).
2. Calculate the exact solution to the Cauchy problem when $c = 2$, the initial displacement is $f(x) = 0$, and the initial velocity is $g(x) = 1/(1 + 0.25x^2)$. Plot the solution surface and discuss the effect of giving a string at rest an initial impulse. Contrast the solution with the case when $f \neq 0$ and $g = 0$.
3. Solve the Cauchy problem

$$u_{tt} = c^2 u_{xx}, \quad u(x, 0) = \phi(x), \quad u_t(x, 0) = 0,$$

by differentiating the solution to the Cauchy problem

$$u_{tt} = c^2 u_{xx}, \quad u(x, 0) = 0, \quad u_t(x, 0) = \phi(x).$$

4. Solve the outgoing signal problem

$$u_{tt} - c^2 u_{xx} = 0, \quad x > 0, \quad -\infty < t < \infty; \quad u_x(0, t) = s(t), \quad -\infty < t < \infty,$$

where $s(t)$ is a known signal. Hint: Look for a right-traveling wave solution.

5. The three-dimensional wave equation is

$$u_{tt} - c^2 \Delta u = 0,$$

where $u = u(x, y, z, t)$ and Δ is the Laplacian operator. For waves with spherical symmetry, $u = u(\rho, t)$, where $\rho = \sqrt{x^2 + y^2 + z^2}$. In this special case the Laplacian is given by (Section 1.8) $\Delta u = u_{\rho\rho} + \frac{2}{\rho}u_{\rho}$. By introducing a change of dependent variable $U = \rho u$, show that the general solution for the spherically symmetric wave equation

$$u_{tt} = c^2(u_{\rho\rho} + \frac{2}{\rho}u_{\rho})$$

is

$$u = \frac{1}{\rho}(F(\rho - ct) + G(\rho + ct)).$$

Why do you think an outward-moving wave $u = F(\rho - ct)/\rho$ decays in amplitude? Give a physical interpretation.

6. Solve the Cauchy problem

$$\begin{aligned} u_{tt} - c^2 u_{xx} &= 0, \quad x \in \mathbb{R}, \quad t > 0, \\ u(x, 0) &= e^{-|x|}, \quad u_t(x, 0) = \cos x, \quad x \in \mathbb{R}. \end{aligned}$$

Use a computer algebra program to graph wave profiles at $t = 1, 2, 3$. Take $c = 1$.

7. In Section 1.7 we showed that any solution to Laplace's equation has the property that its value at a point is approximately the average of four nearby values surrounding the point. Can we make a statement about solutions to the wave equation? Consider any characteristic parallelogram (see Figure 2.5) whose sides are positive and negative characteristics, and let A, B, C, D be the vertices as shown. Show that any solution to the wave equation satisfies the relation

$$u(A) + u(C) = u(B) + u(D).$$

8. Let $u = u(x, t)$ solve the wave equation; show that $v = v(x, t)$ defined by

$$v(x, t) = \frac{c}{\sqrt{4\pi kt}} \int_{-\infty}^{\infty} u(s, x) e^{-s^2 c^2 / (4kt)} ds.$$

solves the heat equation.

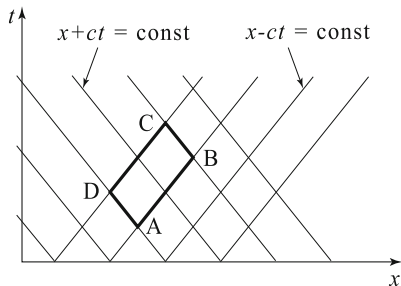

Figure 2.5 Characteristic parallelogram ABCD

9. Using the hint below and verifying the steps, find a particular solution to the nonhomogeneous wave equation

$$u_{tt} - c^2 u_{xx} = f(x, t), \quad x \in \mathbb{R}, \quad t > 0; \quad u(x, 0) = u_t(x, 0) = 0, \quad x \in \mathbb{R}.$$

Hint: Integrate the equation over the characteristic triangle T with corners $(\xi - c\tau, 0)$, $(\xi + c\tau, 0)$, (ξ, τ) to get

$$\begin{aligned} \int \int_T f \, dx dt &= \int_T (u_{tt} - c^2 u_{xx}) \, dx dt \\ &= \int_C -c^2 u_x \, dt - u_t \, dx \quad (\text{by Green's Theorem}) \\ &= 2cu(\xi, \tau). \end{aligned}$$

This gives the solution at any point (ξ, τ) . Here, C is the boundary of T .

2.3 Well-Posed Problems

In the last two sections we solved the Cauchy problem, or pure initial value problem, for the heat equation and for the wave equation. Now let us set up a similar problem for Laplace's equation. Immediately the reader should be skeptical because Laplace's equation is an elliptic equilibrium equation that does not involve time; we expect boundary conditions rather than initial conditions. Nevertheless, let us consider the two-dimensional Laplace's equation in the upper-half plane $y > 0$ and prescribe u and its y derivative u_y along $y = 0$, or the x axis. That is, let us consider the problem

$$u_{xx} + u_{yy} = 0, \quad x \in \mathbb{R}, \quad y > 0, \tag{2.15}$$

$$u(x, 0) = f(x), \quad u_y(x, 0) = g(x), \quad x \in \mathbb{R}. \tag{2.16}$$

Notice the similarity to the initial value problem for the wave equation (2.12)–(2.13); but here we are using y instead of t , and the equation is elliptic rather than hyperbolic. As an aside, observe that (2.15)–(2.16) is neither a Dirichlet problem nor a Neumann problem because both u and u_y are specified along the boundary $y = 0$.

Let us carefully analyze problem (2.15)–(2.16) in a special case. Suppose first that the boundary conditions are

$$f(x) = g(x) = 0.$$

Then it is clear that a solution (the only solution) to (2.15)–(2.16) is the zero solution $u(x, y) \equiv 0$ for all $x \in \mathbb{R}$, $y > 0$. Now let us change the conditions along the boundary by taking

$$f(x) = \frac{1}{n} \cos nx, \quad g(x) = 0, \quad x \in \mathbb{R}.$$

Then, as one can easily check, the solution to (2.15)–(2.16) is

$$u(x, y) = \frac{1}{n} \cos nx \cosh ny.$$

Suppose n is large (say $n = 100$); then we have changed the boundary condition $u(x, 0) = f(x)$ by only a small amount. Yet the solution has changed from zero by a large amount! For example, along the line $x = 0$ (y axis) the solution is

$$u(0, y) = \frac{\cosh ny}{n} \rightarrow +\infty \text{ as } y \rightarrow \infty.$$

To summarize, in this problem a small change of the data on the boundary produced a large change in the solution. This behavior is disturbing, because in a physical problem we expect that the solution should depend continuously on the boundary data—a small change in the boundary data should produce a small change in the solution. After all, we want to be confident in the accuracy of our solution even if we get the boundary data only approximately correct. This latter property of continuous dependence on data is called **stability**, and the problem (2.15)–(2.16) does not have it. So the Cauchy problem for Laplace's equations (2.15)–(2.16) is *not* a well-posed physical problem. In fact, since Laplace's equation models steady heat flow, it seems physically reasonable that we need only specify the temperature $u(x, 0)$ along the boundary to be able to solve the problem, or specify the flux $u_y(x, 0)$, but not both as in (2.16).

The term well-posed in PDEs has a technical meaning. We say that a boundary value problem, initial value problem, or an initial boundary value problem is **well-posed** if:

- (1) (**Existence**) it has a solution
- (2) (**Uniqueness**) the solution is unique
- (3) (**Stability**) the solution depends continuously on the initial and/or boundary data.

If a problem is not well-posed, then it is called **ill-posed**. Resolving these three issues for various PDE models occupies much of the theory of PDEs.

Now that we have shown that the Cauchy problem for Laplace's equation is not stable, the reader may be skeptical about other problems such as the Cauchy problem for the heat equation. We can easily observe that solutions to this problem have the stability property.

Example 2.3

Consider the two problems

$$\begin{aligned}u_t &= ku_{xx}, \quad x \in \mathbb{R}, \quad t > 0, \\u(x, 0) &= \phi(x), \quad x \in \mathbb{R},\end{aligned}$$

and

$$\begin{aligned}v_t &= kv_{xx}, \quad x \in \mathbb{R}, \quad t > 0, \\v(x, 0) &= \psi(x), \quad x \in \mathbb{R},\end{aligned}$$

where ϕ and ψ are continuous, bounded functions and close in the sense that $|\phi(x) - \psi(x)| \leq \delta$ for all x , where δ is a small number. We would like to show that the corresponding solutions $u(x, t)$ and $v(x, t)$ are close. We define $w(x, t) = u(x, t) - v(x, t)$ and note that w satisfies the Cauchy problem

$$\begin{aligned}w_t &= kw_{xx}, \quad x \in \mathbb{R}, \quad t > 0, \\w(x, 0) &= \phi(x) - \psi(x), \quad x \in \mathbb{R}.\end{aligned}$$

The solution formula for the Cauchy problem gives

$$w(x, t) = \int_{-\infty}^{\infty} (\phi(y) - \psi(y))G(x - y, t)dy,$$

where $G(x, t)$ is the fundamental solution. Therefore, for each $t > 0$,

$$\begin{aligned}|u(x, t) - v(x, t)| &\leq \int_{-\infty}^{\infty} |\phi(y) - \psi(y)| |G(x - y, t)| dy \\&\leq \int_{-\infty}^{\infty} \delta G(x - y, t)dy = \delta,\end{aligned}$$

since $\int G(x-y, t) dy = 1$. Therefore, in the sense interpreted above, closeness of the initial data implies closeness of the solution. \square

EXERCISES

1. Show that the Cauchy problem for the *backward* diffusion equation,

$$\begin{aligned} u_t + u_{xx} &= 0, & x \in \mathbb{R}, t > 0, \\ u(x, 0) &= f(x), & x \in \mathbb{R}, \end{aligned}$$

is unstable by considering the solutions

$$u(x, t) = 1 + \frac{1}{n} e^{n^2 t} \sin nx$$

for large n . Hint: Follow the method used in this section for Laplace's equation.

2. Let $u = u(x, y)$. Is the problem

$$u_{xy} = 0, \quad 0 < x, y < 1,$$

on the unit square, where the value of u is prescribed on the boundary of the square, a well-posed problem? Discuss fully.

3. Consider the two Cauchy problems for the wave equation with different initial data:

$$\begin{aligned} u_{tt}^i &= c^2 u_{xx}^i, & x \in \mathbb{R}, \quad 0 < t < T, \\ u^i(x, 0) &= f^i(x), & u_t^i(x, 0) &= g^i(x), & x \in \mathbb{R}, \end{aligned}$$

for $i = 1, 2$, where f^1, f^2, g^1 , and g^2 are given functions (the superscripts are indices and not exponents). If for all $x \in \mathbb{R}$ we have

$$|f^1(x) - f^2(x)| \leq \delta_1, \quad |g^1(x) - g^2(x)| \leq \delta_2,$$

show that $|u^1(x, t) - u^2(x, t)| \leq \delta_1 + \delta_2 T$ for all $x \in \mathbb{R}, 0 < t < T$. What does this mean with regard to stability? Hint: Follow the method in Example 2.3.

2.4 Semi-Infinite Domains

Heat Equation

In Sections 2.1 and 2.2 we solved the heat equation and the wave equation, respectively, on the domain $-\infty < x < \infty$. Now we study these equations when the domain is semi-infinite, i.e., on the interval $0 < x < \infty$. This means that there is a boundary in the problem, at $x = 0$, and one expects that it is necessary to impose a boundary condition there. For example, to determine how the temperature distribution evolves in a semi-infinite bar, one should know the temperature in the bar initially, as well as the temperature at $x = 0$ for all time.

To begin, we consider the initial boundary value problem for the heat equation

$$u_t = ku_{xx}, \quad x > 0, t > 0, \quad (2.17)$$

$$u(0, t) = 0, \quad t > 0, \quad (2.18)$$

$$u(x, 0) = \phi(x), \quad x > 0, \quad (2.19)$$

where we specify the temperature to be zero at $x = 0$ for all time. To solve this problem we use the method of *reflection* through the boundary. The idea is to extend the problem (2.17)–(2.19) to the entire real axis by extending the initial data ϕ to an *odd function* ψ defined by

$$\psi(x) = \begin{cases} \phi(x), & x > 0, \\ -\phi(-x), & x < 0, \end{cases}$$

with $\psi(0) = 0$. We then solve the extended problem by formula (2.8) and then restrict that solution to the positive real axis, which will then be the solution to (2.17)–(2.19). Figure 2.6 shows the initial data for the *extended* problem and a resulting odd solution profile $v(x, t)$. Physically, we are attaching a bar occupying the space $-\infty < x < 0$ and giving it an initial temperature equal to the negative of that in the original bar. Thus, let us consider the Cauchy problem for $v(x, t)$:

$$v_t = kv_{xx}, \quad x \in \mathbb{R}, t > 0, \quad (2.20)$$

$$v(x, 0) = \psi(x), \quad x \in \mathbb{R}, \quad (2.21)$$

where ψ is the odd extension of the function ϕ as described above. By the formula for the solution to the heat equation over the real line, the solution to (2.20)–(2.21) is given by

$$v(x, t) = \int_{-\infty}^{\infty} G(x - y, t)\psi(y)dy,$$

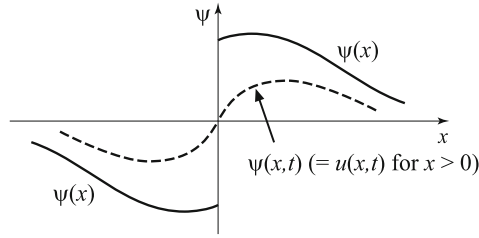

Figure 2.6 The initial data $\psi(x)$ and solution profile $v(x, t)$ for the odd, extended problem

where $G(x, y)$ is the fundamental solution. Breaking this integral into two parts, $y < 0$ and $y > 0$, we obtain

$$\begin{aligned}
 v(x, t) &= \int_{-\infty}^0 G(x-y, t)\psi(y)dy + \int_0^{\infty} G(x-y, t)\psi(y)dy \\
 &= -\int_{-\infty}^0 G(x-y, t)\phi(-y)dy + \int_0^{\infty} G(x-y, t)\phi(y)dy \\
 &= -\int_0^{\infty} G(x+y, t)\phi(y)dy + \int_0^{\infty} G(x-y, t)\phi(y)dy \\
 &= \int_0^{\infty} [G(x-y, t) - G(x+y, t)]\phi(y)dy.
 \end{aligned}$$

We restrict this solution to $x > 0$, and therefore the solution to the heat equations (2.17)–(2.19), on the domain $x \geq 0$, is

$$u(x, t) = \int_0^{\infty} [G(x-y, t) - G(x+y, t)]\phi(y)dy, \quad x \geq 0.$$

The Wave Equation

The wave equation on a semi-infinite domain can be solved in the same manner. Consider the problem of the transverse vibrations of a string occupying $x > 0$ when the end at $x = 0$ is held fixed. The initial boundary value problem is

$$u_{tt} = c^2 u_{xx}, \quad x > 0, t > 0, \quad (2.22)$$

$$u(0, t) = 0, \quad t > 0, \quad (2.23)$$

$$u(x, 0) = f(x), \quad u_t(x, 0) = g(x), \quad x > 0. \quad (2.24)$$

For $x > ct$ (i.e., ahead of the leading signal $x = ct$ coming from the origin) the interval of dependence lies in $(0, \infty)$, where the initial data are given; therefore, in this domain, the solution is given by d'Alembert's formula:

$$u(x, t) = \frac{1}{2}(f(x - ct) + f(x + ct)) + \frac{1}{2c} \int_{x-ct}^{x+ct} g(s) ds, \quad x > ct. \quad (2.25)$$

Next, the data given along the $x = 0$ boundary cannot affect the solution in the region $x > ct$, since signals travel outward from the boundary at speed c . See Figure 2.7 To solve the problem in the region $0 < x < ct$ we proceed as we

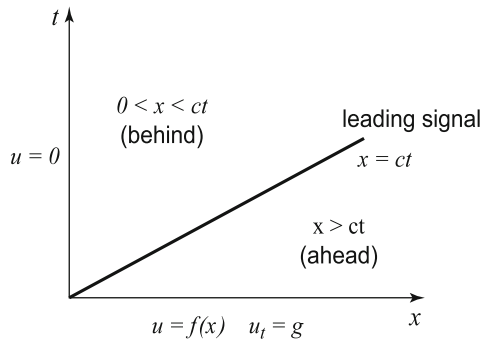

Figure 2.7 Space–time domain $x, t > 0$ where the problem (2.22)–(2.24) is defined. The region $x > ct$ is affected only by the initial data f and g and can be found by d'Alembert's formula

did for the heat equation and extend the initial data f and g to *odd* functions on the entire real axis. Therefore, we consider the problem

$$v_{tt} = c^2 v_{xx}, \quad x \in \mathbb{R}, t > 0, \quad (2.26)$$

$$v(0, t) = 0, \quad t > 0, \quad (2.27)$$

$$v(x, 0) = F(x), \quad v_t(x, 0) = G(x), \quad x \in \mathbb{R}, \quad (2.28)$$

where

$$F(x) = f(x), \quad x > 0; \quad F(0) = 0; \quad F(x) = -f(-x), \quad x < 0,$$

and

$$G(x) = g(x), \quad x > 0; \quad G(0) = 0; \quad G(x) = -g(-x), \quad x < 0.$$

By d'Alembert's formula the solution to (2.26)–(2.28) is

$$v(x, t) = \frac{1}{2}(F(x - ct) + F(x + ct)) + \frac{1}{2c} \int_{x-ct}^{x+ct} G(s) ds.$$

In the region $x < ct$ this becomes (since $x - ct < 0$)

$$v(x, t) = \frac{1}{2}(-f(-x + ct) + f(x + ct)) + \frac{1}{2c} \int_{x-ct}^0 -g(-s)ds \\ + \frac{1}{2c} \int_0^{x+ct} g(s)ds.$$

If the variable of integration s in the first integral is replaced by $-s$, then the two integrals can be combined, and we may write

$$u(x, t) = v(x, t) = \frac{1}{2}(f(x + ct) - f(ct - x)) + \frac{1}{2c} \int_{ct-x}^{ct+x} g(s)ds, \quad (2.29) \\ 0 < x < ct.$$

In summary, the solution to the initial boundary value problem (2.22)–(2.24) for the wave equation on a half-line is given by the two formulas (2.25) and (2.29), depending on $x > ct$ or $x < ct$.

Why does this reflection method work for the heat equation and wave equation? To reiterate, the solutions to the Cauchy problems for these two equations are odd functions if the initial data is odd. And the restriction of an odd solution to the positive real axis is the solution to the given initial boundary value problem. If this intuitive reasoning leaves the reader perplexed, then one can always verify analytically that the solutions we have obtained by this reflection method are, in fact, solutions to the given problems.

Finally, if the boundary condition (2.18) along $x = 0$ in the heat flow problem (2.17)–(2.19) is replaced by a Neumann condition

$$u_x(0, t) = 0, \quad t > 0,$$

then the problem can be solved by extending the initial data to an *even* function. The same is true for the wave equation. We leave these calculations as exercises.

EXERCISES

1. Solve the initial boundary value problem for the heat equation,

$$u_t = ku_{xx}, \quad x > 0, t > 0, \\ u_x(0, t) = 0, \quad t > 0, \\ u(x, 0) = \phi(x), \quad x > 0,$$

with an insulated boundary condition, by extending the initial temperature ϕ to the entire real axis as an *even* function. The solution is

$$u(x, y) = \int_0^\infty [G(x - y, t) + G(x + y, t)]\phi(y)dy.$$

2. Find a formula for the solution to the problem

$$\begin{aligned}u_t &= ku_{xx}, \quad x > 0, t > 0, \\u(0, t) &= 0, \quad t > 0, \\u(x, 0) &= 1, \quad x > 0.\end{aligned}$$

Plot several solution profiles when $k = 0.5$.

3. Find the solution to the problem

$$\begin{aligned}u_{tt} &= c^2 u_{xx}, \quad x > 0, t > 0, \\u(0, t) &= 0, \quad t > 0, \\u(x, 0) &= xe^{-x}, \quad u_t(x, 0) = 0, \quad x > 0.\end{aligned}$$

Pick $c = 0.5$ and sketch several time snapshots of the solution surface to observe the reflection of the wave from the boundary.

4. Solve the problem

$$\begin{aligned}u_t &= ku_{xx}, \quad x > 0, t > 0, \\u(0, t) &= 1, \quad t > 0, \\u(x, 0) &= 0, \quad x > 0.\end{aligned}$$

Hint: Transform the problem to one of the form (2.17)–(2.19) and use Exercise 2.

5. (Age of the earth) In this exercise we use Lord Kelvin's argument, given in the mid 1860s, to estimate the age of the earth using a measurement of the geothermal gradient at the surface. The geothermal gradient is the temperature gradient u_x measured at surface of the earth. To obtain the estimate, treat the earth as flat at the surface with $x > 0$ measuring the depth from the surface $x = 0$. Take the diffusivity of the earth to be $k = 0.007 \text{ cm}^2$ per second, the assume that initial temperature was 7000 degrees Fahrenheit (molten rock) at the beginning. Finally, assume the temperature of the surrounding atmosphere has always been 0 degrees. Use a current geothermal gradient value of 3.7×10^{-4} degrees per cm. After determining the approximate age of the earth, estimate the percentage of the original heat that has been lost until the present day? Comment on the accuracy of the Kelvin's argument by searching on line for the approximate age of the earth. Hint: Treat this as a linear, one-dimensional, heat flow problem.
6. (Subsurface temperatures) A clutch of insect eggs lies at a depth of x_1 cm below the ground surface.

- a) If the surface is subjected to periodic temperature variations of $T_0 + A \cos \omega t$ over a long time, what is the temperature variation experienced by the egg clutch? Hint: find a complex, plane wave solution of the diffusion equation of the form $u = T_0 + Ae^{i(\gamma x - \omega t)}$ and determine γ in terms of ω and the diffusivity k of the soil; take the real part.
- b) At depth x_1 find the phase shift of the temperature and the amplitude attenuation factor.
- c) Plot of the amplitude of the temperature variation versus depth. Take $T_0 = 30$, $A = 15$ degrees Celsius, $k = 0.004 \text{ cm}^2$ per second, and $\omega = 2\pi$ per day, and plot the temperature variations at the surface and at the depth 3 cm.
7. The heat equation governs the flow of heat downward ($x \geq 0$) through the soil due to changes in ambient air temperature $S(t)$ at the surface ($x = 0$) and the absorption of heat caused by solar radiation $W(t)$ falling on the surface, measured in Watts per unit area A , per time. Let $u = u(x, t)$ denote the temperature at a depth x at time, and let C , ρ , and K be the specific heat, density, and thermal conductivity of the soil. Also, let H denote the heat transfer coefficient at the surface and α be the fraction of solar energy that is absorbed at the surface. Derive the boundary condition at the surface,

$$-AKu_x(0, t) = -AH(u(0, t) - S(t)) + A\alpha W(t),$$

being specific about the origin of each term. Give a correct set of units for each quantity appearing. (For an example see A. Parrott & J. D. Logan, 2010, *Ecological Modelling* 221, 1378–1393.)

2.5 Sources and Duhamel's Principle

How do we proceed if the PDE contains a source term? For example, consider the heat-flow problem

$$u_t = ku_{xx} + f(x, t), \quad x \in \mathbb{R}, t > 0, \quad (2.30)$$

$$u(x, 0) = 0, \quad x \in \mathbb{R}, \quad (2.31)$$

where f is a given heat source. The key to the analysis of this problem can be discovered by examining an ordinary differential equation with a source term. For example, consider the initial value problem

$$y'(t) + ay = F(t), \quad t > 0; \quad y(0) = 0. \quad (2.32)$$

Multiplying by the integrating factor e^{at} makes the left side a total derivative, and we obtain

$$\frac{d}{dt}(e^{at}y) = e^{at}F(t).$$

Integrating from 0 to t then gives

$$e^{at}y(t) = \int_0^t e^{a\tau}F(\tau)d\tau,$$

which can be rewritten as

$$y(t) = \int_0^t e^{-a(t-\tau)}F(\tau)d\tau. \quad (2.33)$$

Now let us consider another problem, where we put the source term in as the initial condition. Let $w = w(t; \tau)$ be the solution to the problem

$$w'(t; \tau) + aw(t; \tau) = 0, \quad t > 0; \quad w(0; \tau) = F(\tau),$$

where a new parameter τ has been introduced. It is straightforward to see that the solution to this problem is

$$w(t; \tau) = F(\tau)e^{-at}.$$

So the solution to (2.32), the problem with a source, is the integral of the solution $w(t, \tau)$ (with t replaced by $t - \tau$) of the associated homogeneous problem where the source is included as an initial condition. That is,

$$y(t) = \int_0^t w(t - \tau; \tau)F(\tau) \tau = \int_0^t F(\tau)e^{-a(t-\tau)} d\tau,$$

which is (2.33).

The fact that a particular solution of a linear equation can be deduced from the solution of the homogeneous equation is called Duhamel's principle. For ODEs we state the principle as follows:

Theorem 2.4

(Duhamel's principle) The solution of the problem

$$y'(t) + ay = F(t), \quad t > 0; \quad y(0) = 0$$

is given by

$$y(t) = \int_0^t w(t - \tau, \tau)d\tau,$$

where $w = w(t, \tau)$ solves the homogeneous problem

$$w'(t; \tau) + aw(t; \tau) = 0, \quad t > 0; \quad w(0; \tau) = F(\tau). \quad \square$$

The same type of result is true for second-order ODEs as well; the reader may recall that the variation of parameters method uses the homogeneous solutions to construct a particular solution. See the Appendix for the formula.

Now let us extrapolate this idea and apply it to the heat flow problem (2.30)–(2.31). If Duhamel's principle is valid in this case, then the solution of (2.30)–(2.31) should be

$$u(x, t) = \int_0^t w(x, t - \tau, \tau) d\tau,$$

where $w(x, t; \tau)$ solves the homogeneous problem

$$w_t = kw_{xx}, \quad x \in \mathbb{R}, t > 0, \quad (2.34)$$

$$w(x, 0; \tau) = f(x, \tau), \quad x \in \mathbb{R}. \quad (2.35)$$

In fact, we can write down the explicit formula; by (2.8) the solution to (2.34)–(2.35) is

$$w(x, t; \tau) = \int_{-\infty}^{\infty} G(x - y, t) f(y, \tau) dy,$$

where G is the heat kernel. Therefore, the solution to (2.30)–(2.31) should be given by

$$u(x, t) = \int_0^t \int_{-\infty}^{\infty} G(x - y, t - \tau) f(y, \tau) dy d\tau.$$

Indeed, one can verify that this is the case.

It is not surprising that the solution turned out to be an integral. The PDE (2.30) has the form $Hu = f$, where $H = \frac{\partial}{\partial t} - k\frac{\partial^2}{\partial x^2}$ is a differential operator. If we formally write $u = H^{-1}f$ (as we might do in matrix theory if H were a matrix and u and f vectors), then we would expect H^{-1} , the inverse of H , to be an integral operator, since integration and differentiation are inverse processes.

We may now write down the formula for the solution to the problem

$$u_t = ku_{xx} + f(x, t), \quad x \in \mathbb{R}, t > 0, \quad (2.36)$$

$$u(x, 0) = \phi(x), \quad x \in \mathbb{R}, \quad (2.37)$$

where the initial condition is no longer zero. By linearity, the solution to (2.36)–(2.37) is the sum of the solutions to the two problems

$$u_t = ku_{xx}, \quad x \in \mathbb{R}, t > 0,$$

$$u(x, 0) = \phi(x), \quad x \in \mathbb{R},$$

and

$$u_t = ku_{xx} + f(x, t), \quad x \in \mathbb{R}, t > 0,$$

$$u(x, 0) = 0, \quad x \in \mathbb{R}.$$

Thus, the solution to (2.36)–(2.37) is

$$u(x, t) = \int_{-\infty}^{\infty} G(x - y, t) \phi(y) dy + \int_0^t \int_{-\infty}^{\infty} G(x - y, t - \tau) f(y, \tau) dy d\tau. \quad (2.38)$$

This is the **variation of parameters formula** for the problem (2.36)–(2.37).

Example 2.5

(**Wave equation**) Duhamel's principle can also be applied to the wave equation. The solution to the problem

$$u_{tt} - c^2 u_{xx} = f(x, t), \quad x \in \mathbb{R}, t > 0, \quad (2.39)$$

$$u(x, 0) = u_t(x, 0) = 0, \quad x \in \mathbb{R}, \quad (2.40)$$

is

$$u(x, t) = \int_0^t w(x, t - \tau, \tau) d\tau,$$

where $w = w(x, t; \tau)$ is the solution to

$$w_{tt} - c^2 w_{xx} = 0, \quad x \in \mathbb{R}, t > 0,$$

$$w(x, 0; \tau) = 0, \quad w_t(x, 0; \tau) = f(x, \tau), \quad x \in \mathbb{R}.$$

We put the source term f into the initial condition for w_t rather than for w because f , like w_t , is an acceleration; note that the displacement u is a time integral of w , so w must be a velocity, making w_t an acceleration. From d'Alembert's formula,

$$w(x, t; \tau) = \frac{1}{2c} \int_{x-ct}^{x+ct} f(s, \tau) ds,$$

and therefore by Duhamel's principle the solution to (2.39)–(2.40) is given by the formula

$$u(x, t) = \frac{1}{2c} \int_0^t \int_{x-c(t-\tau)}^{x+c(t-\tau)} f(s, \tau) ds d\tau. \quad \square \quad (2.41)$$

Source terms also arise in PDEs when problems are transformed in order to homogenize the boundary conditions.

Example 2.6

Consider the diffusion problem

$$u_t = k u_{xx}, \quad x > 0, t > 0, \quad (2.42)$$

$$u(x, 0) = \phi(x), \quad x > 0, \quad (2.43)$$

$$u(0, t) = g(t), \quad t > 0. \quad (2.44)$$

We solved this problem in the last section when $g(t) = 0$. So let us attempt to transform the problem into one where the boundary condition is zero. To this end, let $v(x, t) = u(x, t) - g(t)$, or $u(x, t) = v(x, t) + g(t)$; then substituting into (2.42)–(2.44) gives

$$v_t = kv_{xx} - g'(t), \quad x > 0, t > 0, \quad (2.45)$$

$$v(x, 0) = \psi(x) \equiv \phi(x) - g(0), \quad x > 0, \quad (2.46)$$

$$v(0, t) = 0, \quad t > 0. \quad (2.47)$$

Therefore, transformation of the dependent variable has changed the problem into one with a homogeneous boundary condition, but a price was paid—an inhomogeneity, or source term $-g'(t)$, was introduced into the PDE. In general, we can always homogenize the boundary conditions in a linear problem, but the result is an inhomogeneous PDE; so inhomogeneous boundary conditions can be traded for inhomogeneous PDEs. We can solve (2.45)–(2.47) for $v(x, t)$ by formulating a Duhamel's principle. In Section 2.6 we show that Laplace transform methods can also be applied to find the solution. \square

EXERCISES

1. Write a formula for the solution to the problem

$$\begin{aligned} u_{tt} - c^2 u_{xx} &= \sin x, \quad x \in \mathbb{R}, t > 0, \\ u(x, 0) &= u_t(x, 0) = 0, \quad x \in \mathbb{R}. \end{aligned}$$

Graph the solution surface when $c = 1$.

2. Write a formula for the solution to the problem

$$\begin{aligned} u_t - ku_{xx} &= \sin x, \quad x \in \mathbb{R}, t > 0, \\ u(x, 0) &= 0, \quad x \in \mathbb{R}. \end{aligned}$$

3. Using Duhamel's principle, find a formula for the solution to the initial value problem for the convection equation

$$u_t + cu_x = f(x, t), \quad x \in \mathbb{R}, t > 0; \quad u(x, 0) = 0, \quad x \in \mathbb{R}.$$

Hint: Look at the problem

$$w_t(x, t; \tau) + cw_x(x, t; \tau) = 0, \quad x \in \mathbb{R}, t > 0; \quad w(x, 0; \tau) = f(x, \tau), \quad x \in \mathbb{R}.$$

4. Solve the problem

$$u_t + 2u_x = xe^{-t}, \quad x \in \mathbb{R}, t > 0; \quad u(x, 0) = 0, \quad x \in \mathbb{R}.$$

5. Formulate Duhamel's principle and solve the initial boundary value problem

$$\begin{aligned} u_t &= ku_{xx} + f(x, t), \quad x > 0, t > 0, \\ u(x, 0) &= 0, \quad x > 0, \\ u(0, t) &= 0, \quad t > 0. \end{aligned}$$

Solution:

$$u(x, t) = \int_0^t \int_0^\infty (G(x-y, t-\tau) - G(x+y, t-\tau))f(y, \tau)dyd\tau.$$

2.6 Laplace Transforms

Laplace transforms are first encountered in elementary differential equations courses as a technique for solving linear, constant-coefficient, ordinary differential equations; Laplace transforms convert an ODE into an algebra problem. They are particularly useful for nonhomogeneous differential equations with impulse or discontinuous sources. The ideas easily extend to PDEs, where the operation of Laplace transformation converts PDEs to ODEs.

Let $u = u(t)$ be a piecewise continuous function on $t \geq 0$ that does not grow too fast; for example, assume that u is of *exponential order*, which means that $|u(t)| \leq c \exp(at)$ for t sufficiently large, where $a, c > 0$. Then the **Laplace transform** of u is defined by

$$(\mathcal{L}u)(s) \equiv U(s) = \int_0^\infty u(t)e^{-st}dt. \quad (2.48)$$

The Laplace transform is an example of an integral transform; it takes a given function $u(t)$ in the time domain and converts it to a new function $U(s)$, in the so-called transform domain. U and s are called the transform variables. The Laplace transform is linear in that

$$\mathcal{L}(c_1u + c_2v) = c_1\mathcal{L}u + c_2\mathcal{L}v$$

where c_1 and c_2 are constants. If the transform $U(s)$ is known, then $u(t)$ is called the inverse transform of $U(s)$ and we write $\mathcal{L}^{-1}U = u$. Pairs of Laplace

transforms and their inverses are tabulated in books of tables, and many software packages, such as MATLAB, have simple commands that yield transform pairs. A short table is given at the end of this section (Table 2.1).

The importance of the Laplace transform, like other transforms, is that it changes derivative operations to multiplication operations in the transform domain. In fact, we have

$$(\mathcal{L}u')(s) = sU(s) - u(0), \quad (2.49)$$

$$(\mathcal{L}u'')(s) = s^2U(s) - su(0) - u'(0). \quad (2.50)$$

Formulas (2.49) and (2.50) are readily derived using integration by parts, and they are the basic operational formulas for solving differential equations.

Example 2.7

Solve the initial value problem

$$u'' + u = 0, \quad t > 0; \quad u(0) = 0, \quad u'(0) = 1.$$

Taking Laplace transforms of both sides of the differential equation and using (2.50) gives

$$s^2U(s) - 1 + U(s) = 0,$$

or

$$U(s) = \frac{1}{1 + s^2}.$$

So, the ordinary differential equation has been transformed into an algebraic equation, and we solved the problem in the transform domain. To recover $u(t)$ from its transform $U(s)$ we look up the inverse transform in Table 2.1 to find

$$u(t) = \mathcal{L}^{-1} \left(\frac{1}{1 + s^2} \right) = \sin t,$$

which is the solution. \square

In the preceding example we were recovered a function from its Laplace transform by looking in a table. One may ask, in general, how to determine $u(t)$ from knowledge of its transform $U(s)$. The answer to this question requires knowledge of complex variables; it would take us far afield to give a thorough discussion. However, we do indicate the general formula to compute $u(t)$ from its transform $U(s)$. The **inversion formula** is

$$u(t) = (\mathcal{L}^{-1}U)(t) = \frac{1}{2\pi i} \int_{a-i\infty}^{a+i\infty} U(s)e^{st} ds.$$

The integral in this formula is a complex contour integral taken over the vertical straight line in the complex plane from $a - i\infty$ to $a + i\infty$. The number a is any real number for which the resulting path lies to the right of any singularities (poles, essential singular points, or branch points and cuts) of the function $U(s)$. A thorough discussion of the inversion formula can be found in the references .

Another important result that is extremely useful in calculations is the convolution theorem.

Theorem 2.8

(Convolution Theorem) Let u and v be piecewise continuous on $t \geq 0$ and of exponential order. Then

$$\mathcal{L}(u * v)(s) = U(s)V(s),$$

where

$$(u * v)(t) \equiv \int_0^t u(t - \tau)v(\tau)d\tau$$

is the **convolution** of u and v , and $U = \mathcal{L}u$, $V = \mathcal{L}v$. Therefore,

$$\mathcal{L}^{-1}(U(s)V(s)) = (u * v)(t). \quad \square$$

The convolution theorem tells what to take the transform of in order to get a product of Laplace transforms, namely, the convolution. It also states that the inverse transform of a product of two transforms is the convolution of the two. It is easy to verify that $(u * v)(t) = (v * u)(t)$, so the order of the convolution does not make a difference. We know that the Laplace transform is additive, but this shows it is not multiplicative. That is, the Laplace transform of a product is not the product of the Laplace transforms.

Example 2.9

Find the solution of the IVP

$$u' + 3u = f(t), \quad u(0) = 1.$$

Taking the transform of the equation gives

$$sU(s) - 1 + 3U(s) = F(s), \quad F(s) = \mathcal{L}f(t),$$

or

$$U(s) = \frac{1}{s+3} + \frac{1}{s+3}F(s).$$

Taking the inverse transform yields

$$u(t) = e^{-3t} + \mathcal{L}^{-1}\left(\frac{1}{s+3}F(s)\right).$$

The convolution theorem implies that the second term on the right is

$$e^{-3t} * f(t).$$

Therefore

$$u(t) = e^{-3t} + \int_0^t e^{-3(t-\tau)} f(\tau) d\tau. \quad \square$$

To review the preceding method, taking the Laplace transform of an ordinary differential equation for $u(t)$ results in an algebraic equation for $U(s)$ in the transform domain. We solve the algebraic equation for $U(s)$ and then recover $u(t)$ by inversion.

Partial Differential Equations

The same strategy applies to partial differential equations where the unknown is a function of two variables, for example $u = u(x, t)$. Now we transform on t , as before, with the variable x being a parameter unaffected by the transform. In particular, we define the **Laplace transform** of $u(x, t)$ by

$$(\mathcal{L}u)(x, s) \equiv U(x, s) = \int_0^\infty u(x, t)e^{-st} dt. \quad (2.51)$$

Then time derivatives transform as in (2.49) and (2.50); for example,

$$(\mathcal{L}u_t)(x, s) = sU(x, s) - u(x, 0), \quad (\mathcal{L}u_{tt})(x, s) = s^2U(x, s) - su(x, 0) - u_t(x, 0).$$

On the other hand, spatial derivatives are left unaffected; for example,

$$(\mathcal{L}u_x)(x, s) = \int_0^\infty \frac{\partial}{\partial x} u(x, t)e^{-st} dt = \frac{\partial}{\partial x} \int_0^\infty u(x, t)e^{-st} dt = U_x(x, s).$$

Therefore, upon taking Laplace transforms, a PDE in x and t is reduced to an ordinary differential equation in x ; all the t -derivatives are turned into multiplication in the transform domain. We point out that in some problems the transform may be taken on x , with t as a parameter. The choice depends on the type of boundary conditions.

Example 2.10

(Contaminant transport) Let $u = u(x, t)$ denote the concentration of a chemical contaminant dissolved in a fluid in the semi-infinite domain $x > 0$ at time t . Initially, assume that the domain is free from contamination. For

times $t > 0$ we impose a constant unit concentration of a contaminant on the boundary $x = 0$, and we ask how this contaminant diffuses into the region. Assuming a unit diffusion constant, the mathematical model is

$$\begin{aligned}u_t - u_{xx} &= 0, & x > 0, & t > 0, \\u(x, 0) &= 0, & x > 0, \\u(0, t) &= 1, & t > 0; & u(x, t) \text{ bounded.}\end{aligned}$$

Taking Laplace transforms of both sides of the PDE gives

$$sU(x, s) - U_{xx}(x, s) = 0.$$

This is an ordinary differential equation with x as the independent variable, and the solution is

$$U(x, s) = a(s)e^{-\sqrt{s}x} + b(s)e^{\sqrt{s}x}.$$

Because we want bounded solutions, we set $b(s) = 0$. Then

$$U(x, s) = a(s)e^{-\sqrt{s}x}.$$

Now we take the Laplace transform of the boundary condition to get $U(0, s) = 1/s$, where we have used $\mathcal{L}(1) = 1/s$. Therefore, $a(s) = 1/s$, and the solution in the transform domain is

$$U(x, s) = \frac{1}{s}e^{-\sqrt{s}x}.$$

Now we must invert the transform. Consulting Table 2.1 or a computer algebra program, we find that the solution is

$$u(x, t) = \operatorname{erfc}\left(\frac{x}{\sqrt{4t}}\right),$$

where erfc is the **complimentary error function** defined by the formula

$$\operatorname{erfc}(y) = 1 - \frac{2}{\sqrt{\pi}} \int_0^y e^{-r^2} dr.$$

Observe that

$$\operatorname{erfc}(y) = 1 - \operatorname{erf}(y).$$

The complimentary error function is plotted in Figure 2.8. \square

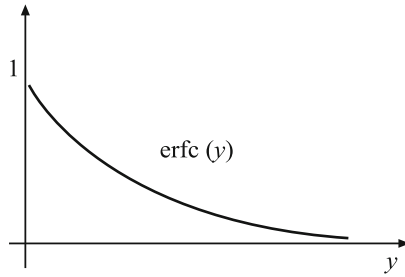

Figure 2.8 Plot of the complimentary error function $\text{erfc}(y)$. In the solution $y = x/\sqrt{4t}$

Example 2.11

In the contaminant transport model in the last example let us change the boundary condition to a function of time and consider

$$\begin{aligned} u_t - u_{xx} &= 0, \quad x > 0, \quad t > 0, \\ u(x, 0) &= 0, \quad x > 0, \\ u(0, t) &= f(t), \quad t > 0; \quad u(x, t) \text{ bounded.} \end{aligned}$$

Taking Laplace transforms of both sides of the PDE gives, as in the example,

$$sU(x, s) - U_{xx}(x, s) = 0,$$

which has solution

$$U(x, s) = a(s)e^{-\sqrt{s}x}.$$

Now we take a Laplace transform of the boundary condition to get $U(0, s) = F(s)$. Therefore, $a(s) = F(s)$ and the solution in the transform domain is

$$U(x, s) = F(s)e^{-\sqrt{s}x}.$$

Consulting Table 2.1, we find that

$$\mathcal{L}^{-1}\left(e^{-\sqrt{s}x}\right) = \frac{x}{\sqrt{4\pi t^3}}e^{-x^2/4t}.$$

Therefore, we can use the convolution theorem to write the solution as

$$u(x, t) = \int_0^t \frac{x}{\sqrt{4\pi(t-\tau)^3}}e^{-x^2/(4(t-\tau))}f(\tau)d\tau. \quad \square$$

A very complete reference for the Laplace transform, which includes an extensive table, theory, and applications, is Churchill (1970).

Parameter Identification Problems

In some physical problems all of the input parameters may not be known a priori. In a **parameter identification problem** we ask whether it is possible to take certain measurements and thereby determine an unknown parameter (a constant) or distributed parameter (a function) in a PDE. For example, suppose the diffusivity of a metal rod is unknown. Will holding the temperature constant at one end and measuring the heat flux out the other end determine the diffusivity? Parameter identification problems are a subclass of **inverse problems**; these can be described qualitatively as problems where the input is to be recovered from the output, rather than conversely, which is the case for so-called *direct problems*. All of the problems we encountered so far are direct problems (given all the data, find the solution), but one can argue that inverse problems play an equally important role in applied science. In many empirical problems we want to measure the output of experiments and use that information to determine properties of the system. In tomography, for example, we can learn about density variations in tissue by observing the reflection and transmission properties of sound waves. Here we will not be too ambitious, but rather only introduce some of the issues.

Example 2.12

Consider a long ($x \geq 0$) metal slab of unknown thermal conductivity K but known density ρ and specific heat c . For simplicity, take $\rho = c = 1$. Suppose further that measurements can be made only at the face $x = 0$. If a known temperature $f(t)$ at $x = 0$ is applied, can we measure the heat flux at $x = 0$ at a single instant of time t_0 and thereby determine K ? We assume $f(0) = 0$. The PDE model is

$$u_t = K u_{xx}, \quad x, t > 0, \quad (2.52)$$

$$u(0, t) = f(t), \quad t > 0, \quad (2.53)$$

$$u(x, 0) = 0, \quad x > 0, \quad (2.54)$$

which is a well-posed problem. We are asking whether we can determine K from a single flux measurement

$$-K u_x(0, t_0) = a, \quad (2.55)$$

where a is known. Using Laplace transforms we have already solved the direct problem. The solution is

$$u(x, t) = \int_0^t \frac{x}{\sqrt{4K\pi(t-\tau)^3}} e^{-x^2/(4K(t-\tau))} f(\tau) d\tau. \quad (2.56)$$

It appears that the strategy should be to calculate the flux at $(0, t_0)$ from the solution formula (2.56). Indeed this is the case, but calculating the x derivative of u is not a simple matter. The straightforward approach of pulling a partial derivative $\partial/\partial x$ under the integral sign fails because one of the resulting improper integrals cannot be evaluated at $x = 0$; it does not exist. The reader should verify this statement. Therefore, we must be more clever in calculating u_x . To this end we note that (2.56) can be written as

$$u(x, t) = -2K \int_0^t \frac{\partial}{\partial x} G(x, t - \tau) f(\tau) d\tau,$$

where $G(x, t)$ is the heat kernel

$$G(x, t) = \frac{1}{\sqrt{4\pi Kt}} e^{-x^2/(4Kt)}.$$

Therefore,

$$u_x(x, t) = -2K \int_0^t \frac{\partial^2}{\partial x^2} G(x, t - \tau) f(\tau) d\tau \quad (2.57)$$

$$= 2 \int_0^t \frac{\partial}{\partial \tau} G(x, t - \tau) f(\tau) d\tau, \quad (2.58)$$

since $-G_\tau = G_t = KG_{xx}$ (the heat kernel satisfies the heat equation). Now we integrate by parts to obtain

$$u_x(x, t) = -2 \int_0^t G(x, t - \tau) f'(\tau) d\tau.$$

The boundary terms generated by the integration by parts are zero. Consequently, we have

$$-Ku_x(0, t_0) = \sqrt{K} \int_0^{t_0} \frac{f'(\tau)}{\sqrt{\pi(t_0 - \tau)}} d\tau = a.$$

This equation uniquely determines K and solves the parameter identification problem.

For example, if $f(t) = \beta t$, i.e., the temperature is increased linearly, then the integral can be calculated exactly to obtain

$$K = \frac{\pi a^2}{4\beta^2 t_0}. \quad \square \quad (2.59)$$

Sections throughout the text provide exercises showing additional examples—typically, inverse problems, and in particular distributed parameter identification problems, lead to an integral equation for the unknown function. These equations are difficult to resolve, and stability is often a problem. That is, a small change in measurement can cause a large change in the calculated parameter value.

Table 2.1 Laplace Transforms

| $u(t)$ | $U(s)$ |
|--|--|
| 1 | $s^{-1}, \quad s > 0$ |
| e^{at} | $\frac{1}{s-a}, \quad s > a$ |
| t^n, n a positive integer | $\frac{n!}{s^{n+1}}, \quad s > 0$ |
| $\sin at$ and $\cos at$ | $\frac{a}{s^2+a^2}$ and $\frac{s}{s^2+a^2}, \quad s > 0$ |
| $\sinh at$ and $\cosh at$ | $\frac{a}{s^2-a^2}$ and $\frac{s}{s^2-a^2}, \quad s > a $ |
| $H(t-a)$ | $s^{-1}e^{-as}, \quad s > 0$ |
| $\delta(t-a)$ | e^{-as} |
| $H(t-a)f(t-a)$ | $F(s)e^{-as}$ |
| $f(t)e^{-at}$ | $F(s+a)$ |
| $H(t-a)f(t)$ | $e^{-as}\mathcal{L}(f(t+a))$ |
| $\operatorname{erf}\sqrt{t}$ | $s^{-1}(1+s)^{-1/2}, \quad s > 0$ |
| $\frac{1}{\sqrt{t}} \exp\left(\frac{-a^2}{4t}\right)$ | $\sqrt{\pi/s} e^{-a\sqrt{s}}, \quad (s > 0)$ |
| $1 - \operatorname{erf}\left(\frac{a}{2\sqrt{t}}\right)$ | $s^{-1}e^{-a\sqrt{s}}, \quad s > 0$ |
| $\frac{a}{2t^{3/2}} \exp\left(\frac{-a^2}{4t}\right)$ | $\sqrt{\pi} e^{-a\sqrt{s}}, \quad s > 0$ |

EXERCISES

1. Consider the nonhomogeneous initial value problem

$$u'' + 4u = te^{-t}, \quad u(0) = 0, \quad u'(0) = 0.$$

- a) Use Duhamel's principle to solve this problem. That is, show

$$u(t) = \int_0^t w(t-\tau, \tau) d\tau$$

where (w, τ) is the solution to

$$w'' + 4w = 0, \quad w(0, \tau) = 0, \quad w'(0, \tau) = \tau e^{-\tau}.$$

b) Use Laplace transforms to verify your solution.

2. Find the inverse transform of

$$U(s) = \frac{1}{s(s^2 + 1)}$$

using the convolution theorem.

3. Using the integral definition of Laplace transform, find the transform of $u(t) = \sqrt{t}$. Hint: Make the substitution $r^2 = st$.
4. Show that $\mathcal{L}\left(\int_0^t f(\tau) d\tau\right) = \frac{F(s)}{s}$.
5. Show that $\mathcal{L}(H(t-a)f(t-a)) = e^{-as}F(s)$, where H is the unit step function (the Heaviside function) defined by $H(x) = 0$ for $x < 0$, and $H(x) = 1$ for $x \geq 0$.
6. Solve $u_{tt} = u_{xx}$ for $x, t > 0$ with $u(0, t) = \sin t$, $t > 0$, and $u(x, 0) = 0$, $u_t(x, 0) = 1$, $x > 0$.
7. Solve $u_t = u_{xx}$ on $x, t > 0$ with $u(0, t) = a$, $t > 0$ and $u(x, 0) = b$, where a and b are constants.
8. Use Laplace transforms to solve the initial boundary value problem

$$\begin{aligned} u_t &= u_{xx}, \quad x > 0, \quad t > 0, \\ u_x(0, t) - u(0, t) &= 0, \quad t > 0, \\ u(x, 0) &= u_0, \quad x > 0. \end{aligned}$$

Interpret this model physically in the context of heat flow.

9. Find a bounded solution to

$$\begin{aligned} u_{tt} &= c^2 u_{xx} - f(t), \quad x > 0, \quad t > 0, \\ u(0, t) &= 0, \quad t > 0, \\ u(x, 0) &= u_t(x, 0) = 0, \quad x > 0. \end{aligned}$$

10. Solve the following problem using Laplace transforms.

$$\begin{aligned} u_{tt} &= c^2 u_{xx} - g, \quad x > 0, \quad t > 0, \\ u(0, t) &= 0, \quad t > 0, \\ u(x, 0) &= u_t(x, 0) = 0, \quad x > 0. \end{aligned}$$

The solution shows what happens to a falling cable lying on a table that is suddenly removed. Sketch some time snapshots of the solution.

11. In the quarter plane $x, y > 0$, where the temperature is initially zero, heat flows only in the y -direction; along the edge $y = 0$ heat is convected along the x -axis, and the temperature is constantly 1 at the point $x = y = 0$. The boundary value problem for the temperature $u(x, y, t)$ is

$$\begin{aligned}u_t &= u_{yy}, \quad x, t, y > 0, \\u(x, y, 0) &= 0, \quad x, y > 0, \\u(0, 0, t) &= 1, \quad t > 0, \\u_t(x, 0, t) + u_x(x, 0, t) &= 0, \quad x, t > 0.\end{aligned}$$

Find a bounded solution using Laplace transforms.

12. A very deep container of liquid is insulated on its sides. Initially, its temperature is a constant u_0 degrees, and for $t > 0$ heat radiates from its exposed top surface according to Newton's law of cooling (see Section 1.3). The air temperature is zero degrees. (a) Formulate an initial boundary value problem for the temperature of the liquid, and find a formula for the temperature at various depths at various times. (b) Take $\rho = c = K = \beta = 1$, and use a computer algebra system to plot some temperature profiles.
13. Derive the solution $u(x, t) = H(t - x/c)g(t - x/c)$ to the problem

$$\begin{aligned}u_{tt} &= c^2 u_{xx}, \quad x, t > 0, \\u(x, 0) = u_t(x, 0) &= 0, \quad x > 0, \\u(0, t) &= g(t), \quad t > 0.\end{aligned}$$

14. (Parameter identification) Suppose a chemical reactor occupying the space $x < 0$ operates at some unknown temperature $F(t)$. To determine $F(t)$ we insert a long, laterally insulated metal probe of unit diffusivity, and we measure the temperature $U(t)$ of the probe at $x = 1$. Assume that the probe occupies $0 \leq x < \infty$. Formulate the model equations and show that $F(t)$ satisfies the integral equation

$$U(t) = \frac{1}{2\sqrt{\pi}} \int_0^t \frac{F(\tau)}{(t-\tau)^{3/2}} e^{-1/4(t-\tau)} d\tau.$$

Hint: Solve the direct problem by Laplace transforms and use the table entry

$$\mathcal{L}^{-1}(e^{-\sqrt{s}x}) = \frac{x}{2\sqrt{\pi}t^{3/2}} e^{-x^2/(4t)}.$$

Suppose the temperature of the reactor $F(t)$ is a constant F_0 ; find F_0 if the temperature at $x = 1$ is found to be 10 degrees at $t = 5$.

15. Verify (2.59).

2.7 Fourier Transforms

The Fourier transform is another integral operator with properties similar to the Laplace transform in that derivatives are turned into multiplication operations in the transform domain. Thus the Fourier transform, like the Laplace transform, is useful as a computational tool in solving differential equations. In PDEs the Laplace transform is usually applied to the time variable, while the Fourier transform is often applied to the spatial variable when it varies over $(-\infty, \infty)$.

We begin with functions of one variable. The **Fourier transform** of a function $u = u(x)$, $x \in \mathbb{R}$, is defined by the equation

$$(\mathcal{F}u)(\xi) \equiv \hat{u}(\xi) = \int_{-\infty}^{\infty} u(x)e^{i\xi x} dx. \quad (2.60)$$

If u is absolutely integrable, i.e., $\int_{-\infty}^{\infty} |u| dx < \infty$, then $\hat{u} = \hat{u}(\xi)$ can be shown to exist.

The transform of a function $u = u(x)$ may, or may not, turn out to be a complex-valued function. The variable ξ is real, but the value $\hat{u}(\xi)$ can be complex. Further, there are a lot of common, simple functions that do not have a classical Fourier transform because the improper integral does not exist. For example,

$$u(x) = e^x \quad \text{and} \quad u(x) = C$$

do not have Fourier transforms. Only functions that decay at $\pm\infty$ sufficiently fast have Fourier transforms.

In the theory of Fourier transforms, it is common to work with the set \mathcal{S} of **rapidly decreasing functions** on \mathbb{R} : these are the functions with continuous derivatives of all orders, and for which each function and all its derivatives decay to zero as $x \rightarrow \pm\infty$ *faster than any power function* (functions like $1/x^2$ and $1/x^6$). The function $\exp(-x^2)$ defining the bell-shaped curve is a such a rapidly decreasing function. More technically, if the set of functions that have continuous derivatives of all orders on \mathbb{R} is denoted by C^∞ , then

$$\mathcal{S} = \{u \in C^\infty : |u^{(k)}(x)| \leq M|x|^{-N} \text{ as } |x| \rightarrow \infty, \\ k = 0, 1, 2, \dots; \text{ for all integers } N\}.$$

The set \mathcal{S} is called the **Schwartz class** of functions, and one can show that if $u \in \mathcal{S}$, then $\hat{u} \in \mathcal{S}$, and conversely. So \mathcal{S} is a closed set under both Fourier transformation and inversion, which makes it a good set to work with. In this text, however, a purely formal approach is not taken; rather, the goal is to understand how Fourier transforms provide a useful tool for problem-solving.

There is one important remark about notation. There is no standard convention on how to define the Fourier transform (2.60); some put a factor of $1/(2\pi)$ or $1/\sqrt{2\pi}$ in front of the integral, and some have a negative power in the exponential, or even include a factor of 2π in the exponential. One should be aware of these variations when consulting other sources, especially tables of transforms.

A basic property of the Fourier transform is that the k th derivative $u^{(k)}$ ($k = 1, 2, \dots$) transforms to an algebraic expression. That is,

$$(\mathcal{F}u^{(k)})(\xi) = (-i\xi)^k \hat{u}(\xi), \quad u \in \mathcal{S}, \quad (2.61)$$

confirming our comment that derivatives are transformed to multiplication (by a factor of $(-i\xi)^k$). This formula is easily proved using integration by parts (as for the Laplace transform); all the boundary terms generated in the integration by parts are zero, since u and all its spatial derivatives vanish at $\pm\infty$.

For functions of two variables, say $u = u(x, t)$, the variable t acts as a parameter, and we define on the variable x as

$$(\mathcal{F}u)(\xi, t) \equiv \hat{u}(\xi, t) = \int_{-\infty}^{\infty} u(x, t) e^{i\xi x} dx.$$

Then, under Fourier transformation, x -derivatives turn into multiplication, and t derivatives remain unaffected; for example,

$$\begin{aligned} (\mathcal{F}u_x)(\xi, t) &= (-i\xi)\hat{u}(\xi, t), \\ (\mathcal{F}u_{xx})(\xi, t) &= (-i\xi)^2\hat{u}(\xi, t), \\ (\mathcal{F}u_t)(\xi, t) &= \hat{u}_t(\xi, t). \end{aligned}$$

Solving a differential equation for u involves first transforming the problem into the transform domain (\hat{u} and ξ) and then solving the resulting differential equation for \hat{u} . One is then faced with the inversion problem, or the problem of determining the u for which $\mathcal{F}u = \hat{u}$. Another nice property of the Fourier transform is the simple form of the **inversion formula**, or inverse transform. It is

$$(\mathcal{F}^{-1}\hat{u})(x) \equiv u(x) = \frac{1}{2\pi} \int_{-\infty}^{\infty} \hat{u}(\xi) e^{-i\xi x} d\xi. \quad (2.62)$$

This result is called the **Fourier integral theorem**; it dictates how to get back from the transform domain.

Some Fourier transforms can be calculated directly, but many require complex contour integration. In the next example we calculate the transform using a differential equation technique.

Example 2.13

We calculate the transform of the Gaussian function $u(x) = e^{-ax^2}$, $a > 0$, or the classical bell-shaped curve. By definition,

$$\hat{u}(\xi) = \int_{-\infty}^{\infty} e^{-ax^2} e^{i\xi x} dx.$$

Differentiating with respect to ξ and then integrating by parts gives

$$\begin{aligned} \hat{u}'(\xi) &= i \int_{-\infty}^{\infty} x e^{-ax^2} e^{i\xi x} dx \\ &= \frac{-i}{2a} \int_{-\infty}^{\infty} \frac{d}{dx} e^{-ax^2} e^{i\xi x} dx \\ &= \frac{-\xi}{2a} \hat{u}(\xi). \end{aligned}$$

Therefore, we have a differential equation $\hat{u}' = \frac{-\xi}{2a} \hat{u}$ for \hat{u} . Separating variables and integrating gives the general solution

$$\hat{u}(\xi) = C e^{-\xi^2/(4a)}.$$

The constant C can be determined by noticing that

$$\hat{u}(0) = \int_{-\infty}^{\infty} e^{-ax^2} dx = \sqrt{\frac{\pi}{a}}.$$

Consequently, we have

$$\mathcal{F}(e^{-ax^2}) = \sqrt{\frac{\pi}{a}} e^{-\xi^2/(4a)}. \quad (2.63)$$

So, the Fourier transform of a Gaussian function is itself a Gaussian; likewise, the inverse transform of a Gaussian is a Gaussian. Equation (2.63) has an important interpretation. Let us regard $u(x) = e^{-ax^2}$, $a > 0$ as a signal representing information. If a is large, then the signal, i.e., the bell-shaped curve, has a very high, narrow peak; information in the signal is localized and coherent. In the transform domain, however, the signal $\hat{u}(\xi)$ is broad with a low peak. The information has spread and coherence is lost. The opposite is true when a is small: broad signals transform to narrow ones. \square

Remark. We can think of a Fourier transform as resolving a function into all of its frequencies. A measurement of the **frequency spectrum** is the modulus $|\hat{u}(\xi)|$. \square

Example 2.14

If $u(x) = H(x + 1) - H(x - 1)$ (a square pulse), then it is easily shown that $\hat{u}(\xi) = \frac{2 \sin \xi}{\xi}$. The frequency spectrum is

$$|\hat{u}(\xi)| = \frac{2 \sin |\xi|}{|\xi|}.$$

The plot of the frequency spectrum shows the frequency composition of the square wave pulse. \square

Similar to the case of Laplace transforms, a convolution relation holds for Fourier transforms. If $u, v \in \mathcal{S}$, then we define their **convolution**, which is in \mathcal{S} , by

$$(u * v)(x) = \int_{-\infty}^{\infty} u(x - y)v(y)dy.$$

Then we have the following theorem.

Theorem 2.15

(Convolution theorem) If $u, v \in \mathcal{S}$, then

$$\mathcal{F}(u * v)(\xi) = \hat{u}(\xi)\hat{v}(\xi). \quad \square$$

By the Fourier integral theorem it follows immediately that

$$(u * v)(x) = \mathcal{F}^{-1}(\hat{u}(\xi)\hat{v}(\xi)).$$

This formula states that the inverse transform of a product of Fourier transforms is a convolution; this is a useful relationship in solving differential equations.

Example 2.16

Let $f \in \mathcal{S}$ and determine u for which

$$u'' - u = f(x), \quad x \in \mathbb{R}.$$

Taking the transform of both sides yields

$$(-i\xi)^2 \hat{u} - \hat{u} = \hat{f},$$

or

$$\hat{u}(\xi) = -\frac{1}{1 + \xi^2} \hat{f}(\xi).$$

In the transform domain the solution is a product of transforms, and so we apply the convolution theorem. From the Exercises we have

$$\mathcal{F}\left(\frac{1}{2}e^{-|x|}\right) = \frac{1}{1+\xi^2}.$$

Therefore,

$$u(x) = -\frac{1}{2}e^{-|x|} * f(x) = -\frac{1}{2} \int_{-\infty}^{\infty} e^{-|x-y|} f(y) dy. \quad \square$$

The strategy in applying transform methods to solve partial differential equations is to proceed formally, making any assumptions that are required to obtain an answer; for example, assume that all the data is in \mathcal{S} . When a solution is obtained one can then attempt to verify that it is indeed a solution to the problem. Often one can prove that the solution obtained holds under less severe conditions than required in the application of the transform method.

Now we apply the Fourier transform method to the Cauchy problem for the heat equation. We will derive the same solution formula (2.8) that we obtained in Section 2.1 by a different method.

Example 2.17

(Heat equation) Use Fourier transforms to solve the pure initial value problem for the heat equation:

$$u_t - ku_{xx} = 0, \quad x \in \mathbb{R}, t > 0; \quad u(x, 0) = f(x), \quad x \in \mathbb{R}. \quad (2.64)$$

Again we assume that $f \in \mathcal{S}$. Taking Fourier transforms of the PDE gives

$$\hat{u}_t = -\xi^2 k \hat{u},$$

which is an ordinary differential equation in t for $\hat{u}(\xi, t)$, with ξ as a parameter. Its solution is

$$\hat{u}(\xi, t) = C e^{-\xi^2 kt}.$$

But the initial condition gives $\hat{u}(\xi, 0) = \hat{f}(\xi)$, and so $C = \hat{f}(\xi)$. Therefore,

$$\hat{u}(\xi, t) = e^{-\xi^2 kt} \hat{f}(\xi).$$

Replacing a by $1/(4kt)$ in formula (2.63) gives

$$\mathcal{F}\left(\frac{1}{\sqrt{4\pi kt}} e^{-x^2/(4kt)}\right) = e^{-\xi^2 kt}.$$

Thus, by the convolution theorem we have

$$u(x, t) = \int_{-\infty}^{\infty} \frac{1}{\sqrt{4\pi kt}} e^{-(x-y)^2/(4kt)} f(y) dy. \quad (2.65)$$

This solution was derived under the assumption that f is in the Schwartz class. But now that we have it, we can attempt to show that it is a solution under milder restrictions on f . For example, one can prove that (2.65) is a solution to (2.64) if f is a continuous, bounded function on \mathbb{R} . \square

Example 2.18

(Laplace's equation in a half plane) Now we solve a basic problem involving Laplace's equation in the upper half plane. Consider

$$u_{xx} + u_{yy} = 0, \quad x \in \mathbb{R}, y > 0; \quad u(x, 0) = f(x), \quad x \in \mathbb{R}.$$

We also append the condition that the solution u remains bounded as $y \rightarrow \infty$. This example is similar to the last example. Taking the transform (on x with y as a parameter) of the PDE, we obtain

$$\hat{u}_{yy} - \xi^2 \hat{u} = 0,$$

which has general solution

$$\hat{u}(\xi, y) = a(\xi)e^{-\xi y} + b(\xi)e^{\xi y}.$$

The boundedness condition on u forces $b(\xi) = 0$ if $\xi > 0$ and $a(\xi) = 0$ if $\xi < 0$. So we take

$$\hat{u}(\xi, y) = c(\xi)e^{-|\xi|y}.$$

Upon applying Fourier transforms to the boundary condition, we get $c(\xi) = \hat{f}(\xi)$. Therefore, the solution in the transform domain is

$$\hat{u}(\xi, y) = e^{-|\xi|y} \hat{f}(\xi).$$

Then, using the convolution theorem, we obtain the solution

$$u(x, y) = \frac{y}{\pi} \frac{1}{x^2 + y^2} * f = \frac{y}{\pi} \int_{-\infty}^{\infty} \frac{f(\tau) d\tau}{(x - \tau)^2 + y^2}. \quad \square$$

An excellent, brief introduction to Fourier transforms can be found in Vretblad (2006).

EXERCISES

1. Find the convolution of the functions $f(x) = x$ and $g(x) = e^{-x^2}$.
2. Show that the inverse Fourier transform of $e^{-a|\xi|}$, $a > 0$, is

$$\frac{a}{\pi} \frac{1}{x^2 + a^2}.$$

3. Verify the following properties of the Fourier transform:

a) $(\mathcal{F}u)(\xi) = 2\pi(\mathcal{F}^{-1}u)(-\xi)$.

b) $\mathcal{F}(e^{iax}u)(\xi) = \hat{u}(\xi + a)$.

c) $\mathcal{F}(u(x + a)) = e^{-ia\xi}\hat{u}(\xi)$.

Formula (a) states that if a transform is known, so is its inverse, and conversely.

4. If $\mathcal{F}(xe^{-|x|}) = \frac{4i\xi}{(1+\xi^2)^2}$, find $\mathcal{F}\left(\frac{x}{(1+x^2)^2}\right)$.

5. If $u(x) = e^{-|x|}$, compute $u * u$ and then find the inverse Fourier transform of $\frac{1}{(1+\xi^2)^2}$.

6. Find the Fourier transform of the function u defined by $u(x) = e^{-ax}$ if $x > 0$, and $u(x) = 0$ if $x \leq 0$. Plot the frequency spectrum.

7. Compute $\mathcal{F}(xe^{-ax^2})$. Hint: Use (2.61).

8. Compute the Fourier transform of $u(x) = \cos ax$ if $|x| < \pi/2a$, and $u(x) = 0$ if $|x| > \pi/2a$.

9. Solve the following initial value problem for the inhomogeneous heat equation:

$$u_t = u_{xx} + F(x, t), \quad x \in \mathbb{R}, t > 0 \quad u(x, 0) = 0, \quad x \in \mathbb{R}.$$

10. Find a formula for the solution to the following initial value problem for the free Schrödinger equation:

$$u_t = iu_{xx}, \quad x \in \mathbb{R}, t > 0; \quad u(x, 0) = e^{-x^2}, \quad x \in \mathbb{R}.$$

11. Find a bounded solution to the Neumann problem

$$\begin{aligned} u_{xx} + u_{yy} &= 0, \quad x \in \mathbb{R}, y > 0, \\ u_y(x, 0) &= g(x), \quad x \in \mathbb{R}. \end{aligned}$$

Hint: Let $v = u_y$ and reduce the problem to a Dirichlet problem. The solution is

$$u(x, y) = \frac{1}{2\pi} \int_{-\infty}^{\infty} g(x - \xi) \ln(y^2 + \xi^2) d\xi + C.$$

12. Solve the boundary value problem

$$\begin{aligned} u_{xx} + u_{yy} &= 0, \quad x \in \mathbb{R}, y > 0, \\ u(x, 0) &= 1, \quad |x| \leq l; \quad u(x, 0) = 0, \quad |x| > l. \end{aligned}$$

13. Use integration by parts to verify (assume $u \in \mathcal{S}$)

$$\begin{aligned}(\mathcal{F}u_x)(\xi, t) &= (-i\xi)\hat{u}(\xi, t), \\ (\mathcal{F}u_{xx})(\xi, t) &= (-i\xi)^2\hat{u}(\xi, t).\end{aligned}$$

14. Let $u(x)$ be a square wave, i.e. $u(x) = 1$ if $|x| \leq a$ and $u(x) = 0$ if $|x| > a$. Show that

$$(\mathcal{F}u)(\xi) = \frac{2 \sin a\xi}{\xi}.$$

Plot the frequency spectrum.

15. Solve the Cauchy problem for the advection–diffusion equation using Fourier transforms:

$$u_t = Du_{xx} - cu_x, \quad x \in \mathbb{R}, \quad t > 0; \quad u(x, 0) = \phi(x), \quad x \in \mathbb{R}.$$

16. This exercise explores the role of a term u_{xxx} (called a **dispersion** term) in a PDE by examining the equation

$$u_t + u_{xxx} = 0.$$

This equation is sometimes called the linearized Korteweg–deVries (KdV) equation.

- a) What relation between ω and k would have to hold if a solution of the form

$$u(x, t) = e^{i(kx - \omega t)}$$

exists? What do these solutions look like, and how does their speed depend on k ? What does your conclusion mean, qualitatively? (Recall that the real and imaginary parts of a complex solution to a linear equation are both real solutions.)

- b) Use Fourier transforms to solve the Cauchy problem for the linearized KdV equation, and write your answer in terms of the **Airy function** defined by

$$\text{Ai}(x) = \frac{1}{2\pi} \int_{-\infty}^{\infty} \cos\left(\frac{z^3}{3} + xz\right) dz.$$

17. Take a Gaussian function $\exp(-x^2)$ as the initial condition for the Cauchy problem for the heat equation and find the solution profile when $t = 1$.
18. Use Fourier transforms to derive d'Alembert's solution (2.14) to the Cauchy problem for the wave equations (2.12)–(2.13) when the initial velocity is zero, i.e., $g(x) \equiv 0$.

19. (Parameter identification) It is believed that nerve impulses are transmitted along axons by both diffusion and convection. In fundamental experiments the biologists Hodgkin and Keyes used radioactive potassium ^{42}K to measure how ions convect and diffuse in squid axons. If $u = u(x, t)$ is the concentration of potassium in a long axon, then the convection–diffusion model is

$$u_t = Du_{xx} - vu_x, \quad x \in \mathbb{R}, \quad t > 0.$$

The velocity v can be measured directly, but the diffusion constant D is difficult to measure. To determine D take a known initial concentration $u(x, 0) = e^{-x^2/a}$ and solve for the concentration $u(x, t)$. Obtain

$$u(x, t) = \frac{\sqrt{a}}{\sqrt{a + 4Dt}} e^{-(x-vt)^2/(a+4Dt)}.$$

Show how D can be recovered from a continuous measurement $U(t) = u(x_0, t)$ of the potassium concentration at some fixed location $x = x_0$.

20. Solve the integral equation for f :

$$\int_{-\infty}^{\infty} f(x-y)e^{-y^2} dy = e^{-x^2/4}.$$

3

Orthogonal Expansions

In this chapter we study topics that form the traditional core of applied mathematics—*boundary value problems* and *orthogonal expansions*. These subjects are interrelated in one of the most aesthetic theories in all of mathematics.

In an abstract sense, mathematics can be thought of as imposing structures on sets of objects and studying their properties. In linear algebra, for example, an algebraic structure (addition and scalar multiplication) is defined on a finite-dimensional vector space, typically \mathbb{R}^n , along with geometric structures that characterize concepts like distance and orthogonality (perpendicularity). Finally, linear transformations, represented by matrices, between vector spaces can be introduced and we can study how those interrelate with the algebraic and geometric structures. This all leads to the solution of linear systems, the algebraic eigenvalue problem, and the decomposition of the vector space and the transformation into fundamental, or canonical, forms. What is exciting is that all of these ideas extend in a straightforward way to infinite-dimensional *function spaces* and linear differential operators defined boundary value problems on those spaces. The theory is not only insightful and unifying, but it has far-reaching applications to science, engineering, and mathematics.

3.1 The Fourier Method

Without a lot of detail, we begin with an example that indicates how these ideas apply to initial boundary value problems in PDEs. The key question, as

we observe, is whether a function $f(x)$ can be expanded in a linear combinations of ‘basis’ functions, analogous to expanding a vector in terms of orthogonal basis vectors. Next we see why this question arises.

The basic technique for solving PDEs on a bounded spatial domain is the Fourier method, named after Joseph Fourier (1768–1830). In this first section we take a nineteenth-century perspective and make some comments about the origin of the method. Our discussion will motivate one of the most fundamental topics in analysis and in PDEs, namely orthogonal expansions.

To fix the notion let us consider heat flow in a finite bar of length $l = \pi$ and unit diffusivity ($k = 1$), where the ends are held at zero degrees. We choose π as the length to make the constants come out simpler at the end. From Chapter 1 we know that the temperature $u = u(x, t)$ in a laterally insulated bar must satisfy the model equations

$$u_t = u_{xx}, \quad 0 < x < \pi; \quad t > 0, \quad (3.1)$$

$$u(0, t) = u(\pi, t) = 0, \quad t > 0, \quad (3.2)$$

consisting of the heat equation and the boundary conditions. For the moment, we ignore the initial condition. It is easy to check that for any positive integer n , a solution to (3.1) is given by

$$u_n(x, t) = e^{-n^2 t} \sin nx. \quad (3.3)$$

Each of these solutions clearly satisfies the boundary conditions (3.2) as well. For the moment, put a hold on your curiosity about the origin of the set of solutions in (3.3).

As we know, for a well-posed problem, equations (3.1) and (3.2) are augmented by an initial condition of the form

$$u(x, 0) = f(x), \quad 0 < x < \pi. \quad (3.4)$$

We now ask how a solution to the *initial* BVP can be constructed from only the solutions (3.3) of the boundary value problem? Fourier argued that the solution $u(x, t)$ to (3.1), (3.2), (3.4) can be taken as a linear combination of the infinite number of solutions $u_n(x, t)$ in (3.3); that is,

$$u(x, t) = \sum_{n=1}^{\infty} a_n e^{-n^2 t} \sin nx \quad (3.5)$$

for appropriately chosen constants a_n . To satisfy the initial condition, (3.4) implies that

$$u(x, 0) = f(x) = \sum_{n=1}^{\infty} a_n \sin nx. \quad (3.6)$$

This means the initial temperature function $f(x)$ must be an infinite series representation in terms of the periodic ‘basis’ functions $\sin x, \sin 2x, \sin 3x, \dots$

On a historical note, the calculation was troublesome in Fourier’s time, in the early 1800s. Concepts like convergence of series were not well understood. L. Euler, D. Bernoulli, and d’Alembert, all of whom had addressed similar problems in the mid-1700s regarding the wave equation and vibrating strings, had wondered about the possibility of expanding a nonperiodic function $f(x)$ in terms of periodic functions like sines and cosines. It was L. Dirichlet who in 1829 finally established conditions under which such series representations like (3.6) are valid. In fact, these ideas about convergence of Fourier series gave tremendous impetus to the development of mathematical analysis in the 19th century.

To determine the coefficients a_n that make (3.6) valid, one could proceed formally and multiply both sides of (3.6) by $\sin mx$, for some fixed but arbitrary index m , and then integrate from $x = 0$ to $x = \pi$ to obtain

$$\int_0^\pi f(x) \sin mx \, dx = \int_0^\pi \sum_{n=1}^{\infty} a_n \sin nx \sin mx \, dx.$$

If we interchange the integral and the summation sign we obtain

$$\int_0^\pi f(x) \sin mx \, dx = \sum_{n=1}^{\infty} a_n \int_0^\pi \sin nx \sin mx \, dx.$$

The integrals in the right side summand can be calculated. We find that

$$\int_0^\pi \sin nx \sin mx \, dx = 0, \quad n \neq m. \quad (3.7)$$

Amazingly, this fact forces the infinite series to collapse to a single term. So the only term that survives in the infinite series is the one where the dummy summation index n hits m , the fixed index. Therefore we get

$$\int_0^\pi f(x) \sin mx \, dx = a_m \int_0^\pi \sin^2 mx \, dx = \frac{\pi}{2} a_m.$$

Because m is an arbitrary fixed index, we can replace it by n and so we have shown that the coefficients in (3.6) are given by

$$a_n = \frac{2}{\pi} \int_0^\pi f(x) \sin nx \, dx, \quad n = 1, 2, 3, \dots \quad (3.8)$$

Therefore, in summary, in a formal sense⁶ the solution to the heat flow problem (3.1)–(3.2)–(3.4) is given by (3.5), where the coefficients a_n are given

⁶ A formal calculation in mathematics is one done without complete rigor, but can be verified under special assumptions.

by (3.8). Indeed, one can verify that this is a solution for reasonable initial temperature distributions $f(x)$.

What we described is Fourier's method; namely, we solve a general initial boundary value problem by superimposing a set of solutions to the pure boundary value problem and then choosing the constants such that the initial condition is satisfied as well. The key to the calculation is that the functions $\sin nx$ satisfy a relation like (3.7), which is called an **orthogonality condition**. It is analogous to the expansion of a vector in \mathbb{R}^n in terms of orthogonal vectors, or a basis. Orthogonality enables easy calculation of coefficients in the infinite series (3.6). The infinite series (3.6) for $f(x)$ in terms of the orthogonal functions $\sin nx$ is called an **orthogonal expansion**. We have glossed over several key steps, but in the next section we state the definitions and concepts in much greater detail and show their validity.

Fourier's method is the basic technique for solving boundary value problems for PDEs on bounded domains. One obvious, remaining, question is how we obtained the set of solutions

$$u_n(x, t) = e^{-n^2 t} \sin nx, \quad n = 0, 1, 2, \dots$$

that forms a basis for the expansion. The answer is: from a differential *eigenvalue problem*. We fully discuss this eigenvalue problem in Chapter 4. But for the present, we focus attention on the representation of functions by infinite series like the orthogonal expansion (3.6).

EXERCISES

1. Consider the initial boundary value problem for the wave equation

$$u_{tt} = c^2 u_{xx}, \quad 0 < x < \pi, \quad t > 0, \quad (3.9)$$

$$u(0, t) = u(\pi, t) = 0, \quad t > 0, \quad (3.10)$$

$$u(x, 0) = f(x), \quad u_t(x, 0) = 0, \quad 0 < x < \pi, \quad (3.11)$$

on a bounded spatial domain. Recall that this system models the small, transverse deflections of a taut string fixed at the two endpoints.

- a) Verify that the set of functions,

$$u_n(x, t) = \cos nct \sin nx, \quad n = 1, 2, \dots,$$

satisfies the PDE (3.9) and boundary conditions (3.10).

- b) These solutions are called **fundamental modes** and they represent **standing waves**. Plot several time profiles of the fundamental mode corresponding to $n = 2$ and $c = 1$.

c) Superimpose the fundamental modes by defining

$$u(x, t) = \sum_n a_n \cos nct \sin nx$$

and determine the coefficients a_n for which $u(x, t)$ satisfies the initial conditions (3.11).

d) Show formally that $u(x, t)$ solves the initial BVP (3.9)–(3.11). (You may differentiate term-by-term.) These calculations amount to resolving an arbitrary wave into its fundamental modes.

e) Find a formal solution as above if the initial conditions are changed to

$$u(x, 0) = 0, \quad u_t(x, 0) = g(x), \quad 0 < x < \pi.$$

3.2 Orthogonal Expansions

From elementary calculus the reader is familiar with the notion of expanding a given function $f(x)$ in an infinite series of simpler functions. For example, if f has infinitely many derivatives at a point $x = a$, then its *Taylor series* about $x = a$ is

$$f(x) = \sum_{n=0}^{\infty} c_n (x - a)^n,$$

where the c_n , the Taylor coefficients, are given by

$$c_n = f^{(n)}(a)/n!.$$

For example, the Taylor series for the exponential function about $x = a = 0$ is

$$e^x = 1 + x + \frac{1}{2!}x^2 + \frac{1}{3!}x^3 + \dots.$$

Another type of series is a Fourier series. If f is defined and integrable on the interval $[-\pi, \pi]$, then its **Fourier series** is an infinite series of the form

$$\frac{a_0}{2} + \sum_{n=1}^{\infty} (a_n \cos nx + b_n \sin nx), \quad (3.12)$$

where the coefficients are calculated by the formulas

$$a_n = \frac{1}{\pi} \int_{-\pi}^{\pi} f(x) \cos nxdx, \quad n = 0, 1, 2, \dots,$$

$$b_n = \frac{1}{\pi} \int_{-\pi}^{\pi} f(x) \sin nxdx, \quad n = 1, 2, \dots$$

For Taylor series we use the set of polynomial functions $1, x - a, (x - a)^2, \dots$ as the basis for the expansion, and for Fourier series we use the trigonometric functions $1, \cos x, \cos 2x, \dots, \sin x, \sin 2x, \dots$ as the basis for the expansion. Each expansion has its advantages. From calculus we know that a few terms of the Taylor series can provide a good approximation to f locally near $x = a$. On the other hand, the first few terms of a Fourier series can provide a good global approximation to periodic signals.

Example 3.1

We illustrate how to calculate the Fourier series (3.12) of the step function

$$f(x) = 0, \quad -\pi \leq x < 0, \quad f(x) = 1, \quad 0 \leq x \leq \pi$$

on the interval $[-\pi, \pi]$. The coefficients, given above, are

$$a_0 = \frac{1}{\pi} \int_{-\pi}^{\pi} f(x) dx = \frac{1}{\pi} \int_0^{\pi} 1 dx = 1,$$

$$a_n = \frac{1}{\pi} \int_{-\pi}^{\pi} f(x) \cos nx dx = \frac{1}{\pi} \int_0^{\pi} \cos nx dx = \frac{1}{n\pi} \sin nx \Big|_0^{\pi} = 0,$$

and

$$b_n = \frac{1}{\pi} \int_{-\pi}^{\pi} f(x) \sin nx dx = \frac{1}{\pi} \int_0^{\pi} \sin nx dx = -\frac{1}{n\pi} \cos nx \Big|_0^{\pi},$$

$$= -\frac{1}{n\pi} (\cos n\pi - 1) = \frac{1}{n\pi} (1 - (-1)^{n+1}).$$

Here we used the fact that $\cos n\pi = (-1)^n$. Thus, the Fourier series (3.12) is

$$f(x) = \frac{1}{2} + \frac{2}{\pi} \left(\sin x + \frac{1}{3} \sin 3x + \frac{1}{5} \sin 5x + \frac{1}{7} \sin 7x + \dots \right).$$

A plot of the first five terms is shown in Figure 3.1. Note that the value of the Fourier series at the discontinuity $x = 0$ seems to be $1/2$, the midpoint value at the jump. \square

In this section we want to understand the underlying idea of a Fourier expansion by allowing the basis functions to be any set of functions with an *orthogonality* property. The result will be a general theory that incorporates Fourier series as a special case. Orthogonal is another word for perpendicular, but it has meaning in more general settings, such as with respect to sets of functions.

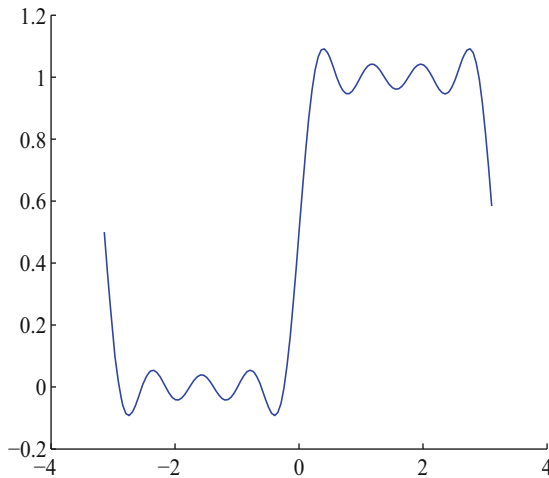

Figure 3.1 A five-term Fourier ‘wavy’ series approximation of the function $f(x) = 0$, $-\pi \leq x < 0$, $f(x) = 1$, $0 \leq x \leq \pi$. More terms give a better approximation in the open intervals $(-\pi, 0)$ and $(0, \pi)$

To fix the context, let us define a space of functions $L^2 \equiv L^2[a, b]$ consisting of all the real-valued functions f defined on the interval $[a, b]$ for which

$$\int_a^b |f(x)|^2 dx < \infty.$$

When this property holds, we say that f is **square integrable**⁷ and write $f \in L^2[a, b]$. In this set of functions we define an inner product (or scalar product), which is analogous to the dot product for vectors. If $f, g \in L^2$, then the **inner product** of f and g is a real number, denoted by (f, g) , and is defined by

$$(f, g) = \int_a^b f(x)g(x)dx.$$

By the properties of integrals, the inner product of functions satisfies the same properties of dot products for vectors, namely, *symmetry*, *additivity*, and

⁷ The integral here is, appropriately, the Lebesgue integral studied in advanced analysis courses rather than the Riemann integral, which is studied in elementary calculus; however, there will be no harm in interpreting the integrals in this text as a Riemann integrals since all of the functions that we examine are Riemann integrable (and therefore Lebesgue integrable).

homogeneity:

$$\begin{aligned}(f, g) &= (g, f), \\ (f, g + h) &= (f, g) + (f, h), \\ (f, \alpha g) &= \alpha(f, g), \quad \alpha \in \mathbb{R}.\end{aligned}$$

We also introduce the notion of length, or size, in the set $L^2[a, b]$. If $f \in L^2[a, b]$, then we define the **norm** of f to be the nonnegative real number

$$\|f\| \equiv \sqrt{(f, f)} = \sqrt{\int_a^b |f(x)|^2 dx}.$$

Observe that this definition is exactly analogous to the definition of the length of a vector \mathbf{v} in Euclidean space \mathbb{R}^n : $\|\mathbf{v}\| = \sqrt{\mathbf{v} \cdot \mathbf{v}}$. Introducing an inner product puts a geometric structure on L^2 that allows us to define lengths and perpendicularity, just as in \mathbb{R}^n .

The set L^2 is an example of a **function space** (a vector space of functions) analogous to \mathbb{R}^n , which is simply called a vector space. One can add functions in L^2 in the usual way and multiply functions in L^2 by scalars (real numbers). Those operations satisfy the same rules as addition of vectors in \mathbb{R}^n and multiplication of vectors by scalars. Thus L^2 and \mathbb{R}^n are similar in their algebraic structures and their geometric structures. However, a big difference is that \mathbb{R}^n is finite dimensional, whereas the function space L^2 is infinite dimensional. This means there is not a *finite* number of functions that form a basis for L^2 .

By the way, for notational convenience we often drop the explicit dependence of functions on x and write just f in place of $f(x)$. In some instances, when f represents a signal, we think of x as time.

Remark. It should be clear that other important spaces of functions on the closed interval $[a, b]$, e.g., continuous functions, piecewise continuous functions, differentiable functions, and so forth, are subsets of L^2 . So the set of functions L^2 contains all the functions we normally work with in engineering and science.

Example 3.2

Let $f(x) = x^3$ and $g(x) = 1 + x$ on the interval $[0, 1]$. These functions are clearly in L^2 . The inner product is

$$(f, g) = \int_0^1 x^3(1 + x)dx = \frac{9}{20}.$$

The norm f is measured by

$$\|f\| = \sqrt{\int_0^1 (x^3)^2 dx} = \sqrt{\frac{1}{7}}.$$

The norm is the square root of the area under the graph of the *square* of the given function. \square

We say that a set of functions f_1, f_2, f_3, \dots in $L^2[a, b]$ is **orthogonal** on the interval $[a, b]$ if $(f_i, f_j) = 0$ for $i \neq j$ and $(f_j, f_j) = \|f_j\|^2 \neq 0$.

Example 3.3

The set $1, \cos x, \cos 2x, \cos 3x, \dots, \sin x, \sin 2x, \sin 3x, \dots$ is orthogonal on $[-\pi, \pi]$ because if we integrate the product of any two of these over the interval $[-\pi, \pi]$ we get zero. The reader should verify this statement using formulas from a calculus book.

For another example, we observed in the last section that

$$(\sin mx, \sin nx) = \int_0^\pi \sin mx \sin nx \, dx = 0, \quad n \neq m.$$

Thus the set of functions $\sin x, \sin 2x, \dots$ is orthogonal on the interval $[0, \pi]$. The reader should check that the power functions $1, x, x^2, \dots$ that appear in a Taylor series do *not* form an orthogonal set on any interval $[a, b]$. \square

Finally, we remark that functions can be **normalized** in the same way that a vector can be turned into a unit vector, namely by dividing by its norm, or size. If $f \in L^2[a, b]$, then the function g defined by

$$g(x) = \frac{f(x)}{\|f\|}$$

has unit norm. If each function in an orthogonal set of functions has unit norm, then the set is called **orthonormal** system. Thus, orthogonal systems functions can always be turned into orthonormal systems.

Example 3.4

The set of functions

$$\sin \frac{n\pi x}{l}, \quad n = 1, 2, \dots,$$

is orthogonal on the interval $[0, l]$, and $\|\sin \frac{n\pi x}{l}\|^2 = l/2$. Therefore, the functions

$$\sqrt{\frac{2}{l}} \sin \frac{n\pi x}{l}$$

form an orthonormal set of functions on $[0, l]$. An expansion of a function $f(x)$ defined on $[0, l]$ in terms of this set of orthonormal functions is called a **Fourier sine series**. \square

Convergence

The next question is a key one. Can an arbitrary function $f \in L^2$ be expanded in an infinite series of a given orthogonal system of functions f_1, f_2, f_3, \dots ? That is, can we write

$$f(x) = \sum_{n=1}^{\infty} c_n f_n(x) \quad (3.13)$$

for some set of constants c_n , and in what sense can we interpret the convergence of the series to $f(x)$? Physically, we think of (3.13) as decomposing a signal f into fundamental modes f_1, f_2, f_3, \dots . This is the same question that we asked in Section 3.1 regarding the feasibility of expanding a given initial temperature $f(x)$ into a sine series.

This question of convergence is of course not an issue in finite dimensional spaces. But in function spaces this is a delicate question and there are several possible answers, depending on how we measure error in a partial sum. Precisely, we formulate three types the errors that can occur in an N -term approximation

$$S_N(x) \equiv \sum_{n=1}^N c_n f_n(x)$$

to a function $f(x)$. Each of these error expressions leads to a different definition of convergence of the infinite series.

1. The **pointwise error** $E_N(x)$ is the function

$$E_N(x) \equiv f(x) - S_N(x) \equiv f(x) - \sum_{n=1}^N c_n f_n(x).$$

Thus, for a fixed number of terms N , $E_N(x)$ is a function whose values give the error at each point x . If for each *fixed* x in $[a, b]$ we have $\lim_{N \rightarrow \infty} E_N(x) = 0$, then we say that the infinite series (3.13) **converges pointwise** to f on the interval $[a, b]$; in this case, for each fixed x the series is a numerical series that converges to the numerical value $f(x)$, at that x . Pointwise convergence means that the error goes to zero at each point. This is the type of convergence that a calculus student first encounters.

2. The **mean-square error** in the approximation is the number e_N defined by

$$e_N \equiv \int_a^b |f(x) - S_N(x)|^2 dx \equiv \int_a^b |f(x) - \sum_{n=1}^N c_n f_n(x)|^2 dx.$$

Note that e_N is just the square of the pointwise error, integrated over the interval $[a, b]$. Thus, the mean-square error is an integrated average over all

the pointwise errors. We say that the infinite series (3.13) converges to f in the **mean-square** sense if

$$\lim_{N \rightarrow \infty} e_N = 0.$$

Mean-square convergence is also called **convergence in $L^2[a, b]$** . Thus, we can write the last line in terms of the norm as

$$\lim_{N \rightarrow \infty} \|f - S_N\|^2 = 0.$$

Note that we can remove the square on the norm, which is common. It requires that the integrated pointwise error-squared go to zero as more and more terms are taken. In advanced courses it is shown that pointwise convergence does not imply mean-square convergence, and conversely.

3. The **uniform error** ε_N is the maximum pointwise error over the interval $[a, b]$, or

$$\varepsilon_N = \max_{a \leq x \leq b} |f(x) - S_N(x)| = \max_{a \leq x \leq b} \left| f(x) - \sum_{n=1}^N c_n f_n(x) \right|.$$

Uniform convergence is a stronger type of convergence; it implies both mean-square and pointwise convergence. We say that the series (3.13) **converges uniformly** to $f(x)$ on $[a, b]$ if

$$\lim_{N \rightarrow \infty} \varepsilon_N = \lim_{N \rightarrow \infty} \left\{ \max_{a \leq x \leq b} |f(x) - S_N(x)| \right\} = 0.$$

Thus, for any given tolerance $\epsilon > 0$, we can find a number N (representing the number of terms) such that for all $n > N$ we have

$$\max_{a \leq x \leq b} |f(x) - S_n(x)| < \epsilon.$$

That is, the error can be made uniformly small over the entire interval by choosing the number of terms large enough. Uniform convergence depends only on the tolerance ϵ and not on the position in the interval where the error is calculated. [In some cases “max” must be replaced “sup” (for *supremum*); see an advanced calculus text, e.g., Spivak (2008).]

By the way, all of the definitions above are valid for series of functions, whether or not the functions $f_n(x)$ are mutually orthogonal.

Example 3.5

Investigate the convergence the series

$$\sum_{n=0}^{\infty} (-1)^n x^{2n}, \quad -1 < x < 1.$$

Here we can find the partial sums explicitly. We have

$$S_N(x) = \sum_{n=0}^N (-1)^n x^{2n} = \sum_{n=0}^N (-x^2)^n = \frac{1 - (-x^2)^{N+1}}{1 + x^2},$$

where we have used the geometric sum

$$1 + z + z^2 + z^3 + \cdots + z^N = \frac{1 - z^{N+1}}{1 - z}.$$

Simplifying,

$$S_N(x) = \frac{1 + (-1)^{N+2} x^{2(N+1)}}{1 + x^2} \rightarrow \frac{1}{1 + x^2}, \quad -1 < x < 1.$$

Therefore the series converges pointwise to $1/(1 + x^2)$ on $-1 < x < 1$.

To check uniform convergence we note that the uniform error is

$$\varepsilon_N = \max_{-1 < x < 1} \left| S_N(x) - \frac{1}{1 + x^2} \right| = \max_{-1 < x < 1} \frac{x^{2(N+1)}}{1 + x^2} = \frac{1}{2}.$$

This does not go to zero as $N \rightarrow \infty$, so the convergence is *not* uniform.

For mean-square convergence,

$$E_N = \int_{-1}^1 \left| s_N(x) - \frac{1}{1 + x^2} \right|^2 dx = \int_{-1}^1 \frac{x^{4N+4}}{(1 + x^2)^2} dx.$$

But, on the interval $-1 < x < 1$ we have $\frac{1}{(1+x^2)^2} \leq 1$. Therefore

$$E_N = \int_{-1}^1 \frac{x^{4N+4}}{(1 + x^2)^2} dx < \int_{-1}^1 x^{4N+4} dx = \frac{2}{4N + 5} \rightarrow 0, \quad \text{as } N \rightarrow \infty.$$

Therefore the series converges in the mean-square sense. \square

A novice may not appreciate subtle differences in convergence and wonder why we have defined three types (actually, there are others). Suffice it to say that the error may not go to zero in a pointwise or uniform manner, but that does not mean the approximation is not useful; a weaker form of convergence, like mean-square convergence, may be all that is required.

Now suppose (3.13) holds in the sense of mean-square convergence where f is a given function in L^2 and f_n is a *given orthogonal system* in L^2 . How can we

compute the coefficients c_n ? The demonstration here is exactly that which is given in Section 3.1 where we showed how to compute the coefficients in a sine series. Orthogonality is crucial. We assume in this argument that the series in (3.13) can be integrated term by term (it can be proved). If we multiply both sides of (3.13) by f_m , where m is a fixed, but arbitrary index, and integrate over the interval $[a, b]$, we get, using the inner product notation,

$$\begin{aligned}(f, f_m) &= \int_a^b \sum_{n=1}^{\infty} c_n f_n(x) f_m(x) dx \\ &= \sum_{n=1}^{\infty} c_n (f_n, f_m) \\ &= c_m (f_m, f_m) = c_m \|f_m\|^2.\end{aligned}$$

Note that the infinite sum collapsed to a single term because of the orthogonality of the f_n . So the c_n are given by

$$c_n = \frac{1}{\|f_n\|^2} (f, f_n), \quad n = 1, 2, \dots \quad (3.14)$$

We summarize in the following theorem.

Theorem 3.6

Let $f \in L^2[a, b]$ and $\{f_n\}$ be an orthogonal system of L^2 functions on $[a, b]$. If

$$f(x) = \sum_{n=1}^{\infty} c_n f_n(x) \quad (3.15)$$

in the mean square sense, then the coefficients c_n are given by (3.14). \square

The c_n are called the **Fourier coefficients**, and when the coefficients are computed in this way, the orthogonal series (3.15) is called the **generalized Fourier series** for f . In analogy with finite dimensional vector spaces, like \mathbb{R}^n , the Fourier coefficient c_n is interpreted as the projection of f onto the subspace defined by f_n .

Remark 3.7

If the series expansion (3.15) is valid in the mean-square sense and the f_n are **orthonormal**, then the Fourier coefficients (3.14) are given simply by

$$c_n = (f, f_n), \quad (f_n \text{ orthonormal}). \quad \square \quad (3.16)$$

There is another useful property of Fourier coefficients.

Theorem 3.8

(Best approximation) Let $\{c_n\}$ be the set of Fourier coefficients in the finite expansion of $f \in L^2[a, b]$ in the orthonormal system f_1, f_2, \dots, f_N . If $\{a_n\}$ is any other sequence of coefficients, then

$$\|f - \sum_{n=1}^N c_n f_n\|^2 \leq \|f - \sum_{n=1}^N a_n f_n\|^2. \quad (3.17)$$

That is, the mean-square error is minimized for the approximation with the Fourier coefficients c_n given by (3.16). \square

This result is called **best approximation**. It answers the question how we can best approximate f by a finite linear combination of the f_n . Just use the Fourier coefficients.

The demonstration of (3.17) is straightforward using the definition of norm and properties of the inner product. We have

$$\begin{aligned} \|f - \sum_{n=1}^N a_n f_n\|^2 &= \left(f - \sum_{n=1}^N a_n f_n, f - \sum_{n=1}^N a_n f_n \right) \\ &= (f, f) - 2 \sum_{n=1}^N a_n (f, f_n) + \sum_{n=1}^N a_n^2 \\ &= (f, f) - 2 \sum_{n=1}^N a_n c_n + \sum_{n=1}^N a_n^2 + \sum_{n=1}^N c_n^2 - \sum_{n=1}^N c_n^2 \\ &= (f, f) - \sum_{n=1}^N c_n^2 + \sum_{n=1}^N (a_n - c_n)^2 \\ &= \|f - \sum_{n=1}^N c_n f_n\|^2 + \sum_{n=1}^N (a_n - c_n)^2. \end{aligned}$$

Because the second term on the right is nonnegative, (3.17) is valid. If the f_n are not orthonormal, and just orthogonal, then the same result is true with the c_n given by (3.14). \square

In the last line of the proof we used the fact that

$$\|f - \sum_{n=1}^N c_n f_n\|^2 = \|f\|^2 - \sum_{n=1}^N c_n^2,$$

which the reader should verify. But this equality leads to another interesting inequality. Because the left side is nonnegative, we have

$$\sum_{n=1}^N c_n^2 \leq \|f\|^2.$$

This inequality is valid for each N , and so

$$\sum_{n=1}^{\infty} c_n^2 \leq \|f\|^2, \quad (\text{Bessel's Inequality})$$

which is **Bessel's inequality**. It shows that the series of squared Fourier coefficients converges, and thus $c_n \rightarrow 0$ as $n \rightarrow \infty$. So the Fourier coefficients get smaller and smaller.

Example 3.9

(Best approximation) Note that the set of functions $f_n(x) = \sin nx$ forms an orthogonal set of functions on $[0, \pi]$. Find the best approximation of the function $f(x) = 8x(\pi - x)e^{-x^2}$ of the form

$$c_1 \sin x + c_2 \sin 2x + c_3 \sin 3x + c_4 \sin 4x + c_5 \sin 5x.$$

We know that the c_n are the Fourier coefficients given by

$$c_n = \frac{(f, \sin nx)}{\|\sin nx\|^2} = \frac{2}{\pi} \int_0^{\pi} f(x) \sin nx \, dx.$$

Using a calculator we obtain

$$c_1 = 3.708, \quad c_2 = 4.040, \quad c_3 = 2.230, \quad c_4 = 0.798, \quad c_5 = 0.295.$$

The reader should plot $f(x)$ and the Fourier approximation on the interval $[0, \pi]$ to observe how much the two differ. \square

Note that all the previous results assume that $\sum c_n f_n$ converges in the mean square sense to f . So we need another result to round out our discussion: namely, if the $\{f_n\}$ form an orthonormal set and we form the generalized Fourier series (3.13) with c_n the Fourier coefficients given by (3.16), does the series automatically converge to f in one sense or another? The answer to the question is yes, in the mean-square sense, provided that the orthonormal system $\{f_n\}$ is complete.

Definition 3.10

An orthonormal system $\{f_n\}$ in L^2 is said to be **complete** if, and only if, there is *no* nontrivial $f \in L^2$ which is orthogonal to all the f_n . That is, if $(f, f_n) = 0$ for $n = 1, 2, 3, \dots$, then $f \equiv 0$. \square

Thus, an orthonormal sequence $\{f_n\}$ is complete if the only function having all its Fourier coefficients vanish is the zero function. Sometimes it is difficult to show completeness, and we shall just state whether a given orthonormal system is complete. It is shown in advanced treatments that completeness is equivalent to the property that *any* function $f \in L^2$ can be expanded in a generalized Fourier series (3.13), where the c_n are the Fourier coefficients, and that the series converges to f in the mean-square sense. Furthermore, it can be proved that completeness is equivalent to strict equality holding in the Bessel inequality; i.e., $\{f_n\}$ is complete if, and only if, for each $f \in L^2$,

$$\sum_{n=1}^{\infty} c_n^2 = \|f\|^2.$$

This equation is called **Parseval's equality**.

Pointwise convergence results, or even stronger uniform convergence results, are more difficult to obtain. Typically, for these these types of results continuity and differentiability conditions on the function f are required. We state these results in the next section for orthogonal, trigonometric systems.

We can extend the modal interpretation of the generalized Fourier series still further. We can think of f as a signal and the orthonormal set $\{f_n\}$ as fundamental modes. The Fourier coefficient c_n determines the contribution of the n th mode, and the generalized Fourier series is the decomposition of the signal into fundamental modes. The sequence of squared coefficients, $c_1^2, c_2^2, c_3^2, \dots$, is called the **energy spectrum**, and c_n^2 is called the energy of the n th mode; by Parseval's equality, the **total energy** in the signal is the norm-squared, $\|f\|^2$.

EXERCISES

The trigonometric identities

$$\begin{aligned}\sin a \sin b &= \frac{1}{2}(\cos(a - b) - \cos(a + b)) \\ \sin a \cos b &= \frac{1}{2}(\sin(a + b) + \sin(a - b)),\end{aligned}$$

along with others, are useful in the calculations.

1. Derive a trigonometric identity similar to the ones above for $\cos a \cos b$.

2. a) Verify that the set of functions $1, \cos x, \cos 2x, \dots$ forms an orthogonal system on the interval $[0, \pi]$.

- b) Verify that the set of functions

$$\cos\left(\frac{n\pi x}{l}\right), \quad n = 0, 1, 2, \dots,$$

form an orthogonal system on the interval $[0, l]$.

- c) If

$$f(x) = \sum_{n=0}^{\infty} c_n \cos\left(\frac{n\pi x}{l}\right)$$

in the mean-square sense on $[0, l]$, what is the formula for the c_n ? This series is called the **Fourier cosine series** for f on $[0, l]$.

3. Let $f(x) = 0$ for $0 < x < 1$ and $f(x) = 1$ for $1 < x < 3$.

- a) Find the first 4 nonzero terms of the Fourier cosine series of f .

- b) What is the sum of this series on $0 \leq x \leq 3$?

- c) Why does the series converge to $f(x)$ in the mean-square sense?

- d) Find the value of the infinite sum

$$1 + \frac{1}{2} - \frac{1}{4} - \frac{1}{5} + \frac{1}{7} + \frac{1}{8} - \frac{1}{10} - \frac{1}{11} + \dots$$

4. Consider the infinite series

$$\sum_{n=1}^{\infty} (1-x)x^{n-1}, \quad 0 < x < 1.$$

- a) Show that the series converges pointwise. Hint: Find the partial sums.

- b) Show that the convergence is not uniform.

- c) Show that the series converges in the mean-square sense.

5. Consider the infinite series

$$\sum_{n=1}^{\infty} \left(\frac{n}{1+n^2x^2} - \frac{n-1}{1+(n-1)^2x^2} \right), \quad 0 < x < 1.$$

- a) Show that the series converges pointwise. Hint: The series ‘telescopes.’

- b) Show that the convergence is not uniform.

- c) Show that the series does not converge in the mean-square sense.

6. If c_n are Fourier coefficients of f and f_n is an orthonormal set, show that

$$\left(\sum_{n=1}^N c_n f_n, f - \sum_{n=1}^N c_n f_n \right) = 0.$$

7. (**Gram–Schmidt orthogonalization**) We know from elementary linear algebra that any set of linearly independent vectors may be turned into a set of orthogonal vectors by the Gram–Schmidt orthogonalization process. The same process works for functions in $L^2[a, b]$. Let f_1, f_2, f_3, \dots be an independent set of functions in L^2 . Define the set of functions g_n by

$$g_1 = f_1, \quad g_2 = f_2 - \frac{(f_2, g_1)}{\|g_1\|^2} g_1, \quad g_3 = f_3 - \frac{(f_3, g_2)}{\|g_2\|^2} g_2 - \frac{(f_3, g_1)}{\|g_1\|^2} g_1, \dots$$

Show that g_n is an orthogonal set.

8. The functions $1, x, x^2, x^3$ are independent functions on the interval $[-1, 1]$.
- Use the preceding exercise to generate a set of four orthogonal polynomials $P_0(x), \dots, P_3(x)$ on $[-1, 1]$. These are called **Legendre polynomials**.

- b) Find the best approximation of e^x on $[-1, 1]$ of the form

$$e^x \approx c_0 P_0(x) + c_1 P_1(x) + c_2 P_2(x) + c_3 P_3(x).$$

- c) Plot e^x and the approximation on a set of coordinate axes.

- d) What is the pointwise error? What is the maximum pointwise error over $[-1, 1]$. What is the mean-square error?

9. For $f, g \in L^2[a, b]$, prove the **Cauchy–Schwarz inequality**

$$|(f, g)| \leq \|f\| \|g\|.$$

Hint: Define $Q(t) = (f + tg, f + tg)$ for any real number t . Use the rules of inner product to expand this expression and obtain a quadratic polynomial in t ; because $Q(t) \geq 0$ (why?), the quadratic polynomial can have at most one real root. Examine the discriminant of the polynomial.

10. Verify the Cauchy–Schwarz inequality for $f(x) = x$ and $g(x) = e^{-x}$ on $0 \leq x \leq 1$.
11. Let $f, g \in L^2[a, b]$. Show that the triangle inequality $\|f + g\| \leq \|f\| + \|g\|$ holds. Hint: Consider $\|f + g\|^2$.
12. For which powers r is the function $f(x) = x^r$ in $L^2[0, 1]$? In $L^2[1, \infty)$?

13. Let f be defined and integrable on $[0, l]$. The orthogonal expansion

$$\sum_{n=1}^{\infty} b_n \sin \frac{n\pi x}{l}, \quad b_n = \frac{2}{l} \int_0^l f(x) \sin \frac{n\pi x}{l} dx,$$

is called the **Fourier sine series** for f on $[0, l]$. Find the Fourier sine series for $f(x) = \cos x$ on $[0, \pi/2]$ and plot a 6-term approximation. What is the Fourier sine series of $f(x) = \sin x$ on $[0, \pi]$?

14. Find the numbers b_1, b_2, b_3 such that

$$y(x) = b_1 \sin \frac{\pi x}{2} + b_2 \sin \frac{2\pi x}{2} + b_3 \sin \frac{2\pi x}{2}$$

is the best approximation to $f(x) = 1$ on $(0, 2)$. Draw a plot of the approximation.

15. Expand the function $f(x) = 1$ on $[0, 1]$ in a Fourier sine series and derive the interesting formula

$$\frac{\pi}{4} = \sin 1 + \frac{1}{3} \sin 3 + \frac{1}{5} \sin 5 + \dots$$

3.3 Classical Fourier Series

In the last section we introduced the concept of representing a given function $f(x)$ in terms of an infinite series of orthogonal functions $f_n(x)$. Now we focus those concepts on a special set of orthogonal functions where the f_n are given by sines and cosines. The resulting series is called a (classical) **Fourier series**, or **trigonometric series**. In this section we drop the adjective “classical.” To contrast it with Fourier cosine and Fourier sine series, sometimes we refer to it as the full Fourier series.

We work on an arbitrary symmetric interval $[-l, l]$ about the origin. If f is an integrable function on $[-l, l]$, then its **Fourier series** is

$$\frac{a_0}{2} + \sum_{n=1}^{\infty} \left(a_n \cos \frac{n\pi x}{l} + b_n \sin \frac{n\pi x}{l} \right), \quad (3.18)$$

where the **Fourier coefficients** a_n and b_n are given by the formulas

$$a_n = \frac{1}{l} \int_{-l}^l f(x) \cos \frac{n\pi x}{l} dx, \quad n = 0, 1, 2, \dots, \quad (3.19)$$

$$b_n = \frac{1}{l} \int_{-l}^l f(x) \sin \frac{n\pi x}{l} dx, \quad n = 1, 2, \dots \quad (3.20)$$

Here, the set of functions

$$\frac{1}{2}, \cos \frac{n\pi x}{l}, \sin \frac{n\pi x}{l}, \quad n = 1, 2, \dots, \quad (3.21)$$

forms an orthogonal system on the interval $[-l, l]$. They are playing the role of the $f_n(x)$ in formula (3.13), and the a_n and b_n are playing the role of the coefficients c_n . It is shown in more advanced texts that the set of functions (3.21) is complete, and therefore the Fourier series (3.18) converges in the mean-square sense to f when $f \in L^2[-l, l]$.

Example 3.11

Let $f(x) = x$ for $-l \leq x \leq l$. Then the Fourier coefficients are easily computed using integration by parts to get

$$a_n = \frac{1}{l} \int_{-l}^l x \cos \frac{n\pi x}{l} dx = 0, \quad n = 0, 1, 2, \dots,$$

$$b_n = \frac{1}{l} \int_{-l}^l x \sin \frac{n\pi x}{l} dx = \frac{2l}{n\pi} (-1)^{n+1}, \quad n = 1, 2, \dots$$

Therefore the Fourier series for f is

$$\frac{2l}{\pi} \left(\sin \frac{\pi x}{l} - \frac{1}{2} \sin \frac{2\pi x}{l} + \frac{1}{3} \sin \frac{3\pi x}{l} - \dots \right).$$

We make two observations. First, at $x = \pm l$ the series clearly converges to zero and thus does not converge to $f(x)$ at these two points. So the series does not converge pointwise to $f(x)$ on the interval $[-l, l]$. It does, however, converge pointwise to $f(x) = x$ on $(-l, l)$. Second, the derived series obtained by differentiating term-by-term,

$$2 \sum_{n=1}^{\infty} (-1)^{n+1} \cos \frac{n\pi x}{l},$$

does not converge at all, much less to the derivative $f'(x) = 1$. (Notice the n th term does not go to zero.) So the series cannot be differentiated term by term. We do know from Section 3.2 that the series converges to f in the mean-square sense. \square

For the Fourier series (3.18) we define the n th **harmonic** to be

$$a_n \cos \frac{n\pi x}{l} + b_n \sin \frac{n\pi x}{l}.$$

Each harmonic in the series has a higher frequency (and thus more oscillations) than the preceding harmonic. The **frequency spectrum** of the series is the sequence of numbers γ_n defined by

$$\gamma_0 = \frac{|a_0|}{\sqrt{2}}, \quad \gamma_n = \sqrt{a_n^2 + b_n^2} \quad (n \geq 1).$$

The frequency spectrum is a measure of the contribution of the various harmonics in the decomposition of f . The numbers γ_n^2 , $n \geq 0$, form the **energy spectrum**. The reader is invited to show that **Parseval's equality** takes the form

$$\frac{a_0^2}{2} + \sum_{n=1}^{\infty} (a_n^2 + b_n^2) = \frac{1}{l} \|f\|^2.$$

The frequency spectrum for $f(x) = x$ in the last example is $\gamma_0 = 0$, $\gamma_n = 2l/(n\pi)$, $n \geq 1$. It is often graphed, as in Figure 3.2, to show visually the contribution of each harmonic.

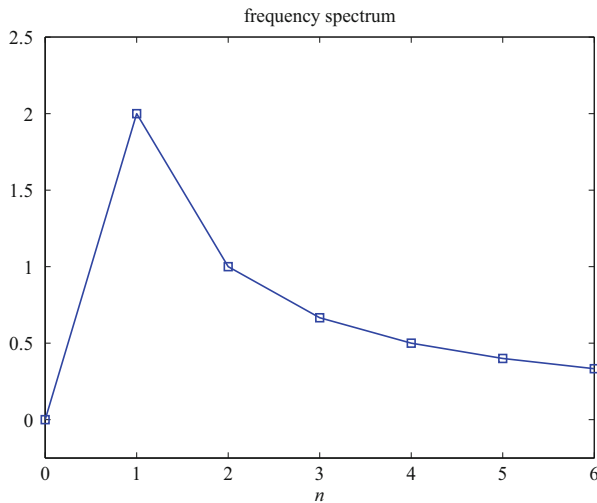

Figure 3.2 Frequency spectrum for the function $f(x) = x$ on $[-\pi, \pi]$

A Fourier series simplifies considerably if f is an even or an odd function. First observe that $\sin \frac{n\pi x}{l}$ is an odd function and $\cos \frac{n\pi x}{l}$ is an even function; moreover, an even function times an odd function is odd. Therefore, if f is an even function, then the product $f(x) \sin \frac{n\pi x}{l}$, which is the integrand in the expression for b_n in (3.18), is an odd function; so all of the coefficients b_n are

zero because an odd function integrated over a symmetric interval about the origin is zero. Hence:

If f is an even function, then its Fourier series reduces to a cosine series having the form

$$\frac{a_0}{2} + \sum_{n=1}^{\infty} a_n \cos \frac{n\pi x}{l},$$

$$a_n = \frac{2}{l} \int_0^l f(x) \cos \frac{n\pi x}{l} dx, \quad n = 0, 1, 2, \dots$$

Similarly,

If f is an odd function, then the coefficients a_n in (3.18) vanish, and the Fourier series reduces to a sine series

$$\sum_{n=1}^{\infty} b_n \sin \frac{n\pi x}{l}.$$

$$b_n = \frac{2}{l} \int_0^l f(x) \sin \frac{n\pi x}{l} dx, \quad n = 1, 2, \dots$$

This last fact is illustrated in the previous example, where we found the Fourier sine series for $f(x) = x$, an odd function.

Periodic functions on \mathbb{R}

Given any integrable function on $(-l, l)$, we can always form its full Fourier series (3.18). However, the Fourier series (3.18) itself is a $2l$ -periodic function, meaning that it repeats its values every interval of length $2l$. (Recall that a function ϕ is P -periodic, or periodic of period P , if it repeats itself in every interval of length P ; that is, $f(x + P) = f(x)$ for all x .) This means that the Fourier series represents not only the function f on $(-l, l)$, but also represents its $2l$ **periodic extension** to the entire real line. The $2l$ periodic extension of f is found by plotting the graph of f on $(-l, l)$ and then translating its graph to the left and to the right to every interval of length $2l$; that is, to the intervals $(l, 3l)$, $(3l, 5l)$, \dots , $(-3l, -l)$, $(-5l, -3l)$, \dots . See Figure 3.3.

If a function f is defined only on $(0, l)$, then we can extend it to an even function on $(-l, l)$. See Figure 3.4. This is called its **even extension**. In this case, the full Fourier series reduces to a cosine series. If we extend f to an odd function on $(-l, l)$, the so-called odd extension (see Figure 3.5), then its full Fourier series reduces to a sine series.

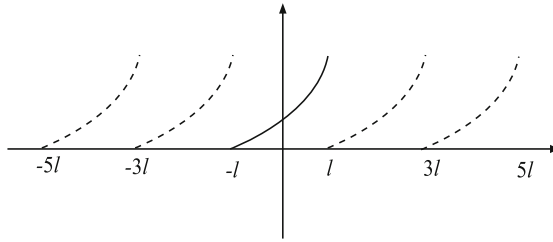

Figure 3.3 A function f defined on $(-l, l)$ (*solid*) and its $2l$ -periodic extension (*dashed*)

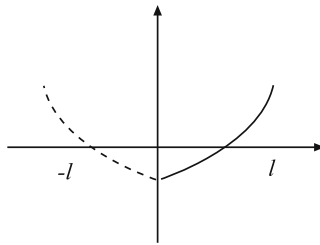

Figure 3.4 A function f defined on $(0, l)$ (*solid*) and its even extension (*dashed*) to $(-l, l)$

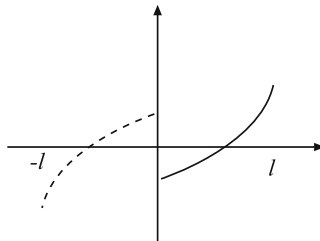

Figure 3.5 A function f defined on $(0, l)$ (*solid*) and its odd extension (*dashed*) to $(-l, l)$

Example 3.12

Consider the 2-periodic signal shown in Figure 3.6, which is called a triangular wave. Analytically it is given by $f(x) = x + 1$ if $-1 < x \leq 0$; $f(x) = 1 - x$ if $0 < x \leq 1$; and otherwise 2-periodic. We compute its Fourier series. Here, f is an even function, and so $b_n = 0$ for all n . The coefficients a_n are given by

$$\begin{aligned} a_n &= \int_{-1}^1 f(x) \cos n\pi x dx \\ &= \int_{-1}^0 (x + 1) \cos n\pi x dx + \int_0^1 (1 - x) \cos n\pi x dx. \end{aligned}$$

When $n = 0$, we easily get $a_0 = 1$. For $n \geq 1$ we can calculate a_n by hand (using integration by parts), use a calculator, or use a computer algebra package. The first five coefficients are

$$a_1 = 0.405, \quad a_2 = 0, \quad a_3 = 0.045, \quad a_4 = 0, \quad a_5 = 0.016.$$

Therefore, a four-term Fourier approximation to the triangular wave is

$$f(x) \approx 0.5 + 0.405 \cos \pi x + 0.045 \cos 3\pi x + 0.016 \cos 5\pi x.$$

Figure 3.6 shows a plot of f and its approximation. From the last section we know that this approximation is the best, in the mean-square sense. \square

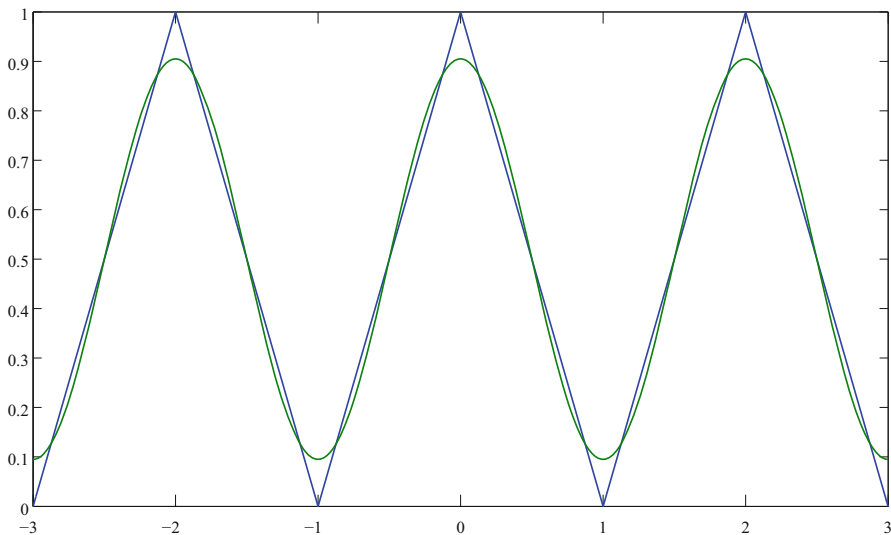

Figure 3.6 A triangular wave and its 4-term Fourier expansion

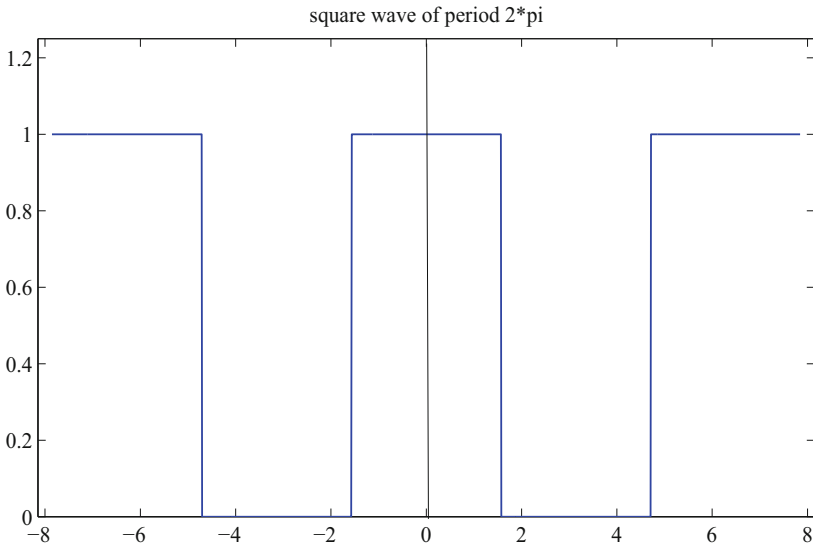

Figure 3.7 Graph of a 2π -periodic square wave. See Exercise 1

Remark 3.13

(Exponential form of Fourier Series) Using the fact that sine and cosine functions may be written in terms of the complex exponential function, that is,

$$\cos \theta = \frac{1}{2} (e^{i\theta} + e^{-i\theta}), \quad \sin \theta = \frac{1}{2i} (e^{i\theta} - e^{-i\theta}),$$

it is evident that the full Fourier series for a function f on $(-l, l)$ can be written in exponential form as

$$f(x) = \sum_{n=-\infty}^{\infty} c_n e^{in\pi x/l}.$$

It is not hard to see that

$$\int_{-l}^l e^{in\pi x/l} e^{-im\pi x/l} dx = \begin{cases} 0, & m \neq n \\ 2l, & m = n \end{cases}.$$

(Note the minus sign on the second factor in the integral.) This entails a modification of the definition of the inner product for complex-valued functions to

$$(f, g) = \int_{-l}^l f(x) \overline{g(x)} dx,$$

where the *overbar* means complex conjugation. By previous methods we find that the complex Fourier coefficients are given by

$$c_n = \frac{1}{2l} \int_{-l}^l f(x) e^{-in\pi x/l} dx.$$

The complex form is useful in many calculation involving exponential and hyperbolic functions. We can always return to the real Fourier series by isolating the real and imaginary parts of the series. \square

Finally we make some comments about convergence of Fourier series. We already noted that if f is square integrable, then mean-square convergence is automatic. To obtain pointwise convergence results some additional assumptions must be made regarding the smoothness of f . Our assumption is that the graph of f is made up of finitely many smooth pieces; the function is not necessarily continuous. This will cover most of the interesting functions encountered in science and engineering. A function f is **piecewise continuous** on $[a, b]$ if it is continuous except possibly at a finite number of points in $[a, b]$ where it has simple jump discontinuities; f has a simple jump discontinuity at $x = c$ if both one-sided limits $f(c^+)$ and $f(c^-)$ exist and are finite at c . The function may or may not be defined at a jump discontinuity. We say f is **piecewise smooth** on $[a, b]$ if both f and f' are piecewise continuous on $[a, b]$. We say f is piecewise smooth on $(-\infty, \infty)$ if it is piecewise smooth on each bounded subinterval $[a, b]$ of the real line. Then the basic pointwise convergence theorem is the following:

Theorem 3.14

(Pointwise convergence) If f is piecewise smooth on $[-l, l]$ and otherwise $2l$ -periodic, then its Fourier series (3.18) converges pointwise for all $x \in \mathbb{R}$ to the value $f(x)$ if f is continuous at x , and to the average value of its left and right limits at x , namely $\frac{1}{2}(f(x^-) + f(x^+))$, if f is discontinuous at x . \square

To get stronger convergence results, like uniform convergence, additional smoothness conditions on f are required. Also, continuity of f is not enough to guarantee pointwise convergence; incredible as it may seem, there are continuous functions whose Fourier series diverge at every point! Next is a basic result for uniform convergence of the Fourier series for a given function.

Theorem 3.15

(Uniform convergence) Let f be a continuous function on the interval $[-l, l]$ with $f(-l) = f(l)$, and suppose its derivative is piecewise continuous on that interval. Then the Fourier series

$$a_0 + \sum_{n=1}^{\infty} \left(a_n \cos \frac{n\pi x}{l} + b_n \sin \frac{n\pi x}{l} \right)$$

converges absolutely and uniformly to $f(x)$ on that interval. \square

EXERCISES

1. Find the Fourier series for the 2π -periodic square wave shown in Figure 3.7. Sketch a two-term, a four-term, and a six-term approximation.
2. Show that the Fourier cosine series for $\sin x$ on $0 < x < \pi$ is

$$\frac{2}{\pi} - \frac{4}{\pi} \sum_{n=1}^{\infty} \frac{\cos 2nx}{4n^2 - 1}$$

Show graphically the function represented by the series on the interval $(-\pi, \pi)$. On the entire real line?

3. Find the Fourier series for $f(x) = x^2$ on $[-\pi, \pi]$. Sketch a graph of the function defined on all of \mathbb{R} to which the Fourier series converges. Is the convergence pointwise? Use the Fourier series to show

$$\frac{\pi^2}{12} = 1 - \frac{1}{4} + \frac{1}{9} - \frac{1}{16} + \cdots$$

Graph the frequency spectrum.

4. Derive the series representation

$$\frac{\pi^2}{8} = \sum_{n=1}^{\infty} \frac{1}{(2n-1)^2}$$

using the function $f(x) = |x|$, $-\pi \leq x \leq \pi$.

5. Find the Fourier sine series of $f(x) = \pi - x$ on $(0, \pi)$.
6. Let $f(x) = 1$, $0 < x < \pi/2$ and $f(x) = 0$, $\pi/2 < x < \pi$. Find the Fourier cosine series and the Fourier sine series. What is the full Fourier series? Explicitly characterize the values of $x \in \mathbb{R}$ where each converges pointwise.
7. Consider the function (signal) defined by $f(x) = x+1$ for $-2\pi < x \leq 0$ and $f(x) = x$ for $0 < x \leq 2\pi$, and otherwise 4π periodic. Sketch a graph of the signal and find its Fourier series. Find and graph the frequency spectrum. To what value does the Fourier series converge at $x = 0$? At $x = 2\pi$? At $x = \pi$? Graph the sum of the first four harmonics and observe how well it approximates f .
8. Show that for all x in $(0, 1)$,

$$\cos \pi x = \frac{8}{\pi} \sum_{n=1}^{\infty} \frac{n}{4n^2 - 1} \sin 2n\pi x.$$

9. Show that

$$e^x = \frac{\sinh \pi}{\pi} \sum_{n=-\infty}^{\infty} \frac{(-1)^n}{1 - in} e^{inx}$$

for $\pi < x < \pi$. Write the series in real quantities.

10. Show that the Fourier series for $f(x) = \cos ax$ on $[-\pi, \pi]$, where a is not an integer, is

$$\cos ax = \frac{2a \sin a\pi}{\pi} \left(\frac{1}{2a^2} + \sum_{n=1}^{\infty} (-1)^n \frac{\cos nx}{a^2 - n^2} \right).$$

Show

$$\csc a\pi = \frac{1}{a\pi} + \frac{2a}{\pi} \sum_{n=1}^{\infty} (-1)^n \frac{1}{n^2 - a^2}.$$

11. Let $f(x) = -\frac{1}{2}$ on $-\pi < x \leq 0$ and $f(x) = \frac{1}{2}$ on $0 \leq x \leq \pi$. Show that the Fourier series for f is

$$\sum_{n=1}^{\infty} \frac{2}{(2n-1)\pi} \sin(2n-1)x.$$

If $s_N(x)$ denotes the sum of the first N terms, sketch a graph of $s_1(x)$, $s_3(x)$, $s_7(x)$, and $s_{10}(x)$ and compare to $f(x)$. Observe that the approximations overshoot $f(x)$ in a neighborhood of $x = 0$, and the overshoot is not improved regardless of how many terms are taken in the approximation. This overshoot behavior of Fourier series near a discontinuity is called **Gibbs phenomenon**. The series does converge pointwise to $f(x)$ on $(-\pi, 0)$ and on $(0, \pi)$. At $x = 0$ it converges pointwise to the average of the left and right limits, or zero. It does not converge uniformly on any interval containing $x = 0$.

12. Show that the Fourier sine series of $f(x) = 100$ on $[0, l]$ is

$$\frac{4}{100} \left(\sin(\pi x/l) + \frac{1}{3} \sin(3\pi x/l) + \frac{1}{5} \sin(5\pi x/l) + \cdots \right).$$

Using software, plot the first 50 terms of the series on the scaled interval $0 \leq x/l \leq 1$. Observe Gibbs phenomena at the points $x/l = 0$ and $x/l = 1$, and calculate the percentage of the maximum overshoot at those two points. (Answer: about 9%.)

13. Find the complex form of the full Fourier series for $\cosh x$ on $(-1, 1)$. Find the real form.

4

Partial Differential Equations on Bounded Domains

This chapter treats a standard and important method called **separation of variables**, or the method of **eigenfunction expansions**, for solving partial differential equations on bounded spatial domains. This method, due to Fourier in the early 1800s, with contributions by Euler and D'Alembert in the late 1700s, is fundamental. In fact, many textbooks emphasize this method over all others because of its extensive applications in physics and engineering where most problems are on bounded spatial domains. In a nutshell, the essential feature of the method is the replacement of the partial differential by a set of ordinary differential equations which then are solved subject to given initial and boundary conditions. To fix the idea, assume the unknown function in the PDE is a $u = u(x, t)$, where the independent variables are x and t . We make the assumption that u can be written as a *product* of a function of x and a function of t , that is,

$$u(x, t) = y(x)g(t).$$

If the method is to be successful, when this product is substituted into the PDE, the PDE *separates* into two ODEs, one for $y(x)$ and one for $g(t)$. Substitution of the product into the boundary conditions leads to boundary conditions on the function $y(x)$. Therefore, we are faced with a spatial ODE boundary value problem for $y(x)$ and a temporal ODE problem for $g(t)$. When the equations for $y(x)$ and $g(t)$ are solved, we can form a product solution $u(x, t) = y(x)g(t)$ of the PDE that satisfies the boundary conditions. The boundary value problem we obtain for $y(x)$ is a special type of eigenvalue problem called a

Sturm–Liouville problem and it has infinitely many solutions. Consequently, we will have infinitely many product solutions $u_1(x, t)$, $u_2(x, t)$, $u_3(x, t)$, \dots that satisfy the boundary conditions. By superimposing these solutions, or adding them up in a special way, we determine a solution of the PDE and boundary conditions that *also* satisfies the initial condition(s). In other words, we form the series

$$u(x, t) = c_1 u_1(x, t) + c_2 u_2(x, t) + c_3 u_3(x, t) + \dots$$

and choose the constants c_n such that the sum satisfies the initial condition(s) as well. The result of the calculation is an infinite series representation of the solution to the the original initial boundary value problem for the PDE.

Section 1 amplifies the preceding remarks to fully motivate the method. Then, Section 2 presents the basics of Sturm–Liouville eigenvalue problems, and the final sections of the chapter treat many important examples that occur in engineering and physics. Many references discuss these methods in detail; particularly we mention Churchill (1963), and subsequent editions, Strauss (1992), Farlow (1993), and Haberman (2013).

4.1 Overview of Separation of Variables

In this first section we work through detailed examples of Fourier’s method in the contexts of heat transfer and wave motion.

Example 4.1

We revisit the basic idea of Fourier that we discussed in Section 3.1, which motivated the study of orthogonal expansions and Fourier series. Consider the initial boundary value problem for heat conduction,

$$u_t = u_{xx}, \quad 0 < x < \pi, \quad t > 0, \quad (4.1)$$

$$u(0, t) = u(\pi, t) = 0, \quad t > 0, \quad (4.2)$$

$$u(x, 0) = f(x), \quad 0 < x < \pi. \quad (4.3)$$

The separation of variables method consists of looking for solutions in the form of products, i.e.,

$$u(x, t) = y(x)g(t).$$

Substituting this product into the PDE (4.1) and boundary conditions (4.2), we obtain

$$y(x)g'(t) = y''(x)g(t), \quad y(0)g(t) = 0, \quad y(\pi)g(t) = 0.$$

Because $g(t)$ is not the zero function, we can write the ODE and boundary conditions as

$$\frac{g'(t)}{g(t)} = \frac{y''(x)}{y(x)} = -\lambda, \quad y(0) = y(\pi) = 0,$$

for some yet to be determined constant λ . This is valid because the only way a function of t can equal a function of x for all t and x , is if both are equal to the same constant. The yet unknown constant $-\lambda$ is called the **separation constant**; placing a minus sign on the constant is for convenience and does not mean that it is negative. Therefore, we obtain an ordinary differential equation for g in the time domain, namely,

$$g'(t) = -\lambda g(t),$$

and we obtain a boundary value problem for y in the spatial domain, namely,

$$-y''(x) = \lambda y(x), \quad 0 < x < \pi, \quad (4.4)$$

$$y(0) = 0, \quad y(\pi) = 0. \quad (4.5)$$

Therefore, the PDE problem separated into two ODE problems, one for $g(t)$ and one for $y(x)$. We can easily solve the the DE for g ; leaving out the arbitrary multiplicative constant, its solution is

$$g(t) = e^{-\lambda t}.$$

Next we solve the boundary value problem, which, as we later observe, is a special case of a Sturm–Liouville problem: It is obvious that $y(x) = 0$ is a solution to this problem; but we are interested in nontrivial solutions. The question is: *for which values of the separation constant λ are there nontrivial solutions?* (For example, if $\lambda = 2$ then the general solution is $y(x) = A \cos \sqrt{2}x + B \sin \sqrt{2}x$ which is not zero at $x = 0$ and $x = \pi$ unless $A = B = 0$.) One way to determine such values of λ is to write the general solution of (4.4) and go through a case argument by separately considering $\lambda = 0$, $\lambda > 0$, and $\lambda < 0$. We examine different cases because the general solution of (4.4) has a different form depending on the sign of λ . (We prove later that λ cannot be a complex number.) If $\lambda = 0$, then the ODE (4.4) has the form $y'' = 0$, whose general solution is the linear function $y(x) = Ax + B$. But the boundary condition $y(0) = 0$ implies $B = 0$, and then $y(\pi) = 0$ implies $A = 0$. Hence, in this case we get only the uninteresting trivial solution and so $\lambda = 0$ is not a possible value. If $\lambda < 0$, say for definiteness $\lambda = -\alpha^2$, then the ODE (4.4) has the form $y'' - \alpha^2 y = 0$, which has a general solution

$$y(x) = Ae^{\alpha x} + Be^{-\alpha x}.$$

The boundary conditions (4.5) force

$$\begin{aligned}y(0) &= A + B = 0, \\y(\pi) &= Ae^{\alpha\pi} + Be^{-\alpha\pi} = 0.\end{aligned}$$

It is easy to see that these two equations for A and B force $A = B = 0$, and again we obtain only the trivial solution. Thus, we must have $\lambda > 0$, or $\lambda = \alpha^2$. In this case the ODE (4.4) takes the form

$$y'' + \alpha^2 y = 0,$$

which has solutions built from sines and cosines:

$$y(x) = A \cos \alpha x + B \sin \alpha x.$$

First, $y(0) = 0$ forces $A = 0$. Thus $y(x) = B \sin \alpha x$. The right-hand boundary condition yields

$$y(\pi) = B \sin \alpha\pi = 0.$$

But now we are not required to take $B = 0$; rather, we can select α , and hence the unknown λ , to make this equation hold. Clearly, because the sine function vanishes at multiples of π , we have $\alpha = n$, a nonzero positive integer, or

$$\lambda = \lambda_n = n^2, \quad n = 1, 2, \dots$$

These are the values of λ that lead to nontrivial solutions

$$y = y_n(x) = \sin nx, \quad n = 1, 2, \dots$$

Here we arbitrarily selected the constant $B = 1$; but we can always multiply this solution by any constant to get another (not independent) solution.

These special values of λ for which (4.4–4.5) has a nontrivial solution are called the **eigenvalues** for the problem and the corresponding solutions $y_n(x)$ are called the **eigenfunctions**. For example, $\lambda = 1$ has corresponding eigenfunction $y_1(x) = \sin x$, $\lambda = 4$ has corresponding eigenfunction $y_1(x) = \sin 2x$, and so on. Observe further that the *eigenfunctions form an orthogonal system on the interval* $[0, \pi]$; the eigenfunctions we found are the basis of a Fourier sine series studied in the last chapter.

Next we return to the time equation which has solutions $g(t) = e^{\lambda t}$. Substituting the known values of $\lambda = \lambda_n$ gives

$$g_n(t) = e^{-n^2 t}, \quad n = 1, 2, \dots$$

Therefore, product solutions to the PDE and boundary conditions (4.1–4.2) are

$$u_n(x, t) = g_n(t)y_n(x) = e^{-n^2 t} \sin nx, \quad n = 1, 2, \dots$$

To find a solution that also satisfies the initial condition (4.3), we use superposition and form the linear combination

$$u(x, t) = \sum_{n=1}^{\infty} b_n e^{-n^2 t} \sin nx, \quad (4.6)$$

where the b_n are arbitrary constants. Equation (4.3) implies

$$u(x, 0) = f(x) = \sum_{n=1}^{\infty} b_n \sin nx.$$

The right side is the Fourier sine series for the initial function $f(x)$ in terms of the orthogonal functions $\sin nx$! From Chapter 3 we conclude that the coefficients b_n are the Fourier coefficients given by

$$b_n = \frac{2}{\pi} \int_0^{\pi} f(x) \sin nx \, dx. \quad (4.7)$$

In summary, the solution to initial boundary value problem (4.1), (4.2), (4.3) is given by the infinite series (4.6) where the b_n are given by (4.7). \square

This is the method of separation of variables, and it applies to most all of the problems on bounded domains in this text. For the method to work:

1. The boundary conditions must be homogeneous.
2. The PDE must be homogeneous.

Later in this chapter we indicate how to deal with nonhomogeneous problems.

Example 4.2

We apply the procedure, but with less detail, to the initial boundary value problem for the heat equation

$$u_t = k u_{xx}, \quad 0 < x < l, \quad t > 0, \quad (4.8)$$

$$u(0, t) = 0, \quad u(l, t) = 0, \quad t > 0, \quad (4.9)$$

$$u(x, 0) = f(x), \quad 0 < x < l, \quad (4.10)$$

where we have included a diffusivity k in the PDE and the spatial interval is $[0, l]$ instead of $[0, \pi]$.

Step one is to assume a solution of the form $u(x, t) = y(x)g(t)$ and substitute it into the PDE (4.8) and boundary conditions (4.9). Substituting into the PDE gives

$$y(x)g'(t) = ky''(x)g(t),$$

or, upon dividing by kyg ,

$$\frac{g'(t)}{kg(t)} = \frac{y''(x)}{y(x)}.$$

Notice that the variables in the equations have been separated—the left side is a function of t , and the right side is a function of x . Now, when can a function of t be equal to a function of x for all $x \in (0, l)$ and all $t > 0$? Only if the two functions are equal to the same constant, which again we call $-\lambda$. That is, we must have

$$\frac{g'(t)}{kg(t)} = -\lambda, \quad \frac{y''(x)}{y(x)} = -\lambda.$$

Therefore, we have two ODEs, for g and y :

$$g'(t) = -\lambda kg(t), \quad -y''(x) = \lambda y(x).$$

Also observe we placed the constant k in the g equation; it could be placed in the y equation, but it is convenient to keep the y equation simple. Next we substitute $u(x, t) = y(x)g(t)$ into the boundary conditions (4.9) to obtain

$$y(0)g(t) = 0, \quad y(l)g(t) = 0.$$

Excluding the uninteresting possibility that $g(t) = 0$, we get $y(0) = 0$ and $y(l) = 0$. Therefore, we are led to the boundary value problem

$$-y''(x) = \lambda y(x), \quad 0 < x < l, \quad (4.11)$$

$$y(0) = 0, \quad y(l) = 0. \quad (4.12)$$

This is an ODE boundary value problem for y . Exactly as in Example 4.1, the eigenvalues λ are positive. When $\lambda = \alpha^2$, the problem becomes

$$y'' + \alpha^2 y = 0, \quad y(0) = 0, \quad y(l) = 0.$$

The general solution is

$$y(x) = A \cos \alpha x + B \sin \alpha x.$$

Now $y(0) = 0$ forces $A = 0$ and then $y(l) = 0$ forces $B \sin \alpha l = 0$. We do not want to take $B = 0$, so we get $\alpha l = n\pi$, or $\alpha = n\pi/l$. Therefore, the eigenvalues are

$$\lambda = \lambda_n = \frac{n^2 \pi^2}{l^2}, \quad n = 1, 2, \dots, \quad (4.13)$$

and the corresponding solutions, or eigenfunctions, to the BVP are

$$y_n(x) = \sin \frac{n\pi x}{l}, \quad n = 1, 2, \dots \quad (4.14)$$

To reiterate, the eigenvalues are those values of λ for which the problem (4.11–4.12) has a nontrivial solution; the eigenfunctions are the corresponding nontrivial solutions.

The next step is to solve the time equation for $g(t)$. We easily get

$$g'(t) = -\lambda k g(t) \Rightarrow g(t) = e^{-\lambda k t} = e^{-n^2 \pi^2 k t / l^2}.$$

Now we put together the preceding results. We have constructed infinitely many product solutions of the PDE (4.8) having the form

$$u_n(x, t) = e^{-n^2 \pi^2 k t / l^2} \sin \frac{n \pi x}{l}, \quad n = 1, 2, \dots$$

These product solutions also clearly satisfy the boundary conditions (4.9), but they do not satisfy the given initial condition (4.10). So the next step is to determine the constants c_n such that the linear combination

$$u(x, t) = \sum_{n=1}^{\infty} c_n e^{-n^2 \pi^2 k t / l^2} \sin \frac{n \pi x}{l} \quad (4.15)$$

satisfies the initial condition (4.10). Thus we require

$$u(x, 0) = f(x) = \sum_{n=1}^{\infty} c_n \sin \frac{n \pi x}{l}.$$

But the right side is just the Fourier sine series of the function $f(x)$ on the interval $(0, l)$. Therefore, the coefficients c_n are the Fourier coefficients given by (see Section 3.3)

$$c_n = \frac{2}{l} \int_0^l f(x) \sin \frac{n \pi x}{l} dx, \quad n = 1, 2, \dots \quad (4.16)$$

Therefore, we have obtained a solution to (4.8–4.10) given by the infinite series (4.15) where the coefficients c_n are given by (4.16). If the function f is complicated, then a simple formula for the Fourier coefficients c_n cannot be found, and we must resort to numerical integration. \square

Remark 4.3

We can obtain a particularly insightful formula for the solution in Example 4.2. Substituting the expression for the c_n into the solution formula (4.15) allows

us to write the solution in a different way as

$$\begin{aligned} u(x, t) &= \sum_{n=1}^{\infty} \left(\frac{2}{l} \int_0^l f(\xi) \sin \frac{n\pi\xi}{l} d\xi \right) e^{-n^2\pi^2 kt/l^2} \sin \frac{n\pi x}{l} \\ &= \int_0^l \left(\frac{2}{l} \sum_{n=1}^{\infty} e^{-n^2\pi^2 kt/l^2} \sin \frac{n\pi\xi}{l} \sin \frac{n\pi x}{l} \right) f(\xi) d\xi \\ &\equiv \int_0^l g(x, \xi, t) f(\xi) d\xi. \end{aligned}$$

The function $g(x, \xi, t)$ is the expression in parentheses and is called the **Green's function** for the problem. This formula shows the form of the solution as an integral operator acting on the initial temperature distribution function f . Similar to the discussion in Chapter 2 on the diffusion equation, we can regard $g(x, \xi, t)f(\xi)$ as the temperature response at x , at time t , of the system due to a local source $f(\xi)$ at the point ξ at time $t = 0$; then the formula above adds up the contribution of all of the sources in the interval. In this way, the function $g(x, \xi, t)$ can be interpreted as a **source function**, or the response to a 'point source.' This may remind more advanced readers of delta functions. \square

Once a series representation for the solution is found, the work is not over if we want to find temperature profiles or the solution surface. Because we cannot sum an infinite series, we often take the first few terms as an approximation. Such approximations are illustrated in an example below and in the exercises. For the heat equation, taking a two or three term approximation is very accurate because of the decaying exponential in the series (4.15).

Example 4.4

Consider the initial boundary value problem for the heat equation:

$$\begin{aligned} u_t &= u_{xx}, & 0 < x < 1, & t > 0, \\ u(0, t) &= u(1, t) = 0, & t > 0, \\ u(x, 0) &= 10x^3(1-x), & 0 < x < 1. \end{aligned}$$

Here, $k = l = 1$ and the initial temperature is $f(x) = 10x^3(1-x)$. The solution is given by (4.15) with the coefficients (4.16) in Example 4.2. Specifically,

$$c_n = 20 \int_0^1 x^3(1-x) \sin(n\pi x) dx.$$

Using a computer algebra system or calculator, one finds

$$c_1 = 0.7331, \quad c_2 = -0.4838, \quad c_3 = 0.1304.$$

A 3-term approximate solution is therefore

$$u(x, t) \approx c_1 e^{-\pi^2 t} \sin(\pi x) + c_2 e^{-4\pi^2 t} \sin(2\pi x) + c_3 e^{-9\pi^2 t} \sin(3\pi x).$$

Figure 4.1 plots four time profiles showing how the bar cools down. \square

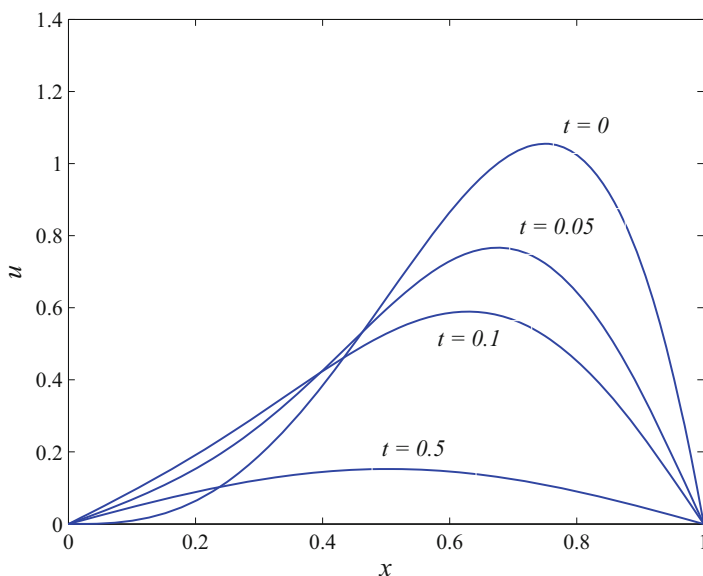

Figure 4.1 Temperature profiles in Example 4.4 at different times. As $t \rightarrow 0$ the temperature approaches the steady state solution, $u \equiv 0$

The separation of variables procedure described above can be imitated for a large number of problems. Next we illustrate the method for the wave equation, again with less detail.

Example 4.5

Recall that the wave equation models the small deflections of an elastic string fixed at both ends with an initial position and velocity given at time $t = 0$. We consider the problem

$$u_{tt} = c^2 u_{xx}, \quad 0 < x < l, \quad t > 0, \quad (4.17)$$

$$u(0, t) = 0, \quad u(l, t) = 0, \quad t > 0, \quad (4.18)$$

$$u(x, 0) = F(x), \quad u_t(x, 0) = G(x), \quad 0 < x < l, \quad (4.19)$$

where F and G are the initial position and velocity of the string. Assuming $u(x, t) = y(x)g(t)$ and substituting into the PDE (4.17) yields

$$y(x)g''(t) = c^2y''(x)g(t),$$

or, upon dividing by c^2yg ,

$$\frac{g''(t)}{c^2g(t)} = \frac{y''(x)}{y(x)}.$$

Setting each term equal to a constant $-\lambda$, we obtain the two ODEs

$$g''(t) + c^2\lambda g(t) = 0, \quad -y''(x) = \lambda y(x).$$

Next we substitute $u(x, t) = y(x)g(t)$ into the boundary conditions (4.18) to get

$$y(0)g(t) = 0, \quad y(l)g(t) = 0,$$

which gives $y(0) = 0$ and $y(l) = 0$. Therefore, we are led to the boundary value problem

$$-y''(x) = \lambda y(x), \quad 0 < x < l; \quad y(0) = 0, \quad y(l) = 0.$$

This boundary value problem is exactly the same as in the heat flow example above. The eigenvalues and eigenfunctions are (see (4.13–4.14))

$$\lambda_n = \frac{n^2\pi^2}{l^2}, \quad y_n(x) = \sin \frac{n\pi x}{l}, \quad n = 1, 2, \dots \quad (4.20)$$

Solving the ODE for $g(t)$,

$$g(t) = g_n(t) = C \sin \frac{n\pi ct}{l} + D \cos \frac{n\pi ct}{l}.$$

Therefore, we have constructed infinitely many product solutions of the PDE (4.17) having the form

$$u_n(x, t) = \left(c_n \sin \frac{n\pi ct}{l} + d_n \cos \frac{n\pi ct}{l} \right) \sin \frac{n\pi x}{l}, \quad n = 1, 2, \dots,$$

where we have replaced the arbitrary constants C and D by arbitrary constants c_n and d_n depending on n . These product solutions $u_n(x, t)$ represent modes of vibrations. The temporal part is periodic in time with period $2l/(nc)$; the spatial part has frequency $2l/n$. These product solutions also satisfy the boundary conditions (4.18) but do not satisfy the given initial conditions (4.19). So we form the linear combination

$$u(x, t) = \sum_{n=1}^{\infty} \left(c_n \sin \frac{n\pi ct}{l} + d_n \cos \frac{n\pi ct}{l} \right) \sin \frac{n\pi x}{l} \quad (4.21)$$

and select the constants c_n and d_n such that the initial conditions hold. Thus we require

$$u(x, 0) = F(x) = \sum_{n=1}^{\infty} d_n \sin \frac{n\pi x}{l}.$$

The right side is the Fourier sine series of the function $F(x)$ on the interval $(0, l)$. Therefore, the coefficients d_n are the Fourier coefficients given by

$$d_n = \frac{2}{l} \int_0^l F(x) \sin \frac{n\pi x}{l} dx, \quad n = 1, 2, \dots \quad (4.22)$$

To apply the other initial condition $u_t(x, 0) = G(x)$ we need to calculate the time derivative of $u(x, t)$. We obtain

$$u_t(x, t) = \sum_{n=1}^{\infty} \frac{nc\pi}{l} \left(c_n \cos \frac{n\pi ct}{l} - d_n \sin \frac{n\pi ct}{l} \right) \sin \frac{n\pi x}{l}.$$

Thus

$$u_t(x, 0) = G(x) = \sum_{n=1}^{\infty} \frac{nc\pi}{l} c_n \sin \frac{n\pi x}{l}.$$

Again, the right side is the Fourier sine series of G on $(0, l)$, so the coefficients of $\sin \frac{n\pi x}{l}$, which are $\frac{nc\pi}{l} c_n$, are the Fourier coefficients; that is,

$$\frac{nc\pi}{l} c_n = \frac{2}{l} \int_0^l G(x) \sin \frac{n\pi x}{l} dx, \quad n = 1, 2, \dots,$$

or

$$c_n = \frac{2}{nc\pi} \int_0^l G(x) \sin \frac{n\pi x}{l} dx, \quad n = 1, 2, \dots \quad (4.23)$$

Therefore, the solution of the initial boundary value problem is given by the infinite series (4.21) where the coefficients are given by (4.22) and (4.23).

Again, numerical calculations on a computer algebra system or a scientific calculator can be used to determine a few of the coefficients to obtain an approximate solution. However, for the wave equation several terms may be required for accuracy because, unlike the heat equation, there is no decaying exponential in the solution (4.21) to cause rapid decay of the terms in the series. \square

What we have described is the separation of variables method, and the procedure can be imitated on a large number of initial boundary value problems. Each problem leads to a boundary value problem for an ODE that has infinitely many solutions that form an orthogonal system. In the next section we focus attention on the ODE boundary value problem, called a Sturm–Liouville problem.

EXERCISES

1. Solve the heat flow problem with both boundaries insulated:

$$\begin{aligned}u_t &= k u_{xx}, \quad 0 < x < l, \quad t > 0, \\u_x(0, t) &= u_x(l, t) = 0, \quad t > 0, \\u(x, 0) &= 1 + 2 \cos \frac{3\pi x}{l}, \quad 0 \leq x \leq l.\end{aligned}$$

2. In the heat flow problem (4.1–4.3) take $k = 1$, $l = \pi$, and $f(x) = 0$ if $0 < x < \pi/2$, $f(x) = 1$ if $\pi/2 < x < \pi$. (a) Find an infinite series representation of the solution. (b) Use the first four terms in the series to obtain an approximate solution, and on the same set of coordinate axes sketch several time snapshots of the approximate temperature distribution in the bar in order to show how the bar cools down. (c) Estimate the error in these approximate distributions by considering the first neglected term. (d) What is $\lim_{t \rightarrow 0^+} u(\pi/2, t)$? Comment.
3. In the vibration problem (4.17–4.19) take $c = 1$, $l = \pi$, and $F(x) = x$ if $0 < x < \pi/2$, and $F(x) = \pi - x$ if $\pi/2 < x < \pi$, and take $G(x) \equiv 0$. (a) Find an infinite series representation of the solution. (b) Use the first four terms in the series to obtain an approximate solution, and on the same set of coordinate axes sketch several time snapshots of the wave. (c) Can you estimate the error in these approximate wave forms?
4. The initial boundary value problem for the damped wave equation,

$$\begin{aligned}u_{tt} + k u_t &= c^2 u_{xx}, \quad 0 < x < 1, \quad t > 0, \\u(0, t) &= 0, \quad u(1, t) = 0, \quad t > 0, \\u(x, 0) &= f(x), \quad u_t(x, 0) = 0, \quad 0 < x < 1,\end{aligned}$$

governs the displacement of a string immersed in a fluid. The string has unit length and is fixed at its ends; its initial displacement is f , and it has no initial velocity. The constant k is the damping constant and c is the wave speed. Use $k = 2$, $c = 1$ and apply the method of separation of variables to find the solution.

5. Consider heat flow in a rod of length l where the heat is lost across the lateral boundary is given by Newton's law of cooling. The model is

$$\begin{aligned}u_t &= k u_{xx} - h u, \quad 0 < x < l, \\u &= 0 \text{ at } x = 0, \quad x = l, \text{ for all } t > 0, \\u &= f(x) \text{ at } t = 0, \quad 0 \leq x \leq l,\end{aligned}$$

where $h > 0$ is the heat loss coefficient.

- a) Find the equilibrium temperature.
 b) Solve the problem.

4.2 Sturm–Liouville Problems

In this section we examine a broad class of initial boundary value problems of the form

$$u_t = (p(x)u_x)_x - q(x)u, \quad a < x < b, \quad t > 0, \quad (4.24)$$

$$\alpha_1 u(a, t) + \alpha_2 u_x(a, t) = 0, \quad (4.25)$$

$$\beta_1 u(b, t) + \beta_2 u_x(b, t) = 0, \quad (4.26)$$

$$u(x, 0) = f(x), \quad a < x < b. \quad (4.27)$$

The standard boundary conditions (i.e., Dirichlet, Neumann, and radiation) are included in (4.25–4.26) as special cases by choosing appropriate values of the constants.

When we assume a separable solution $u(x, t) = y(x)g(t)$, we obtain an ODE for $y = y(x)$ of the form

$$-(p(x)y')' + q(x)y = \lambda y, \quad a < x < b,$$

where λ is the separation constant (see Exercise 1). This type of ODE is called a **Sturm–Liouville differential equation**. The homogenous boundary conditions on the PDE transform into boundary conditions on y , namely,

$$\alpha_1 y(a) + \alpha_2 y'(a) = 0, \quad \beta_1 y(b) + \beta_2 y'(b) = 0.$$

Solving this important boundary value problem for the function $y(x)$ on a bounded interval $[a, b]$ is the subject of a large portion of this section and the basis for the separation of variables method. We state the problem in a general form.

Definition 4.6

Let p , p' , and q be continuous functions on the bounded interval $[a, b]$, and $p(x) \neq 0$ for all $x \in [a, b]$; assume further that $\alpha_1^2 + \alpha_2^2 \neq 0$ and $\beta_1^2 + \beta_2^2 \neq 0$. A **regular Sturm–Liouville problem (SLP)** is the problem of determining values of the constant λ for which the boundary value problem

$$-(p(x)y')' + q(x)y = \lambda y, \quad a < x < b, \quad (4.28)$$

$$\alpha_1 y(a) + \alpha_2 y'(a) = 0, \quad (4.29)$$

$$\beta_1 y(b) + \beta_2 y'(b) = 0. \quad (4.30)$$

has a nontrivial solution $y = y(x)$. By a solution we mean a function that is continuous and has a continuous derivative. We refer to these types of problems as (differential) **eigenvalue problems**. \square

If the interval $[a, b]$ is infinite, or if $p(x_0) = 0$ for some $x_0 \in [a, b]$ the SLP is called **singular**. In most problems, p is positive. Different types of boundary conditions also lead to singular problems. SLPs are named after J. C. F. Sturm and J. Liouville, who studied them in the mid 1830s. The condition that the constants α_1 and α_2 are not both zero, and the constants β_1 and β_2 are not both zero, guarantees that a boundary condition does not collapse at an endpoint.

As we saw in Example 4.1, a regular SLP need *not* have a nontrivial solution for some values of the constant λ . (Clearly, the zero function $y(x) \equiv 0$ is always a solution, but there is no interest in it). A value of λ for which there is a nontrivial solution of (4.28–4.30) is called an **eigenvalue**, and the corresponding nonzero solution is called an **eigenfunction**. Observe that any constant multiple of an eigenfunction is also an eigenfunction corresponding to the same eigenvalue; but it is not independent. The important fact about regular SLPs is that they have an infinite number of eigenvalues, and the corresponding eigenfunctions form a complete, orthogonal set, which makes orthogonal expansions possible. This is a *key idea* in applied mathematics, and it especially applies to the separation of variables method, which is the origin of the entire subject of Fourier series and orthogonal expansions.

Before proving some general facts about regular SLPs, we give an additional example with *mixed* boundary conditions. In this, and subsequent examples, we write y for $y(x)$, y' for $y'(x)$, etc., because the independent variable x is understood.

Example 4.7

Consider the regular SLP

$$\begin{aligned} -y'' &= \lambda y, & 0 < x < 1, \\ y'(0) &= 0, & y(1) = 0. \end{aligned}$$

We carry out a case argument to determine the possible eigenvalues. Exactly as in previous examples, we find that λ cannot be negative or zero. If $\lambda = \alpha^2 > 0$ then the general solution of the ODE is $y(x) = A \cos \alpha x + B \sin \alpha x$. Now, $y'(0) = \alpha B = 0$, giving $B = 0$; hence $y(x) = A \cos \alpha x$ and $y(1) = A \cos \alpha = 0$. There is no need to take $A = 0$, so we take $\cos \alpha = 0$, and thus α must be $\pi/2 + n\pi$, $n = 0, 1, 2, \dots$. Therefore the eigenvalues are

$$\lambda_n = \left(\frac{\pi}{2} + n\pi\right)^2 = \left(\frac{\pi}{2}(2n + 1)\right)^2, \quad n = 0, 1, 2, \dots$$

The corresponding eigenfunctions are

$$y_n(x) = \cos\left(\frac{\pi}{2}(2n+1)x\right), \quad n = 0, 1, 2, \dots$$

One can verify that the eigenfunctions form an orthogonal system on the interval $[0, 1]$. \square

We can always carry out a case argument as in the preceding example to determine the eigenvalues, their signs, and corresponding eigenfunctions. For many equations this can be tedious, and so it is advantageous to have some general results that allow us to reject or affirm certain cases immediately, without detailed calculation. This is discussed in the next section. For the present we state the central result regarding regular SLPs.

Theorem 4.8

For a regular Sturm–Liouville problem (4.28–4.30) the following hold:

1. There are infinitely many discrete eigenvalues λ_n , $n = 1, 2, \dots$, and the eigenvalues are real with $\lim_{n \rightarrow \infty} |\lambda_n| = +\infty$.
2. Eigenfunctions corresponding to distinct eigenvalues are orthogonal.
3. An eigenvalue can have only a single independent eigenfunction.
4. The set of all eigenfunctions $y_n(x)$ is complete in the sense that every square-integrable function f on $[a, b]$ can be expanded in a generalized Fourier series

$$f(x) = \sum_{n=1}^{\infty} c_n y_n(x), \quad c_n = \frac{(y_n, f)}{\|y_n\|^2},$$

which converges to f in the mean-square sense on $[a, b]$. \square

It is beyond our scope to prove the existence of the eigenvalues (see, for example, Birkhoff and Rota (1989)). But it is straightforward to demonstrate (2) and (3). First we introduce some notation that streamlines writing the formulas.

Notation. Let L denote the second-order differential operator defined by the left side of the Sturm–Liouville differential equation:

$$Ly = -(p(x)y')' + q(x)y, \quad a < x < b.$$

(It is common to write Ly and not $L(y)$.) So the SLP can be written simply as

$$Ly = \lambda y, \quad a < x < b, \tag{4.31}$$

$$\alpha_1 y(a) + \alpha_2 y'(a) = 0, \tag{4.32}$$

$$\beta_1 y(b) + \beta_2 y'(b) = 0. \tag{4.33}$$

We make liberal use of the inner product of two functions:

$$(y_1, y_2) = \int_a^b y_1(x)y_2(x)dx.$$

Finally, we introduce the **Wronskian** of two functions y_1, y_2 , defined by

$$W[y_1, y_2](x) = y_1(x)y_2'(x) - y_1'(x)y_2(x).$$

Notice the Wronskian is a function of x , and we usually write it simply as $W(x)$ if the two functions are understood. The reader may be familiar with this quantity from an elementary differential equations course.

The following lemma contains two extremely important identities that are used in the calculations.

Lemma 4.9

Let y_1 and y_2 be two C^1 functions on the interval $[a, b]$. Then,

$$y_2Ly_1 - y_1Ly_2 = \frac{d}{dx}[p(x)W(x)].$$

This identity is called **Lagrange's identity**. It follows that

$$(y_2, Ly_1) - (y_1, Ly_2) = [p(x)W(x)] \Big|_a^b = p(b)W(b) - p(a)W(a).$$

This is **Green's identity**. \square

The proof of Lagrange's identity is straightforward. Just take the derivative of $p(x)W(x)$ and verify, using the product rule, that it coincides with the left side:

$$\begin{aligned} \frac{d}{dx}[p(x)W(x)] &= \frac{d}{dx}[py_1y_2'] - \frac{d}{dx}[py_1'y_2] \\ &= (py_2')'y_1 + py_2'y_1' - (py_1')'y_2 - py_1'y_2' \\ &= (py_2')'y_1 - (py_1')'y_2 \\ &= -(py_1')'y_2 + qy_1y_2 + (py_2')'y_1 - qy_1y_2 \\ &= [- (py_1')' + qy_1]y_2 - [- (py_2')' + qy_2]y_1 = y_2Ly_1 - y_1Ly_2. \end{aligned}$$

To prove Green's identity integrate both sides of Lagrange's identity over $[a, b]$ and use the inner product notation. One can also prove Green's identity directly using integration by parts. \square

Now we demonstrate the proofs of various parts of Theorem 4.8.

Orthogonality of eigenfunctions. Let λ_1 and λ_2 be distinct eigenvalues of the SLP (4.31–4.33) with corresponding eigenfunctions $y_1(x)$ and $y_2(x)$. By Green’s identity,

$$\begin{aligned} (y_2, Ly_1) - (y_1, Ly_2) &= (y_2, \lambda y_1) - (y_1, \lambda y_2) \\ &= (\lambda_1 - \lambda_2)(y_1, y_2) \\ &= p(b)W(b) - p(a)W(a). \end{aligned}$$

Now we calculate $W(a)$ and $W(b)$ using the boundary conditions. Because both y_1 and y_2 satisfy the first boundary condition (4.32), we have

$$\begin{aligned} \alpha_1 y_1(a) + \alpha_2 y_1'(a) &= 0, \\ \alpha_1 y_2(a) + \alpha_2 y_2'(a) &= 0. \end{aligned}$$

These expressions can be regarded as a homogenous linear system in two unknowns α_1 and α_2 :

$$\begin{pmatrix} y_1(a) & y_1'(a) \\ y_2(a) & y_2'(a) \end{pmatrix} \begin{pmatrix} \alpha_1 \\ \alpha_2 \end{pmatrix} = \begin{pmatrix} 0 \\ 0 \end{pmatrix}.$$

By assumption, α_1 and α_2 are not both zero. Hence, the determinant of the coefficient matrix must be zero. That is, $y_1(a)y_2'(a) - y_1'(a)y_2(a) = W(a) = 0$. Similarly $W(b) = 0$. Therefore,

$$(\lambda_1 - \lambda_2)(y_1, y_2) = 0.$$

Because $\lambda_1 \neq \lambda_2$, we have $(y_1, y_2) = 0$, which means y_1 and y_2 are orthogonal. \square

The eigenvalues are real. Let λ be an eigenvalue with corresponding eigenfunction y . Then $Ly = \lambda y$ and y satisfies the boundary conditions (4.32–4.33). Taking the complex conjugate of the differential equation we get

$$L\bar{y} = \bar{\lambda}\bar{y}$$

and the complex conjugate \bar{y} satisfies the boundary conditions as well (with y replaced by \bar{y}). This means $\bar{\lambda}$, \bar{y} is also an eigenpair. As above, the Wronskian is zero at $x = a$ and $x = b$. Applying Green’s identity then gives

$$\begin{aligned} 0 &= (y, L\bar{y}) - (\bar{y}, Ly) = (y, \bar{\lambda}\bar{y}) - (\bar{y}, \lambda y) = (\bar{\lambda} - \lambda)(\bar{y}, y) \\ &= \int_a^b \bar{y}(x)y(x)dx = \int_a^b |y(x)|^2 dx. \end{aligned}$$

Because y is not identically zero, the last integral is positive. So $\bar{\lambda} = \lambda$. Because λ equals its complex conjugate, it must be real. \square

An eigenvalue λ has a unique eigenfunction, up to a constant multiple. Let y_1 and y_2 be two eigenfunctions associated with the eigenvalue λ . Then $Ly_1 = \lambda y_1$ and $Ly_2 = \lambda y_2$. By Lagrange's identity,

$$0 = y_2 Ly_1 - y_1 Ly_2 = \frac{d}{dx} [p(x)W(x)].$$

This means $p(x)W(x) = c = \text{constant}$. We can evaluate the constant by either of the boundary conditions. For example,

$$p(a)W(a) = c = 0$$

because, as we showed, the boundary condition forces $W(a) = 0$. Hence, $W(x) = y_1 y_2' - y_1' y_2 = 0$ for all x in $[a, b]$. This is the same as

$$\frac{d}{dx} \left(\frac{y_2}{y_1} \right) = 0, \quad (4.34)$$

or $y_1 = \text{constant} \cdot y_2$. Hence y_1 and y_2 are dependent functions. \square

The eigenfunctions are real. Let y be an eigenfunction corresponding to the real eigenvalue λ . If y is complex-valued, then $y = \phi(x) + i\psi(x)$, where ϕ and ψ are real-valued functions. By the linearity of L and the boundary conditions, it follows that both ϕ and ψ are eigenfunctions corresponding to λ . Then ϕ and ψ are linear dependent. So we can replace y with one of these real-valued eigenfunctions. \square

Example 4.10

(Periodic boundary conditions) Consider the simple boundary value problem

$$\begin{aligned} -y'' &= \lambda y, & -\pi < x < \pi, \\ y(-\pi) &= y(\pi), & y'(-\pi) &= y'(\pi). \end{aligned}$$

This is not a regular SLP because the boundary conditions, called *periodic boundary conditions*, are of a different type. Nevertheless, it is easy to check that the eigenvalues are $\lambda_n = n^2$, $n = 0, 1, 2, \dots$. Corresponding to $\lambda = 0$ is a *single* eigenfunction $y_0 = 1$, and corresponding to any $n > 0$ there are *two* linearly independent eigenfunctions, $\cos nx$ and $\sin nx$. This does not contradict the theorem. One can note that (4.34), required in the proof of uniqueness of an eigenfunction, cannot hold in this case. However, it remains true that $p(x)W(x) \Big|_{-\pi}^{\pi} = 0$. Hence the eigenvalues are real and the corresponding set of eigenfunctions form a complete orthogonal set. This set of eigenfunctions form the basis of the classical Fourier series

$$\frac{1}{2}a_0 + \sum_1^{\infty} a_n \cos nx + b_n \sin nx. \quad \square$$

Another important question concerns the *sign* of the eigenvalues. We can always carry out a case argument as in previous examples, but often an *energy argument* gives an answer more efficiently, as in the following example.

Example 4.11

(Energy argument) Consider the Sturm–Liouville differential equation

$$-y'' + q(x)y = \lambda y, \quad 0 < x < l,$$

with $q(x) > 0$ and mixed boundary conditions

$$y(0) = 0, \quad y'(l) = 0.$$

Let λ be an eigenvalue with corresponding eigenfunction $y = y(x)$. Multiply the differential equation by y and integrate to get

$$\int_0^l -yy'' dx + \int_0^l q(x)y^2 dx = \lambda \int_0^l y^2(x) dx.$$

This method gets its name from the expression

$$\int_0^l y^2(x) dx = \|y\|^2,$$

which is the *energy* of the function y . (See Section 3.3.) Now integrate the first integral by parts, pulling one derivative off y'' and putting it on y :

$$\int_0^l -yy'' dx = -y(x)y'(x) \Big|_0^l + \int_0^l (y')^2 dx.$$

Then

$$-y(x)y'(x) \Big|_0^l + \int_0^l (y')^2 dx + \int_0^l q(x)y^2 dx = \lambda \int_0^l y^2(x) dx.$$

The boundary conditions force the boundary term to be zero, and therefore

$$\int_0^l (y')^2 dx + \int_0^l q(x)y^2 dx = \lambda \int_0^l y^2(x) dx.$$

The left side is strictly positive, and the integral on the right is positive. Hence, $\lambda > 0$. This problem has only positive eigenvalues. \square

A similar argument using integration by parts can be made for the general Sturm–Liouville problem (4.28–4.30). The reader can show, as above, that if λ and y are an eigenvalue–eigenfunction pair, then

$$\lambda = \frac{\int_a^b (p(x)y'^2 + q(x)y^2) dx - p(x)y(x)y'(x) \Big|_a^b}{\|y\|^2}. \quad (4.35)$$

This expression for the eigenvalue λ is called the **Rayleigh quotient**. The boundary term in the numerator involving the Wronskian may be simplified by the SLP boundary conditions (4.29–4.30).

Example 4.12

Consider the SLP

$$\begin{aligned} -y'' &= \lambda y, & 0 < x < 1, \\ y(0) &= 0, & y(1) + \beta y_1'(1) = 0, & \beta > 0. \end{aligned}$$

Here $p(x) = 1$ and $q(x) = 0$. Therefore, if λ and y are an eigenpair, then the Rayleigh quotient gives

$$\lambda = \frac{\int_0^1 y'^2 dx - y(x)y'(x) \Big|_0^1}{\|y\|^2}.$$

But

$$-y(1)y'(1) + y(0)y'(0) = \beta y_1'(1)^2 > 0.$$

Hence, the eigenvalues are positive. \square

Next we solve a problem with a radiation-type boundary condition.

Example 4.13

Consider the diffusion problem

$$u_t = k u_{xx}, \quad 0 < x < 1, \quad t > 0, \quad (4.36)$$

$$u(0, t) = 0, \quad u(1, t) + u_x(1, t) = 0, \quad t > 0, \quad (4.37)$$

$$u(x, 0) = f(x), \quad 0 < x < 1, \quad (4.38)$$

where the left end is fixed and the right end satisfies a radiation-type condition; note that if $u > 0$ at $x = 1$ then $u_x < 0$ at $x = 1$, so heat is radiating out of the bar. We assume $u(x, t) = y(x)g(t)$ and substitute into the PDE to obtain

$$\frac{g'(t)}{kg(t)} = \frac{y''(x)}{y(x)} = -\lambda,$$

where $-\lambda$ is the separation constant. This gives the two ODEs

$$g'(t) = -\lambda kg(t), \quad -y''(x) = \lambda y(x).$$

Substituting the product $u = yg$ into the boundary conditions gives

$$y(0)g(t) = 0, \quad y(1)g(t) + y'(1)g(t) = 0.$$

Since $g(t) \neq 0$, we are forced to take $y(0) = 0$ and $y(1) + y'(1) = 0$, and we are left with the Sturm–Liouville problem

$$-y'' = \lambda y, \quad 0 < x < 1; \quad y(0) = 0, \quad y(1) + y'(1) = 0.$$

We know from Example 4.12 that the eigenvalues are positive. For $\lambda > 0$ the solution to the ODE is $y(x) = A \cos \sqrt{\lambda}x + B \sin \sqrt{\lambda}x$. The boundary condition $y(0) = 0$ forces $A = 0$, and the boundary condition $y(1) + y'(1) = 0$ forces the condition

$$\sin \sqrt{\lambda} + \sqrt{\lambda} \cos \sqrt{\lambda} = 0,$$

or

$$\sqrt{\lambda} = -\tan \sqrt{\lambda}.$$

This equation, where the variable λ is tied up in a trigonometric function, cannot be solved analytically. But plots of the functions $\sqrt{\lambda}$ and $-\tan \sqrt{\lambda}$ versus λ (see Figure 4.2) show that the equation has infinitely many positive solutions $\lambda_1, \lambda_2, \dots$, represented by the intersection points of the two graphs. Numerically, we find $\lambda_1 = 4.115858$, $\lambda_2 = 24.13934$, $\lambda_3 = 63.65911$.

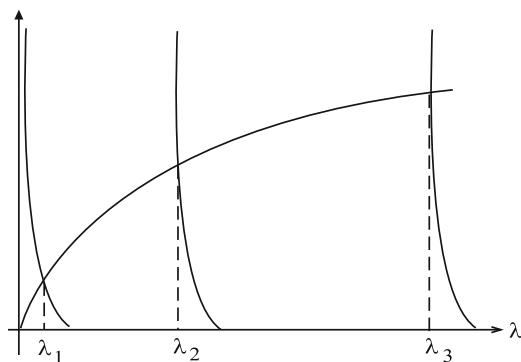

Figure 4.2 Graphical representation of the first three eigenvalues of the SLP at the intersection of $y = -\tan(\sqrt{\lambda})$ and $y = \sqrt{\lambda}$

These values λ_n are the eigenvalues for the Sturm–Liouville problem, and the corresponding eigenfunctions are

$$y_n = \sin \sqrt{\lambda_n}x, \quad n = 1, 2, \dots$$

By the Sturm–Liouville theorem we know that the eigenfunctions $y_n(x)$ are orthogonal on $0 < x < 1$, which means that

$$\int_0^1 \sin \sqrt{\lambda_n}x \sin \sqrt{\lambda_m}x dx = 0 \quad \text{for } m \neq n.$$

The solution to the time equation is

$$g(t) = ce^{-\lambda kt},$$

and since there are infinitely many values of λ , we have infinitely many such solutions,

$$g_n(t) = c_n e^{-\lambda_n kt}.$$

Summarizing, we have obtained infinitely many product solutions of the form

$$c_n e^{-\lambda_n kt} \sin \sqrt{\lambda_n} x, \quad n = 1, 2, \dots$$

These functions will solve the PDE (4.36) and the boundary conditions (4.37). We superimpose these to form

$$u(x, t) = \sum_{n=1}^{\infty} c_n e^{-\lambda_n kt} \sin \sqrt{\lambda_n} x, \quad (4.39)$$

and we select the coefficients c_n such that u will satisfy the initial condition (4.38). We have

$$u(x, 0) = f(x) = \sum_{n=1}^{\infty} c_n \sin \sqrt{\lambda_n} x.$$

This equation is an expansion of the function $f(x)$ in terms of the eigenfunctions $y_n(x)$. We know from Chapter 3 that the coefficients c_n are given by the formula

$$c_n = \frac{1}{\|y_n\|^2} \int_0^1 f(x) \sin \sqrt{\lambda_n} x \, dx, \quad n = 1, 2, \dots,$$

or

$$c_n = \frac{1}{\int_0^1 \sin^2 \sqrt{\lambda_n} x \, dx} \int_0^1 f(x) \sin \sqrt{\lambda_n} x \, dx, \quad n = 1, 2, \dots \quad (4.40)$$

Consequently, the solution of (4.36–4.38) is given by (4.39), where the coefficients c_n are given by (4.40).

Using MATLAB to calculate a three-term approximation to the solution in the case $k = 0.1$ with initial temperature $f(x) = 10x(1 - x)$, we find the coefficients c_1, c_2, c_3 are given by

$$c_1 = 2.13285, \quad c_2 = 1.040488, \quad c_3 = -0.219788.$$

Therefore, a three-term approximate solution is

$$\begin{aligned} u(x, t) &\approx 2.13285 e^{-4.115858t} \sin \sqrt{4.115858} x \\ &+ 1.040488 e^{-24.13934t} \sin \sqrt{24.13934} x \\ &- 0.219788 e^{-63.65911t} \sin \sqrt{63.65911} x. \quad \square \end{aligned}$$

We end this section with some summarizing comments and terminology. For the regular Sturm–Liouville problem (4.31–4.33), Green’s identity

$$(y_1, Ly_2) - (y_2, Ly_1) = p \left[y_1 y_2' - y_1' y_2 \right] \Big|_a^b$$

was an essential tool in obtaining results concerning eigenvalues, orthogonality of eigenfunctions, and so on. As we showed, the boundary conditions have the property that for any two functions y_1, y_2 satisfying the same set of boundary conditions (4.32–4.33),

$$p \left[y_1 y_2' - y_1' y_2 \right] \Big|_a^b = 0. \quad (4.41)$$

In this case we say the boundary conditions are **symmetric**. Whenever we have symmetric boundary conditions for a regular SLP, it is clear that

$$(y_1, Ly_2) = (y_2, Ly_1).$$

When this property holds with corresponding symmetric boundary conditions, we say that the differential operator L is symmetric, or **self-adjoint**.

Example 4.14

We showed that the differential operator $Ly = -y''$, $a < x < b$, with periodic boundary conditions is self-adjoint. However, one can check (an exercise) that the operator $L = -(p(x)y')'$, $a < x < b$ is not self-adjoint with periodic boundary conditions unless $p(a) = p(b)$. \square

EXERCISES

1. Show that substitution of $u(x, t) = g(t)y(x)$ into the PDE

$$u_t = (p(x)u_x)_x - q(x)u, \quad a < x < b, \quad t > 0,$$

leads to the pair of differential equations

$$g'(t) = -\lambda g(t), \quad -(p(x)y')' + q(x)y = \lambda y,$$

where λ is some constant.

2. Show that the SLP

$$\begin{aligned} -y''(x) &= \lambda y(x), & 0 < x < l, \\ y'(0) &= 0, & y(l) = 0, \end{aligned}$$

with mixed Dirichlet and Neumann boundary conditions has eigenvalues

$$\lambda_n = \left(\frac{(1 + 2n)\pi}{2l} \right)^2$$

and corresponding eigenfunctions

$$y_n(x) = \cos \frac{(1 + 2n)\pi x}{2l}$$

for $n = 0, 1, 2, \dots$

3. Consider the SLP

$$-y'' = \lambda y, \quad 0 < x < 1; \quad y(0) + y'(0) = 0, \quad y(1) = 0.$$

Is $\lambda = 0$ an eigenvalue? Are there any negative eigenvalues? Show that there are infinitely many positive eigenvalues by finding an equation whose roots are those eigenvalues, and show graphically that there are infinitely many roots.

4. Show that the SLP

$$-y'' = \lambda y, \quad 0 < x < 2; \quad y(0) + 2y'(0) = 0, \quad 3y(2) + 2y'(2) = 0,$$

has exactly one negative eigenvalue. Is zero an eigenvalue? How many positive eigenvalues are there?

5. For the SLP

$$-y'' = \lambda y, \quad 0 < x < l; \quad y(0) - ay'(0) = 0, \quad y(l) + by'(l) = 0,$$

show that $\lambda = 0$ is an eigenvalue if and only if $a + b = -l$.

6. What can you say about the sign of the eigenvalues for the SLP

$$-y'' + xy = -\lambda y, \quad 0 < x < 1, \quad y(0) = y(1) = 0.$$

Use a computer algebra package to find the eigenvalues and eigenfunctions. Hint: Look up *Airy's differential equation*.

7. Consider the regular SLP

$$\begin{aligned} -y'' + q(x)y &= \lambda y, \quad 0 < x < l, \\ y(0) &= y(l) = 0, \end{aligned}$$

where $q(x) > 0$ on $[0, l]$. Show that if λ and y are an eigenvalue and eigenfunction, respectively, then

$$\lambda = \frac{\int_0^l (y'^2 + qy^2) dx}{\|y\|^2}.$$

Is $\lambda > 0$? Can $y(x) = \text{constant}$ be an eigenfunction?

8. Does the boundary value problem

$$\begin{aligned} -y'' &= \lambda y, & a < x < b, \\ y(a) &= y(b), & y'(b) = 2y'(a), \end{aligned}$$

have symmetric boundary conditions? Is it self-adjoint?

9. Find the eigenvalues and eigenfunctions for the following problem with *periodic* boundary conditions:

$$\begin{aligned} -y''(x) &= \lambda y(x), & 0 < x < l, \\ y(0) &= y(l), & y'(0) = y'(l). \end{aligned}$$

10. Consider a large, circular, tubular ring of circumference $2l$ that contains a chemical of concentration $c(x, t)$ dissolved in water. Let x be the arc-length parameter with $0 < x < 2l$. See Figure 4.3. If the concentration

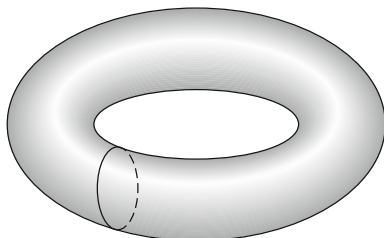

Figure 4.3 Circular ring

of the chemical is initially given by $f(x)$, then $c(x, t)$ satisfies the initial boundary value problem

$$\begin{aligned} c_t &= Dc_{xx}, & 0 < x < 2l, & t > 0, \\ c(0, t) &= c(2l, t), & c_x(0, t) &= c_x(2l, t), & t > 0, \\ c(x, 0) &= f(x), & 0 < x < 2l. \end{aligned}$$

These boundary conditions are called **periodic boundary conditions**, and D is the diffusion constant. Apply the separation of variables method and show that the associated Sturm–Liouville problem has eigenvalues $\lambda_n = (n\pi/l)^2$ for $n = 0, 1, 2, \dots$ and eigenfunctions $y_0(x) = 1, y_n(x) = A_n \cos(n\pi x/l) + B_n \sin(n\pi x/l)$ for $n = 1, 2, \dots$. Show that the concentration is given by

$$c(x, t) = \frac{A_0}{2} + \sum_{n=1}^{\infty} (A_n \cos(n\pi x/l) + B_n \sin(n\pi x/l)) e^{-n^2 \pi^2 D t / l^2}$$

and find formulas for the A_n and B_n .

11. Find eigenvalues and eigenfunctions for the singular problem

$$-y'' + x^2y = \lambda y, \quad x \in \mathbb{R}; \quad y \in L^2(\mathbb{R}).$$

Use a computer algebra system if needed.

12. Find an infinite series representation for the solution to the wave problem

$$\begin{aligned} u_{tt} &= c^2 u_{xx}, \quad 0 < x < l, \quad t > 0, \\ u(0, t) &= u_x(l, t) = 0, \quad t > 0, \\ u(x, 0) &= f(x), \quad u_t(x, 0) = 0, \quad 0 < x < l. \end{aligned}$$

Interpret this problem in the context of waves on a string.

13. Find an infinite-series representation for the solution to the heat absorption–radiation problem

$$\begin{aligned} u_t &= u_{xx}, \quad 0 < x < 1, \quad t > 0, \\ u_x(0, t) - a_0 u(0, t) &= 0, \quad u_x(1, t) + a_1 u(1, t) = 0, \quad t > 0, \\ u(x, 0) &= f(x), \quad 0 < x < 1, \end{aligned}$$

where $a_0 < 0$, $a_1 > 0$, and $a_0 + a_1 > -a_0 a_1$. State why there is radiation at $x = 1$, absorption at $x = 0$, and the radiation greatly exceeds the absorption. Choose $a_0 = -0.25$ and $a_1 = 4$ and find the first four eigenvalues; if $f(x) = x(1 - x)$, find an approximate solution to the problem and plot either the approximate solution surface or time snapshots.

4.3 Generalization and Singular Problems

A straightforward generalization of a regular Sturm–Liouville problem is the SLP

$$L_w y = -(p(x)y')' + q(x)y = \lambda r(x)y, \quad a < x < b, \quad (4.42)$$

$$\alpha_1 y(a) + \alpha_2 y'(a) = 0, \quad (4.43)$$

$$\beta_1 y(b) + \beta_2 y'(b) = 0, \quad (4.44)$$

which now includes a positive, continuous **weight function** $r = r(x)$ on the right side of the differential equation. Here, the same conditions on p , q , and the boundary conditions hold as before. Many physical processes lead to this type of equation after separating variables.

The Sturm–Liouville theorem holds exactly as before, but with a different definition of orthogonality. We define the **weighted inner product** of two functions by

$$(y_1, y_2)_w = \int_a^b y_1(x)y_2(x)r(x)dx.$$

This leads to the **weighted norm**

$$\|y\|_w = \sqrt{(y, y)_w}.$$

The conclusions of Theorem 4.8 are the same but with the fact that the eigenfunctions are orthogonal with respect to the weighted inner product. Moreover, the eigenfunctions $y_n(x)$, $n = 1, 2, 3, \dots$ form a complete orthogonal set of functions on $[a, b]$; that is, if f is square integrable in the weighted norm, then

$$f(x) = \sum_{n=1}^{\infty} c_n y_n(x),$$

in the mean square sense, where

$$c_n = \frac{(f, y_n)_w}{\|y_n\|_w^2}, \quad n = 1, 2, 3, \dots$$

Example 4.15

Consider the eigenvalue problem

$$\begin{aligned} -y'' + y' &= \lambda y, & 0 < x < 1, \\ y(0) &= y(1) = 0. \end{aligned}$$

As it stands, this problem is not in self-adjoint form, so we cannot apply Theorem 4.8 directly. However, if we multiply by the integrating factor e^{-x} , the equation becomes

$$-(e^{-x}y')' = \lambda e^{-x}y,$$

which is of regular Sturm–Liouville type, with weight function $r(x) = e^{-x}$. One can use an energy argument, or case argument, to easily show that the eigenvalues are positive and are given by

$$\lambda_n = \frac{1}{4} + n^2\pi^2, \quad n = 1, 2, \dots$$

with eigenfunctions

$$y_n(x) = e^{x/2} \sin n\pi x, \quad n = 1, 2, \dots$$

The eigenfunctions are orthogonal with respect to weight function e^{-x} :

$$\begin{aligned} (y_n, y_m)_w &= \int_0^1 e^{x/2} \sin n\pi x \cdot e^{x/2} \sin m\pi x e^{-x} dx \\ &= \int_0^1 \sin n\pi x \sin m\pi x dx = 0. \end{aligned}$$

Therefore, if f is square integrable, then we can write

$$f(x) = \sum_{n=1}^{\infty} c_n e^{-x} \sin n\pi x,$$

in the mean square sense, where c_n

$$c_n = \frac{(f, y_n)_w}{(y_n, y_n)_w}, \quad n = 1, 2, 3, \dots \quad \square$$

Remark 4.16

A differential equation of the form

$$y'' + a(x)y' + b(x)y = \lambda y$$

can be put into self-adjoint form by multiplying by the integrating factor

$$\mu(x) = e^{\int_a^x a(\xi) d\xi}.$$

Then, note $\mu'(x) = \mu(x)a(x)$, and the differential equation becomes

$$(\mu(x)y')' + \mu(x)b(x)y = \lambda\mu(x)y,$$

or

$$(\mu(x)y')' + q(x)y = \lambda\mu(x)y, \quad q(x) = \mu(x)b(x). \quad \square$$

Singular Problems

Singular problems occur for the SLP

$$L_w y = -(p(x)y')' + q(x)y = \lambda r(x)y, \quad a < x < b, \quad (4.45)$$

$$\alpha_1 y(a) + \alpha_2 y'(a) = 0, \quad (4.46)$$

$$\beta_1 y(b) + \beta_2 y'(b) = 0, \quad (4.47)$$

when $p(x_0) = 0$ at some point x_0 in the interval $[a, b]$. Here we assume either $p(a) = 0$ or $p(b) = 0$.⁸ In the case $p(a) = 0$ we generally replace the boundary condition at $x = a$ by the condition that $y(a)$ is bounded.

⁸ If $p(x) = 0$ at an interior point in the interval, then that point is called a *turning point*. Turning points are examined in more advanced treatments.

Example 4.17

The singular SLP

$$\begin{aligned} -(xy')' &= \lambda xy, \quad 0 < x < R, \\ y(0) &\text{ bounded, } y(R) = 0 \end{aligned}$$

occurs in the initial BVP for the heat equation in a circular disk of radius R . This is discussed in detail in Section 4.6. The differential equation is called **Bessel's equation**. We show here that this problem is self-adjoint. Denoting $Ly = -(xy')'$ and letting y_1 and y_2 be two functions that satisfy the boundary conditions, by Green's identity we get

$$\begin{aligned} (y_1, Ly_2) - (y_2, Ly_1) &= x \left[y_1(x)y_2'(x) - y_1'(x)y_2(x) \right]_0^R \\ &= -(0) \left[y_1(0)y_2'(0) - y_1'(0)y_2(0) \right] = 0. \end{aligned}$$

So, L is self-adjoint. Therefore the results of the Sturm–Liouville theorem hold: there are infinitely many discrete eigenvalues and the eigenfunctions are orthogonal with weight function $r(x) = x$. Refer to Section 4.6. \square

Example 4.18

Consider the singular SLP

$$\begin{aligned} -y'' &= \lambda y, \quad x > 0, \\ y(0) &= 0, \quad y(x) \text{ bounded.} \end{aligned}$$

The problem is singular because the interval is infinite. It is clear that $\lambda > 0$ because negative λ gives exponential solutions which cannot satisfy the boundary conditions; zero cannot be an eigenvalue for the same reason. The general solution is $y(x) = A \sin \sqrt{\lambda}x + B \cos \sqrt{\lambda}x$. The left boundary condition $y(0) = 0$ forces $B = 0$. We are left with $y(x) = A \sin \sqrt{\lambda}x$. Therefore, the bounded solutions, or eigenfunctions, are

$$y_\lambda(x) = \sin \sqrt{\lambda}x, \quad \lambda > 0,$$

and the eigenvalues are *all* positive values of λ ; this is a *continuous* set of eigenvalues, rather than discrete. In this case there is no classical orthogonality property on $(0, \infty)$. However, there is a continuous version of a Fourier expansion. If f is piecewise continuous on $x \geq 0$, and if f is absolutely integrable, or

$$\int_0^\infty |f(x)| dx < \infty,$$

then we can represent f by a continuous version of a Fourier sine series, namely,

$$f(x) = \frac{2}{\pi} \int_0^{\infty} F(\alpha) \sin \alpha x \, d\alpha, \quad (4.48)$$

where we have let $\alpha = \sqrt{\lambda}$; it can be shown that the coefficient function $F(\alpha)$ is given by

$$F(\alpha) = \int_0^{\infty} f(x) \sin \alpha x \, dx. \quad (4.49)$$

The function $F(\alpha)$ in (4.49) is called the **Fourier sine transform** of f and is commonly denoted by $\mathcal{S}(f)$. It acts in a similar way to other transforms where derivative operations are turned into multiplication operations. Fourier sine transforms are convenient for solving differential equations on $0 \leq x < \infty$. Other sources contain tables of sine (and cosine) transforms and their inverses, similar to those for Laplace transforms. We refer readers to Churchill (1969, 1972) or Farlow (1993), for example. \square

EXERCISES

1. Is the partial differential equation

$$\left(x^2 u_x\right)_x + x^2 u_{tt} = 0$$

separable? Is

$$u_{xx} + (x + y)^2 u_{yy} = 0$$

separable?

2. Use an energy argument to prove that the SLP

$$-\left(e^{-x} y'\right)' = \lambda e^{-x} y, \quad 0 < x < 1, \quad y(0) = y(1) = 0$$

has only positive eigenvalues.

3. Consider the SLP

$$-\left(xy'\right)' = \lambda \frac{1}{x} y, \quad 1 < x < b, \quad y(1) = y(b) = 0.$$

Find the eigenvalues and eigenfunctions, and write down the Fourier expansion for a given function $f(x)$ on the interval.

4. Consider the SLP

$$-\left(x^2 y'\right)' = \lambda y, \quad 1 < x < \pi, \quad y(1) = y(\pi) = 0.$$

Use an energy argument to show that any eigenvalue must be nonnegative. Find the eigenvalues and eigenfunctions.

5. Show that the differential operator

$$Ly = a(x)y'' + b(x)y' + c(x)y$$

can be written

$$\frac{a(x)}{p(x)} \left[\left(p(x)y' \right)' + \frac{c(x)p(x)}{a(x)}y \right],$$

and therefore the eigenvalue problem $Ly = \lambda y$ can be written

$$-\left(p(x)y' \right)' + q(x)y = \lambda r(x)y$$

for appropriately defined functions p , q , and r .

6. Let L be the differential operator defined by $Ly = a(x)y'' + b(x)y' + c(x)y$, $0 < x < 1$. Find an operator L^* for which

$$\left(y_1, Ly_2 \right) = \left(y_2, L^*y_1 \right) + B(x) \Big|_0^1,$$

where $B(x) \Big|_0^1$ represents boundary terms. The operator L^* is called the *formal adjoint* of L . Hint: Write out the inner product (y_1, Ly_2) and integrate by parts twice to remove the derivatives on y_2 and put them on y_1 .

7. Consider the initial BVP for the wave equation on $0 < x < l$ with variable sound speed $c(x)$:

$$\begin{aligned} u_{tt} &= c(x)^2 u_{xx}, & 0 < x < l, & t > 0, \\ u(0, t) &= u(l, t) = 0, & t > 0, \\ u(x, 0) &= f(x), & u_t(x, 0) &= 0, & 0 \leq x \leq l. \end{aligned}$$

Find the Sturm–Liouville problem associated this BVP. What is the weight function in the orthogonality relation?

8. (Parameter identification) This problem deals with determining the unknown density of a nonhomogeneous vibrating string by observing one fundamental frequency and the corresponding mode of vibration. Consider a stretched string of unit length and unit tension that is fastened at both ends. The displacement is governed by (see Section 1.5)

$$\rho(x)u_{tt} = u_{xx}, \quad 0 < x < 1, \quad t > 0, \tag{4.50}$$

$$u(0, t) = u(1, t) = 0, \quad t > 0, \tag{4.51}$$

where $\rho(x)$ is the unknown density. If we assume a solution of the form $u(x, t) = y(x)g(t)$, then we obtain a Sturm–Liouville problem

$$-y'' = \lambda \rho(x)y, \quad 0 < x < 1; \quad y(0) = y(1) = 0.$$

Suppose we observe (say, using a strobe light) a fundamental frequency $\lambda = \lambda_f$ and the associated mode (eigenfunction) $y = y_f(x)$. Show that the unknown density must satisfy the integral equation

$$\int_0^1 (1-x)y_f(x)\rho(x)dx = \frac{y_f'(0)}{\lambda_f}.$$

Hint: Integrate the ODE from $x = 0$ to $x = s$ and then from $s = 0$ to $s = 1$. Determine the density if it is a constant.

9. (Parameter identification) Consider heat flow in a rod of length π and unit diffusivity whose ends are held at constant zero temperature and whose initial temperature is zero degrees. Suppose further that there is an external heat source $f(x)$ supplying heat to the bar. Address the question of recovering the heat source $f(x)$ from a temporal measurement of the temperature $U(t)$ made at the midpoint of the rod. Proceed by formulating the appropriate equations and show that $f(x)$ must be the solution to the integral equation

$$U(t) = \int_0^t \int_0^\pi g(\xi, t - \tau)f(\xi) d\xi d\tau,$$

where

$$g(\xi, t) = \frac{2}{\pi} \sum_{n=1}^{\infty} e^{-n^2 t} \sin \frac{n\pi}{2} \sin n\xi.$$

Show that for any positive integer m , the pair

$$u(x, t) = m^{-3/2} (1 - e^{-m^2 t}) \sin mx, \quad f(x) = \sqrt{m} \sin mx$$

satisfies the model equations you proposed. Show that for m large, $u(x, t)$ is (uniformly) small, yet $\max |f(x)|$ is large, and thus state why small errors in the measurement $U(t)$ may lead to large differences in $f(x)$. (This means that recovery of f by solving the integral equation above may be unstable and therefore difficult.).

4.4 Laplace's Equation

In Section 1.7 we introduced Laplace's equation, which is given in two and three dimensions by

$$u_{xx} + u_{yy} = 0, \quad u_{xx} + u_{yy} + u_{zz} = 0,$$

respectively. Applications of Laplace's equation are far-reaching, from steady-state heat flow, electrostatics, potential flow of a fluid, deflections of a membrane, to complex analysis. Solutions of Laplace's equation are called **harmonic**, or **potential functions**, referring, for example, to the potential of an electric field. Laplace's equation itself is sometimes called the potential equation.

The separation of variables method can easily be applied to solve Laplace's equation on rectangles in two dimensions, just exactly as the heat equation and wave equation were solved. Exercises at the end of this section provide examples. In Chapter 2, using Fourier transforms, we solved Laplace's equation in a half space $y > 0$. Presently, we extend the eigenfunctions method to circular domains, wedges, and annuli. Later, we develop some general properties of harmonic functions in both two and three dimensions.

Temperatures in a Disk

Suppose we know the temperature on the boundary of a circular, laminar disk of radius R . The goal is to find the equilibrium temperatures inside the disk. Separation of variables works in a straightforward way and leads to a particularly nice integral formula for the solution.

Because the region of interest is a disk, we guess that polar coordinates are more appropriate than rectangular coordinates, so we formulate the steady-state heat flow problem in polar coordinates r and θ , where

$$x = r \cos \theta, \quad y = r \sin \theta.$$

Then a circular disk of radius R can be represented simply as $0 \leq r \leq R$, $0 \leq \theta \leq 2\pi$. The unknown temperature inside the disk is $u = u(r, \theta)$, and the prescribed temperature on the boundary of the plate is $u(R, \theta) = f(\theta)$, where f is a given function. We know from prior discussions (Section 1.8) that u must satisfy Laplace's equation $\Delta u = 0$ inside the disk. Therefore, upon representing the Laplacian Δ in polar coordinates (see Section 1.8), we are faced with the following boundary value problem for $u(r, \theta)$:

$$u_{rr} + \frac{1}{r}u_r + \frac{1}{r^2}u_{\theta\theta} = 0, \quad 0 < r < R, \quad 0 \leq \theta \leq 2\pi, \quad (4.52)$$

$$u(R, \theta) = f(\theta), \quad 0 \leq \theta \leq 2\pi. \quad (4.53)$$

Implicit are periodic boundary conditions

$$u(r, 0) = u(r, 2\pi), \quad u_\theta(r, 0) = u_\theta(r, 2\pi). \quad (4.54)$$

The separation of variables method works the same way as in rectangular coordinates. We assume a product solution $u(r, \theta) = y(r)g(\theta)$ and substitute into the PDE to obtain

$$y''(r)g(\theta) + \frac{1}{r}y'(r)g(\theta) + \frac{1}{r^2}y(r)g''(\theta) = 0.$$

This can be written

$$-\frac{r^2y''(r) + ry'(r)}{y(r)} = \frac{g''(\theta)}{g(\theta)} = -\lambda,$$

where $-\lambda$ is the separation constant. Therefore, we obtain two ordinary differential equations for y and g , namely,

$$r^2y''(r) + ry'(r) = \lambda y(r), \quad g''(\theta) = -\lambda g(\theta).$$

The *periodic boundary conditions* force $g(0) = g(2\pi)$ and $g'(0) = g'(2\pi)$. Therefore, we have the following self-adjoint SLP problem for $g(\theta)$:

$$g''(\theta) = -\lambda g(\theta); \quad g(0) = g(2\pi), \quad g'(0) = g'(2\pi). \quad (4.55)$$

First, it is clear that $\lambda = 0$ is an eigenvalue with corresponding eigenfunction $g_0(\theta) = 1$. Moreover, there are no negative eigenvalues; if λ is negative, then the ODE has exponential solutions, and exponential solutions cannot satisfy periodicity conditions. (Or, one could apply an energy argument to show nonnegativity.) Therefore, let us assume $\lambda = p^2 > 0$. The differential equation for g has general solution

$$g(\theta) = a \cos p\theta + b \sin p\theta.$$

The periodic boundary conditions force

$$\begin{aligned} (\cos 2\pi p - 1)a + (\sin 2\pi p)b &= 0, \\ (\sin 2\pi p)a + (1 - \cos 2\pi p)b &= 0. \end{aligned}$$

This is a system of two linear homogeneous algebraic equations for the constants a and b . From matrix algebra, we know that it has a nontrivial solution if the determinant of the coefficients is zero, i.e.,

$$(\cos 2\pi p - 1)(1 - \cos 2\pi p) - \sin^2 2\pi p = 0,$$

or, simplifying,

$$\cos 2\pi p = 1.$$

This means that $p = \sqrt{\lambda}$ must be a positive integer, that is,

$$\lambda = \lambda_n = n^2, \quad n = 1, 2, \dots$$

Along with $\lambda_0 = 0$, these are the eigenvalues of the problem (4.55). The eigenfunctions are

$$g_0(\theta) = 1, \quad g_n(\theta) = a_n \cos n\theta + b_n \sin n\theta, \quad n = 1, 2, \dots$$

Next we solve the y -equation. Of course, we want bounded solutions. For $\lambda = 0$ the only bounded solution is $y_0(r) = 1$ (the other independent solution in this case is $\ln r$, which is unbounded). For $\lambda = n^2$ the equation is

$$r^2 y''(r) + r y'(r) - n^2 y(r) = 0,$$

which is a *Cauchy–Euler equation* (see the Appendix) with general solution

$$y_n(r) = c_n r^{-n} + d_n r^n. \quad (4.56)$$

We can set $c_n = 0$ because we want bounded solutions on $0 \leq r \leq R$. Thus, setting $d_n = 1$ for all n , we have

$$y_n(r) = r^n, \quad n = 1, 2, \dots$$

In summary, we constructed solutions of the given boundary value problem of the form $u_0(r, \theta) = \text{constant} = a_0/2$, $u = u_n(r, \theta) = r^n(a_n \cos n\theta + b_n \sin n\theta)$, $n = 1, 2, \dots$. To satisfy the boundary condition at $r = R$ we form the linear combination

$$u(r, \theta) = \frac{a_0}{2} + \sum_{n=1}^{\infty} r^n (a_n \cos n\theta + b_n \sin n\theta). \quad (4.57)$$

The boundary condition $u(R, \theta) = f(\theta)$ then yields

$$f(\theta) = \frac{a_0}{2} + \sum_{n=1}^{\infty} R^n (a_n \cos n\theta + b_n \sin n\theta),$$

which is the full-range Fourier series for $f(\theta)$ (see Section 3.3). Therefore, the coefficients are given by

$$a_n = \frac{1}{\pi R^n} \int_0^{2\pi} f(\theta) \cos n\theta \, d\theta, \quad n = 0, 1, 2, \dots, \quad (4.58)$$

$$b_n = \frac{1}{\pi R^n} \int_0^{2\pi} f(\theta) \sin n\theta \, d\theta, \quad n = 1, 2, \dots \quad (4.59)$$

Hence, the solution to the BVP (4.52–4.54) is given by (4.57) with the coefficients given by (4.58–4.59).

As it turns out, this infinite series solution can be cleverly manipulated to obtain a simple formula, called Poisson's integral formula, for the solution. Let us substitute the coefficients given in formulas (4.58) and (4.59) (after changing

the dummy integration variable from θ to ϕ) into the solution formula (4.57) to obtain

$$\begin{aligned} u(r, \theta) &= \frac{1}{2\pi} \int_0^{2\pi} f(\phi) d\phi \\ &\quad + \sum_{n=1}^{\infty} \frac{r^n}{\pi R^n} \int_0^{2\pi} f(\phi) (\cos n\phi \cos n\theta + \sin n\phi \sin n\theta) d\phi \\ &= \frac{1}{2\pi} \int_0^{2\pi} f(\phi) \left(1 + 2 \sum_{n=1}^{\infty} \left(\frac{r}{R}\right)^n \cos n(\theta - \phi) \right) d\phi. \end{aligned}$$

The infinite sum in the integrand can be determined exactly as follows. Recalling the identity $\cos \alpha = \frac{1}{2}(e^{i\alpha} + e^{-i\alpha})$, we can write

$$1 + 2 \sum_{n=1}^{\infty} \left(\frac{r}{R}\right)^n \cos n(\theta - \phi) = 1 + \sum_{n=1}^{\infty} \left(\frac{r}{R}\right)^n e^{in(\theta - \phi)} + \sum_{n=1}^{\infty} \left(\frac{r}{R}\right)^n e^{-in(\theta - \phi)}.$$

But each series on the right side is a geometric series, and we know from calculus that

$$\sum_{n=1}^{\infty} z^n = \frac{z}{1-z}, \quad \text{provided that } |z| < 1.$$

Therefore we get

$$\begin{aligned} 1 + \sum_{n=1}^{\infty} \left(\frac{r}{R}\right)^n \cos n(\theta - \phi) &= 1 + \frac{re^{i(\theta - \phi)}}{R - re^{i(\theta - \phi)}} + \frac{re^{-i(\theta - \phi)}}{R - re^{-i(\theta - \phi)}} \\ &= \frac{R^2 - r^2}{R^2 + r^2 - 2rR \cos(\theta - \phi)}. \end{aligned}$$

Assembling the results, we have the following.

Theorem 4.19

(Poisson's integral formula) If f is a continuous function, then the BVP for Laplace's equation (4.52–4.54) on a circular domain of radius R is given by

$$u(r, \theta) = \frac{1}{2\pi} \int_0^{2\pi} \frac{(R^2 - r^2)f(\phi)}{R^2 + r^2 - 2rR \cos(\theta - \phi)} d\phi. \quad \square \quad (4.60)$$

Remark 4.20

Poisson's integral formula is unwieldy for calculations. But it is an important theoretical tool. For example, if we use the formula to find the temperature at the origin, we immediately get

$$u(0, 0) = \frac{1}{2\pi} \int_0^{2\pi} f(\phi) d\phi.$$

In other words, the temperature at the center of the disk is the average of the prescribed boundary temperatures. \square

Remark 4.21

(Exterior Dirichlet Problem) By the same method, we can show that the bounded solution to the *exterior* Dirichlet problem

$$\begin{aligned} u_{rr} + \frac{1}{r}u_r + \frac{1}{r^2}u_{\theta\theta} &= 0, & r > R, & 0 \leq \theta \leq 2\pi, \\ u(R, \theta) &= f(\theta), & 0 \leq \theta \leq 2\pi, \end{aligned}$$

where f is continuous, is

$$u(r, \theta) = \frac{1}{2\pi} \int_0^{2\pi} \frac{(r^2 - R^2)f(\phi)}{R^2 + r^2 - 2rR \cos(\theta - \phi)} d\phi. \quad \square$$

Solving Laplace's equation on portions of circles (wedges) and for annular domains is similar. Readers familiar with complex analysis may recall that some unusual-shaped domains can be mapped conformally onto a simple domain where Laplace's equation can be solved; conformal transformations preserve solutions to Laplace's equation, and so this method can result in a closed form solution, i.e., a formula, for the answer. Many elementary texts on complex analysis discuss this method (see, for example, Churchill (1960) for an elementary discussion).

As an aside, the most common method in practice for solving Laplace's equation on any bounded domain, regardless of its shape, is to use a numerical method. For example, in the *method of finite differences* (see Exercise 6 in Section 1.8) the derivatives are approximated by difference quotients, and the solution $u(x, y)$ is determined at discrete lattice points inside the region. This method is further discussed in Chapter 6. Another widely used method not discussed here is the *finite element method*, which also yields the approximate solution at discrete points of the domain.

General Results for Laplace's Equation

In the next few paragraphs we introduce some basic properties of solutions to Laplace's equation on bounded spatial domains in three dimensions. The results also apply to two dimensions. Many of the assertions follow from the **divergence theorem**, which states that for a smooth vector field $\phi = \phi(x, y, z)$,

$$\int_{\Omega} \operatorname{div} \phi \, dV = \int_{\partial\Omega} \phi \cdot \mathbf{n} \, dA. \quad (4.61)$$

The divergence theorem is a version of the fundamental theorem of calculus in three (or two) dimensions—it converts the integral of derivatives, a divergence, to an integral over the boundary. We know from elementary calculus that the divergence measures the local outflow per unit volume of a vector field ϕ , so the divergence theorem states that the net outflow, per unit volume, in a region Ω must equal the flux through the boundary (surface) $\partial\Omega$ of that region. Recall that the integral on the right is a flux integral through the surface oriented by the outward unit normal vector \mathbf{n} . Here we are taking a fluid flow interpretation in speaking of outflow, but the interpretation is valid for any smooth vector field. We always take Ω to be a nice region with a smooth boundary or with a boundary made up of finitely many smooth sections. There are some pathological domains on which the divergence theorem does not apply, but we do not consider those. Moreover, we always assume that the functions involved in our discussion are sufficiently smooth for the theorems to apply. For example, the functions should have two continuous partial derivatives in Ω , be continuous on $\Omega \cup \partial\Omega$, and have first partial derivatives that extend continuously to the boundary.

Two important integral identities, called Green's identities, follow from the divergence theorem. These identities are higher dimensional versions of Green's identity for Sturm–Liouville problems obtained in Section 4.2. To begin, note that if u is a scalar field and ϕ is a vector field, then

$$\operatorname{div}(u\phi) = u \operatorname{div} \phi + \phi \cdot \operatorname{grad} u$$

(see Exercise 4, Section 1.7). Integrating over the volume Ω and using the divergence theorem gives

$$\int_{\partial\Omega} u \phi \cdot \mathbf{n} \, dA = \int_{\Omega} u \operatorname{div} \phi \, dV + \int_{\Omega} \phi \cdot \operatorname{grad} u \, dV.$$

Setting $\phi = \operatorname{grad} v$ for a scalar function v then gives

$$\int_{\partial\Omega} u \operatorname{grad} v \cdot \mathbf{n} \, dA = \int_{\Omega} u \Delta v \, dV + \int_{\Omega} \operatorname{grad} v \cdot \operatorname{grad} u \, dV. \quad (4.62)$$

Here we have used the fact that $\operatorname{div}(\operatorname{grad} u) = \Delta u$, the Laplacian. In particular, if we set $v = u$, we obtain

$$\int_{\partial\Omega} u \operatorname{grad} u \cdot \mathbf{n} \, dA = \int_{\Omega} u \Delta u \, dV + \int_{\Omega} \operatorname{grad} u \cdot \operatorname{grad} u \, dV, \quad (4.63)$$

and this is **Green's first identity**. Note that in one dimension this identity is the same as

$$\int_a^b yy'' \, dx = -yy' \Big|_a^b - \int_a^b (y')^2 \, dx,$$

which is just the integration by part formula.

To obtain Green's second identity, interchange v and u in equation (4.62) and subtract that result from (4.62) to get

$$\int_{\Omega} u \Delta v \, dV = \int_{\Omega} v \Delta u \, dV + \int_{\partial\Omega} (u \operatorname{grad} v - v \operatorname{div} u) \cdot \mathbf{n} \, dA. \quad (4.64)$$

This is **Green's second identity**; it can be regarded as an integration by parts formula for the Laplacian Δ ; note how the Laplacian is taken off v and put on u and a boundary term is produced.

Notation. We often use the notation

$$\frac{du}{dn} \equiv \mathbf{n} \cdot \operatorname{grad} u$$

to denote the *normal derivative*, i.e., the derivative of u on a boundary in the direction of the outward unit normal. \square

Green's identities can be used to prove many interesting facts about problems involving Laplace's equation. To begin, we show that solutions to the Dirichlet problem are unique.

Theorem 4.22

A solution to the Dirichlet problem

$$\begin{aligned} \Delta u &= 0 \quad \text{in } \Omega, \\ u &= f(x, y, z) \quad \text{on } \partial\Omega, \end{aligned}$$

is unique. \square

By way of contradiction, assume that there are two solutions, u and v . Then the difference $w \equiv u - v$ must satisfy the problem

$$\begin{aligned} \Delta w &= 0 \quad \text{in } \Omega, \\ w &= 0 \quad \text{on } \partial\Omega. \end{aligned}$$

Multiply this PDE by w and integrate over the region Ω to get

$$\int_{\Omega} w \Delta w \, dV = 0.$$

Green's first identity (4.63) implies

$$\int_{\partial\Omega} w \operatorname{grad} w \cdot \mathbf{n} \, dA - \int_{\Omega} \operatorname{grad} w \cdot \operatorname{grad} w \, dV = 0.$$

The first integral on the left is zero because $w = 0$ on the boundary. Therefore,

$$\int_{\Omega} \text{grad } w \cdot \text{grad } w \, dV = 0.$$

Because the integrand is never negative, it follows that $\text{grad } w = 0$, or $w = \text{constant}$ in Ω . Because $w = 0$ on the boundary, the constant must be zero, and so $w = 0$ in $\Omega \cup \partial\Omega$. This means that $u = v$ in $\Omega \cup \partial\Omega$. So there cannot be two solutions. The reader should recognize the proof above as an “energy argument” of the type introduced in Section 4.3 for SLPs. \square

Another interesting property of harmonic functions satisfying Dirichlet-type boundary conditions is that they minimize the **energy integral**

$$E(w) \equiv \int_{\Omega} \text{grad } w \cdot \text{grad } w \, dV.$$

In electrostatics, for example, where w is the electric field potential, the energy E is the energy stored in the electrostatic field.

Theorem 4.23

(Dirichlet’s principle) Suppose u satisfies

$$\Delta u = 0 \text{ in } \Omega; \quad u = f \text{ on } \partial\Omega.$$

Then $E(u) \leq E(w)$ for all w satisfying $w = f$ on $\partial\Omega$. In other words, of all functions that satisfy the boundary condition, the solution to Laplace’s equation is the one that minimizes the energy. \square

To prove Dirichlet’s principle, let $w = u + v$ where $v = 0$ on the boundary $\partial\Omega$. Then

$$\begin{aligned} E(w) &= E(u + v) \\ &= \int_{\Omega} \text{grad } (u + v) \cdot \text{grad } (u + v) \, dV \\ &= \int_{\Omega} \text{grad } u \cdot \text{grad } u \, dV + 2 \int_{\Omega} \text{grad } u \cdot \text{grad } v \, dV \\ &\quad + \int_{\Omega} \text{grad } v \cdot \text{grad } v \, dV \\ &= E(u) + E(v) + 2 \int_{\Omega} \text{grad } u \cdot \text{grad } v \, dV. \end{aligned}$$

But the integral term on the right is zero by equation (4.62). And because $E(v) \geq 0$, we have $E(u) \leq E(w)$, which completes the proof. \square

EXERCISES

1. Consider the pure boundary value problem for Laplace's equation given by

$$\begin{aligned}u_{xx} + u_{yy} &= 0, & 0 < x < l, & 0 < y < 1, \\u(0, y) &= 0, & u(l, y) &= 0, & 0 < y < 1, \\u(x, 0) &= 0, & u(x, 1) &= G(x), & 0 < x < l.\end{aligned}$$

Use the separation of variables method to find an infinite series representation of the solution. Here, take $u(x, y) = \phi(x)\psi(y)$ and identify a boundary value problem for $\phi(x)$; proceed as in other separation of variables problems.

2. Find an infinite series representation for the solution to the equilibrium problem

$$\begin{aligned}u_{xx} + u_{yy} &= 0, & 0 < x < a, & 0 < y < b, \\u_x(0, y) &= u_x(a, y) = 0, & 0 < y < b, \\u(x, 0) &= f(x), & u(x, b) &= 0, & 0 < x < a.\end{aligned}$$

Interpret this problem in the context of steady heat flow.

3. Solve the boundary value problem

$$\begin{aligned}\Delta u &= 0, & r < R, & 0 \leq \theta < 2\pi, \\u(R, \theta) &= 4 + 3 \sin \theta, & 0 \leq \theta < 2\pi.\end{aligned}$$

4. Show that the solution $u = u(r, \theta)$ to the *exterior* boundary value problem

$$\begin{aligned}\Delta u &= 0, & r > R, & 0 \leq \theta < 2\pi, \\u(R, \theta) &= f(\theta), & 0 \leq \theta < 2\pi,\end{aligned}$$

is given by

$$u(r, \theta) = \frac{1}{2\pi} \int_0^{2\pi} \frac{(r^2 - R^2)f(\phi)}{R^2 + r^2 - 2rR \cos(\theta - \phi)} d\phi.$$

Hint: Follow the example in the book but choose the other bounded solution in equation (4.56).

5. Solve

$$\begin{aligned}\Delta u &= 0, & r > 1, & 0 \leq \theta < 2\pi, \\u(1, \theta) &= \cos \theta, & 0 < \theta < 2\pi.\end{aligned}$$

6. Find an infinite series solution to the following boundary value problem on a wedge:

$$\begin{aligned}\Delta u &= 0, \quad r < R, \quad 0 \leq \theta < \pi/2, \\ u(R, \theta) &= f(\theta), \quad 0 < \theta < \pi/2, \\ u(r, 0) &= 0, \quad u(r, \pi/2) = 0, \quad 0 < r < R.\end{aligned}$$

7. Solve the boundary value problem in Exercise 5 with the boundary conditions along the edges $\theta = 0$, $\theta = \pi/2$ replaced by

$$u(r, 0) = 0, \quad u_\theta(r, \pi/2) = 0, \quad 0 < r < R.$$

8. Solve the Dirichlet problem on an annulus:

$$\begin{aligned}\Delta u &= 0, \quad 1 < r < 2, \quad 0 \leq \theta < 2\pi, \\ u(1, \theta) &= \sin \theta, \quad 0 < \theta < 2\pi, \\ u(2, \theta) &= \cos \theta, \quad 0 < \theta < 2\pi.\end{aligned}$$

9. Find a bounded solution to the exterior boundary value problem

$$\begin{aligned}\Delta u &= 0, \quad r > R, \\ u &= 1 + 2 \sin \theta \text{ on } r = R.\end{aligned}$$

10. Prove Dirichlet's principle for the Neumann problem: Let

$$E(w) \equiv \frac{1}{2} \int_{\Omega} \text{grad } w \cdot \text{grad } w \, dV - \int_{\partial\Omega} h w \, dA.$$

If u is the solution to the BVP

$$\begin{aligned}\Delta u &= 0 \text{ in } \Omega, \\ \mathbf{n} \cdot \text{grad } u &= h \text{ on } \partial\Omega,\end{aligned}$$

then $E(u) \leq E(w)$ for all w sufficiently smooth. Observe that the average value of h on the boundary is zero.

11. Show that a necessary condition for the Neuman problem

$$\begin{aligned}\Delta u &= f \text{ in } \Omega, \\ \mathbf{n} \cdot \text{grad } u &= h \text{ on } \partial\Omega,\end{aligned}$$

to have a solution is that

$$\int_{\Omega} f \, dV = \int_{\partial\Omega} g \, dA.$$

Interpret this result in the context of heat conduction.

12. Find radial solutions $u = u(\rho)$ of the equation

$$\Delta u = k^2 u$$

in spherical coordinates. Hint: Let $u = \rho w$.

13. In three dimensions consider the radiation boundary value problem

$$\begin{aligned} \Delta u - cu &= 0 \quad \text{in } \Omega, \\ \mathbf{n} \cdot \text{grad } u + au &= 0 \quad \text{on } \partial\Omega, \end{aligned}$$

where $a, c > 0$ and Ω is a bounded region. Show that the only solution is $u = 0$. Hint: Use an energy argument. Multiply the PDE by u , integrate, and then use Green's first identity.

14. Use the last exercise to show that solutions to the boundary value problem

$$\begin{aligned} \Delta u - cu &= g(x, y, z) \quad (x, y, z) \in \Omega, \\ n \cdot \text{grad } u + au &= f(x, y, z) \quad \text{on } \partial\Omega, \end{aligned}$$

are unique.

15. Suppose $u = u(x, y, z)$ satisfies the Neumann problem

$$\begin{aligned} \Delta u &= 0, \quad \text{in } \Omega, \\ \mathbf{n} \cdot \text{grad } u &= 0 \quad \text{on } \partial\Omega. \end{aligned}$$

Show that u must be constant on Ω .

16. Suppose $u = u(x, y, z)$ satisfies the Robin problem

$$\begin{aligned} \Delta u &= 0 \quad \text{in } \Omega, \\ \frac{du}{dn} + au &= 0 \quad \text{on } \partial\Omega. \end{aligned}$$

Show that solutions are unique if $a > 0$.

17. Show that the Poisson integral formula can be written in vector form as

$$u(\mathbf{x}) = \frac{R^2 - |\mathbf{x}|^2}{2\pi R} \int_{|\mathbf{y}|=R} \frac{u(\mathbf{y})}{|\mathbf{x} - \mathbf{y}|^2} ds,$$

where the integral is a line integral with respect to arclength over the circle $|\mathbf{y}| = R$.

18. Show that the Neumann problem on the unit disk, $\Delta u = 0$ in $r < 1$, $u = \sin^2 \theta$ on $r = 1$, does not have a solution.
19. Consider the Dirichlet problem between two spheres: $\Delta u = 0$ in $R_1 < \rho < R_2$, and $u = a$ on $\rho = R_1$, $u = b$ on $\rho = R_2$. Find the solution and sketch graphs of u vs. ρ in the cases $a < b$ and $b < a$.

4.5 Cooling of a Sphere

In this section we present the solution to a classical problem in three dimensions, the cooling of a sphere. The symmetries in the problem permits us to reduce the dimension of the problem to one spatial dimension (the radius) and time, and we can follow the same procedures as in previous sections.

The problem is this: Given a sphere whose initial temperature depends only on the distance from the center (e.g., a constant initial temperature) and whose boundary is kept at a constant temperature, predict the temperature at any point inside the sphere at a later time. This is the problem, for example, of determining the temperature in a spherically-shaped object, e.g., a potato, that has been placed in a hot oven. The reader could conjecture that this problem is important for medical examiners who want to determine the time of an individual's death by measuring temperatures in brain tissue. Early researchers, notably Kelvin, used this problem to determine the age of the earth based on conjectures about its initial temperature and its temperature today.

This problem is reminiscent of Newton's law of cooling, which is encountered in ordinary differential equations texts. It states that the rate at which a body cools is proportional to the difference of its temperature and the temperature of the environment. Quantitatively, if $T = T(t)$ is the temperature of a body and T_e is the temperature of its environment, then $T'(t) = -h(T - T_e)$, where h is the constant heat loss coefficient. But the reader should note that this law applies only in the case that the body has a *uniform, homogeneous temperature*. In the PDE problem we are considering, the temperature may vary radially throughout the body.

For simplicity, we consider a sphere of radius $\rho = \pi$ whose initial temperature is $T_0 = \text{constant}$. We assume the boundary is maintained at zero degrees for all time $t > 0$. In general, the temperature u inside the sphere depends on three spherical coordinates, ρ , θ , ϕ , and time. But reflection reveals that the temperature will depend only on the distance ρ from the center of the sphere and on time; that is, $u = u(\rho, t)$. There are no variations in the initial or boundary conditions that would cause gradients to change in the θ and ϕ coordinate directions. Evidently, the temperature must satisfy the heat equation

$$u_t = k\Delta u,$$

where k is the diffusivity and Δ is the Laplacian (see Section 1.7). Because u does not depend on ϕ and θ , the Laplacian takes on a particularly simple form:

$$\Delta = \frac{\partial^2}{\partial \rho^2} + \frac{2}{\rho} \frac{\partial}{\partial \rho}$$

(see Section 1.8). Therefore, we can formulate the model as

$$u_t = k \left(u_{\rho\rho} + \frac{2}{\rho} u_\rho \right), \quad 0 < \rho < \pi, \quad t > 0, \quad (4.65)$$

$$u(\pi, t) = 0, \quad t > 0, \quad (4.66)$$

$$u(\rho, 0) = T_0, \quad 0 \leq \rho < \pi. \quad (4.67)$$

There is an implied boundary condition at $\rho = 0$, namely that the temperature should remain bounded.

To solve problem (4.65–4.67) we assume $u(\rho, t) = y(\rho)g(t)$. Substituting into the PDE and separating variables gives, in the usual way,

$$\frac{g'(t)}{kg(t)} = \frac{y''(\rho) + \frac{2}{\rho}y'(\rho)}{y(\rho)} = -\lambda,$$

where $-\lambda$ is the separation constant. Substituting $u(\rho, t) = y(\rho)g(t)$ into the boundary condition (4.66) gives $y(\pi) = 0$, and the boundedness of u at $\rho = 0$ forces $y(0)$ to be bounded. Therefore, we get the boundary value problem

$$-y''(\rho) - \frac{2}{\rho}y'(\rho) = \lambda y(\rho), \quad 0 < \rho < \pi, \quad (4.68)$$

$$y(0) \text{ bounded}, \quad y(\pi) = 0. \quad (4.69)$$

This is a *singular* SLP.

If $\lambda = 0$, then the equation is Cauchy–Euler, having the form $-y'' - \frac{2}{\rho}y' = 0$. The general solution is $y = a/\rho + b$. The boundedness condition at zero forces $a = 0$, and $y(\pi) = 0$ implies $b = 0$. Therefore $\lambda = 0$ is not an eigenvalue. If $\lambda \neq 0$, it may not be clear to the reader how to solve the variable-coefficient equation (4.68). However, if we introduce the new dependent variable $Y = Y(\rho)$ defined by

$$Y(\rho) = \rho y(\rho),$$

then (4.68) transforms into the familiar equation

$$-Y''(\rho) = \lambda Y(\rho).$$

If $\lambda > 0$, then $Y = a \cos \sqrt{\lambda}\rho + b \sin \sqrt{\lambda}\rho$, which gives

$$y(\rho) = \frac{1}{\rho} \left(a \cos \sqrt{\lambda}\rho + b \sin \sqrt{\lambda}\rho \right).$$

We must have $a = 0$ because $\cos \sqrt{\lambda}\rho/\rho$ is unbounded at $\rho = 0$. Therefore, applying the boundary condition $y(\pi) = 0$ then gives

$$b \sin \sqrt{\lambda}\pi = 0,$$

which in turn yields the eigenvalues

$$\lambda = \lambda_n = n^2, \quad n = 1, 2, \dots$$

The eigenfunctions are

$$y_n(\rho) = \frac{\sin n\rho}{\rho}, \quad n = 1, 2, \dots$$

We leave it as an exercise to show that there are no negative eigenvalues (see Exercise 1).

The corresponding solutions to the time equation for $g(t)$ are easily found to be $g_n(t) = c_n e^{-n^2 kt}$. Thus we have determined infinitely many solutions of the form

$$u_n(\rho, t) = c_n e^{-n^2 kt} \frac{\sin n\rho}{\rho}, \quad n = 1, 2, \dots,$$

that satisfy the PDE and the boundary conditions. To satisfy the initial condition (4.67) we form the linear combination

$$u(\rho, t) = \sum_{n=1}^{\infty} c_n e^{-n^2 kt} \frac{\sin n\rho}{\rho}.$$

Applying the initial condition gives

$$u(\rho, 0) = T_0 = \sum_{n=1}^{\infty} c_n \frac{\sin n\rho}{\rho},$$

or

$$T_0 \rho = \sum_{n=1}^{\infty} c_n \sin n\rho.$$

The right side of this equation is the Fourier sine series of the function $T_0 \rho$ on the interval $[0, \pi]$. Therefore, the Fourier coefficients c_n are given by

$$c_n = \frac{2}{\pi} \int_0^{\pi} T_0 \rho \sin n\rho \, d\rho.$$

The integral can be calculated by hand using integration by parts. We get

$$c_n = (-1)^{n+1} \frac{2T_0}{n}.$$

In summary, we have derived the solution formula for the model (4.65–4.67):

$$u(\rho, t) = \sum_{n=1}^{\infty} (-1)^{n+1} \frac{2T_0}{n} e^{-n^2 kt} \frac{\sin n\rho}{\rho}. \quad (4.70)$$

This formula gives the temperature at time t at a distance ρ from the center of the sphere.

EXERCISES

1. Show that the eigenvalue problem (4.68–4.69) has no negative eigenvalues.
2. In the cooling of the sphere problem take $R = \pi$ inches, $T_0 = 37$ degrees Celsius, and $k = 5.58$ inches-squared per hour. Using (4.70), plot the temperature at the center of the sphere as a function of time; take $t = 0$ to $t = 1$ hour.
3. This problem deals with the cooling of a sphere with a radiation boundary condition. A spherical ball of radius R has a diffusivity k and initial temperature $u = f(\rho)$, $0 \leq \rho \leq R$, which depends only on the distance ρ from the center. Heat radiates from the surface of the sphere via the law

$$u_\rho(R, t) = -hu(R, t),$$

where h is a positive constant and $Rh < 1$. Find a formula for the temperature $u(\rho, t)$ in the sphere. Hint: Find the eigenvalues λ_n as the positive roots of the equation

$$\tan R\lambda = \frac{R\lambda}{1 - Rh}.$$

Next, take $R = \pi$ inches, $k = 5.58$ inches-squared per hour, $f(\rho) = 37$ degrees Celsius, and $h = 0.1$ per inch, and calculate a four term approximate solution to the temperature function.

4. Consider a sphere of unit radius on which there is a prescribed potential u depending only on the spherical coordinate angle ϕ (see Section 1.8). This exercise deals with using separation of variables to find an expression for the bounded potential that satisfies Laplace's equation inside the sphere. The boundary value problem is

$$\Delta u = 0, \quad 0 < \rho < 1, \quad 0 < \phi < \pi; \quad u(1, \phi) = f(\phi), \quad 0 \leq \phi \leq \pi,$$

where $u = u(\rho, \phi)$. Notice that u will not depend on the polar angle θ because of the symmetry in the boundary condition.

- (a) Assume $u = R(\rho)Y(\phi)$ and derive the two equations

$$-\left((1-x^2)y'\right)' = \lambda y, \quad -1 < x < 1; \quad \left(\rho^2 R'\right)' - \lambda R = 0,$$

where $x = \cos \phi$ and $y(x) = Y(\arccos x)$.

- (b) The equation for y in part (a) is *Legendre's differential equation*, and it has bounded, continuous solutions on $[-1, 1]$ when

$$\lambda = \lambda_n = n(n+1), \quad y = y_n(x) = P_n(x), \quad n = 0, 1, 2, \dots,$$

where the P_n are polynomial functions called the **Legendre polynomials**. The Legendre polynomials are orthogonal on $[-1, 1]$, and they are given by Rodrigues' formula

$$P_n(x) = \frac{1}{n!2^n} \frac{d^n}{dx^n} [(x^2 - 1)^n].$$

Go through a formal calculation and derive a formula for the solution to the given BVP in the form

$$u(\rho, \phi) = \sum_{n=0}^{\infty} c_n \rho^n P_n(\cos \phi),$$

where

$$c_n = \frac{1}{\|P_n\|^2} \int_0^\pi f(\phi) P_n(\cos \phi) \sin \phi \, d\phi.$$

(c) Find the first four Legendre polynomials using Rodrigues' formula.

(d) If $f(\phi) = \sin \phi$, find an approximate solution.

5. Estimate the age of the earth. Use the data in Exercise 5 of Section 2.4.

4.6 Diffusion in a Disk

In the last section we solved a diffusion problem in spherical coordinates and found, assuming angular symmetry, that it was a routine application of the separation of variables method. In this section we solve a diffusion problem in polar coordinates; we will find the task is not so routine because we obtain a differential equation (**Bessel's equation**) that may be unfamiliar to the reader. A computer algebra system may help illuminate some of the steps along the way. (The instructor may find that this problem is well suited for presentation in a computer laboratory setting.).

Consider a circular, planar disk of radius R whose initial temperature is a function of the radius alone and whose boundary is held at zero degrees. We are interested in how heat diffuses throughout the disk. Intuition dictates that the temperature u in the disk depends only on time and the distance r from the center, or $u = u(r, t)$. We can make this assumption because there is nothing in the initial or boundary condition to cause heat to diffuse in an angular direction—heat flows only along rays emanating from the origin.

We know that u must satisfy the two-dimensional heat equation $u_t = k\Delta u$ in $0 < r < R$, where k is the diffusivity and Δ is the Laplacian in polar coordinates, given in Section 1.8. Therefore the PDE is

$$u_t = k \left(u_{rr} + \frac{1}{r} u_r \right), \quad 0 < r < R, \quad t > 0. \quad (4.71)$$

The boundary condition is

$$u(R, t) = 0, \quad t > 0, \quad (4.72)$$

and the initial condition is

$$u(r, 0) = f(r), \quad 0 \leq r < R, \quad (4.73)$$

where f is a given radial temperature distribution. It is understood that the temperature should be bounded at $r = 0$. Equations (4.71–4.73) define the initial boundary value problem we want to solve.

Now separate variables. Taking $u(r, t) = y(r)g(t)$, the PDE splits into

$$\frac{g'(t)}{kg(t)} = \frac{y''(r) + \frac{1}{r}y'(r)}{y(r)} = -\lambda.$$

The equation for $g(t)$ is solved in the usual way to obtain

$$g(t) = e^{-\lambda kt}.$$

The radial equation is

$$y''(r) + \frac{1}{r}y'(r) = -\lambda y(r). \quad (4.74)$$

Upon multiplying by r , we can rewrite this equation as

$$-\left(ry'(r)\right)' = \lambda ry(r), \quad (4.75)$$

which is **Bessel's equation**. Condition (4.72) leads to the boundary condition

$$y(R) = 0, \quad (4.76)$$

and we impose the boundedness requirement

$$y(0) \text{ bounded.} \quad (4.77)$$

Note that the ODE (4.75), along with the boundary conditions (4.76–4.77), is a *singular* Sturm–Liouville problem.

It is easily seen that $\lambda = 0$ is not an eigenvalue; in this case the general solution of (4.75) is $y = a + b \ln r$; and $b = 0$ by boundedness and $a = 0$ by the condition $y(R) = 0$. We leave it as an exercise using an energy argument to show that there are no negative eigenvalues (Exercise 1). Therefore we consider the case where λ is positive. In the last section we found a simple substitution for a similar equation $y'' + (2/\rho)y' = \lambda y$ that transformed it to a familiar

equation; but Bessel's equation (4.74) is slightly different (by just a factor of 2 in one term), and a simple change of variables does not work. A successful approach involves the use of power series methods for differential equations; that is, one assume a solution of the form

$$y(r) = \sum_{n=0}^{\infty} a_n r^n$$

and substitute into (4.75) to determine the coefficients a_0, a_1, a_2, \dots . This calculation, which we do not perform, ultimately leads to two linearly independent solutions of (4.74), denoted in the literature by $J_0(\sqrt{\lambda}r)$ and $Y_0(\sqrt{\lambda}r)$; so the general of (4.75) is

$$y(r) = c_1 J_0(\sqrt{\lambda}r) + c_2 Y_0(\sqrt{\lambda}r)$$

where c_1 and c_2 are arbitrary constants.

Remark 4.24

Maple and MATLAB, for example, denote these special functions $J_0(z)$ and $Y_0(z)$ by `BesselJ`, `BesselY` and `besselj`, `bessely`, respectively. These are the **Bessel functions** of order zero. Their properties, graphs, and values are catalogued in these computer algebra systems as well as handbooks. \square

Plots of the Bessel functions are shown in Figure 4.4. It is clear that $Y_0(z)$ blows up near $z = 0$; in fact, it can be shown that $Y_0(z)$ behaves like $\ln z$ for small, positive z . Therefore, we discard the second term in the solution to maintain boundedness; so we set $c_2 = 0$. Therefore, we have the bounded solution to the differential equation (4.75) as

$$y(r) = c_1 J_0(\sqrt{\lambda}r). \quad (4.78)$$

The Bessel function $J_0(z)$ is a nicely behaved oscillatory function. It is similar to the cosine function, but its oscillations decay as z increases. It has infinitely many zeros z_n , $n = 1, 2, 3, \dots$; the first few are $z_1 = 2.405$, $z_2 = 5.520$, $z_3 = 8.654$, $z_4 = 11.790$. Its series representation can be found as

$$J_0(z) = \sum_{n=0}^{\infty} \frac{(-1)^n}{n! 2^{2n}} z^{2n}.$$

One can also show that for large z ,

$$J_0(z) \sim \sqrt{\frac{2}{\pi z}} \cos\left(z - \frac{\pi}{4}\right),$$

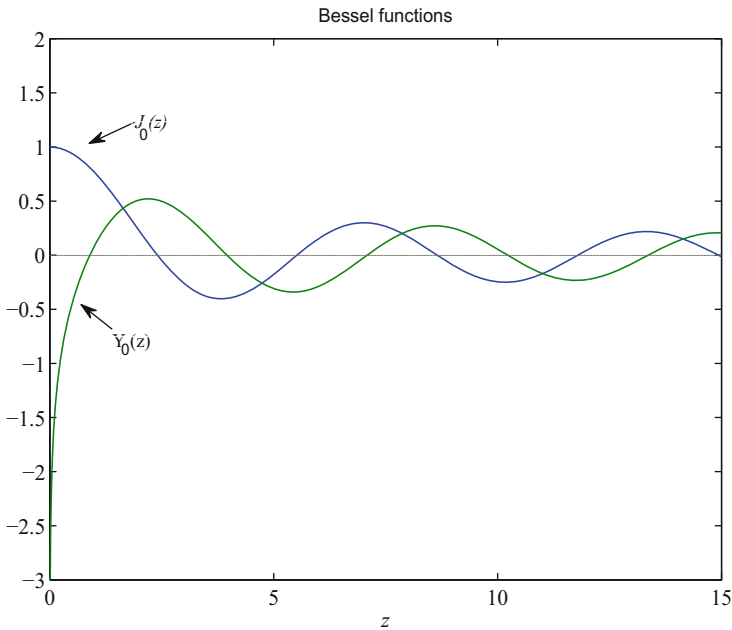

Figure 4.4 MATLAB plots of the Bessel functions $J_0(z)$ and $Y_0(z)$ for $0 \leq z \leq 15$

which shows its “decaying cosine” behavior.

Now we apply the boundary condition (4.76) to (4.78), and we obtain

$$y(R) = c_1 J_0(\sqrt{\lambda}R) = 0.$$

Thus

$$\sqrt{\lambda}R = z_n, \quad z = 1, 2, 3, \dots,$$

where the z_n are the zeros of J_0 . Consequently, the eigenvalues are

$$\lambda_n = \frac{z_n^2}{R^2}, \quad n = 1, 2, 3, \dots,$$

and the corresponding eigenfunctions are

$$y_n(r) = J_0\left(\frac{z_n r}{R}\right), \quad n = 1, 2, 3, \dots$$

In summary, we have constructed solutions $g_n(t)y_n(r)$ of the form

$$e^{-\lambda_n kt} J_0\left(\frac{z_n r}{R}\right), \quad n = 1, 2, 3, \dots,$$

that satisfy the PDE and the boundary conditions.

To satisfy the initial condition (4.73) we form the linear combination

$$u(r, t) = \sum_{n=1}^{\infty} c_n e^{-\lambda_n k t} J_0\left(\frac{z_n r}{R}\right). \quad (4.79)$$

The initial condition forces

$$u(r, 0) = f(r) = \sum_{n=1}^{\infty} c_n J_0\left(\frac{z_n r}{R}\right).$$

To find the c_n we use *orthogonality*. This last equation is a Fourier–Bessel expansion, and the Bessel functions $J_0\left(\frac{z_n r}{R}\right)$ satisfy the orthogonality condition

$$\int_0^R J_0\left(\frac{z_n r}{R}\right) J_0\left(\frac{z_m r}{R}\right) r dr = 0, \quad n \neq m. \quad (4.80)$$

(See Exercise 2.) The factor r in the integrand is a weight function, and the Bessel functions $J_0\left(\frac{z_n r}{R}\right)$ are orthogonal with respect to r . The orthogonality allows us to determine the coefficients in the standard way: Multiply equation (4.80) by $r J_0\left(\frac{z_m r}{R}\right)$ and integrate from $r = 0$ to $r = R$, interchange the summation and the integral, and then use the weighted orthogonality relation to collapse the infinite sum to one term. We obtain

$$\int_0^R f(r) J_0\left(\frac{z_n r}{R}\right) r dr = c_n \|J_0\left(\frac{z_n r}{R}\right)\|^2,$$

where

$$\|J_0\left(\frac{z_n r}{R}\right)\|^2 = \int_0^R J_0\left(\frac{z_n r}{R}\right)^2 r dr.$$

Therefore, the coefficients are given by

$$c_n = \frac{\int_0^R f(r) J_0\left(\frac{z_n r}{R}\right) r dr}{\|J_0\left(\frac{z_n r}{R}\right)\|^2}. \quad (4.81)$$

In conclusion, the formal solution to the initial boundary value problem (4.71–4.73) is given by (4.79) with coefficients given by (4.81).

In the exercises the reader is asked to calculate this solution numerically in special cases.

We conclude by making some brief remarks about special functions. The Bessel functions J_0 and Y_0 encountered above are just two examples of large classes of Bessel functions. Problems in cylindrical geometry, for example, the vibrations of a drum head, lead to such functions. Moreover, other special functions (Legendre polynomials, Laguerre polynomials, and others) occur in a similar way for problems in other coordinate systems and domains. That is, they occur as solutions to eigenvalue problems for ordinary differential equations

that arise from the separation of variables process. Generally, special functions arising in this manner possess orthogonality properties that give the expansion of the solution in terms of those functions.

EXERCISES

1. Show that the eigenvalue problem (4.75–4.77) has no negative eigenvalues. Hint: Use an energy argument—multiply the ODE by y and integrate from $r = 0$ to $r = R$; use integration by parts and use the boundedness at $r = 0$ to get the boundary term to vanish.
2. Derive the weighted orthogonality relation (4.80). Hint: Proceed as in Section 4.4 for regular Sturm–Liouville problems.
3. For the initial boundary value problem (4.71–4.73) take $R = 1$, $k = 0.25$, and $f(r) = 5r^3(1 - r)$. Use a computer algebra program to determine a 3-term approximation to the solution using (4.79). Sketch radial temperature profiles $u(r, t)$ for several fixed values of t .
4. When $R = 1$ sketch the first four eigenfunctions $J_0(\frac{z_n r}{R})$, $n = 1, 2, 3, 4$.
5. (Computer algebra project) Consider the boundary value problem

$$\begin{aligned}y'' + axy &= 0, & 0 < x < L, \\y'(0) &= 0, & y(L) = 0,\end{aligned}$$

where a is a positive constant. Find the smallest positive value of L for which the boundary value problem has a nontrivial solution. The solution is that L can be calculated from the equation

$$\frac{2}{3}\sqrt{a}L^{2/3} = 1.86635.$$

Hint: In your software program use the differential equation solver to find the general solution as a linear combination of the two Bessel functions $J_{1/3}$ and $Y_{1/3}$; use the left boundary condition in limiting form to determine one constant in terms of the other, and then use the right boundary condition to determine the appropriate value of L .

4.7 Sources on Bounded Domains

Readers should be familiar with methods for solving ordinary differential equations with source, or forcing, terms. This topic is facilitated by having the notion

of a general solution to the equation. The *general solution* to the second-order linear equation

$$Ly \equiv y'' + a(x)y' + b(x)y = f(x)$$

is $y(x) = y_h(x) + y_p(x)$ where y_h is the general solution to the homogeneous equation, $Ly_h = 0$, and y_p is any particular solution to the nonhomogeneous equation, $Ly_p = f(x)$. For simple source terms, particular solutions are usually found by the method of undetermined coefficients (judicious guessing) or by a general formula called the variation of parameters formula. (See Appendix A).

For partial differential equations the situation is more complicated. We introduce several techniques to deal with both nonhomogeneous equations and nonhomogeneous boundary conditions on bounded spatial domains for the heat equation, wave equation, and Laplace's equation.

One obvious approach is to use the linearity of the equation and boundary conditions to split a problem into simpler forms, essentially breaking apart the inhomogenieties in the problem. Consider the initial BVP (P) for the heat equation,

$$(P) : \begin{cases} u_t - ku_{xx} = f(x, t), & a < x < b, \quad t > 0, \\ u(a, t) = b_1(t), \quad u(b, t) = b_2(t), & t > 0, \\ u(x, 0) = g(x), & t > 0. \end{cases}$$

Now consider the two problems

$$(P_1) : \begin{cases} v_t - kv_{xx} = 0, & a < x < b, \quad t > 0, \\ v(a, t) = b_1(t), \quad v(b, t) = b_2(t), & t > 0, \\ v(x, 0) = g(x), & t > 0, \end{cases}$$

and

$$(P_2) : \begin{cases} w_t - kw_{xx} = f(x, t), & a < x < b, \quad t > 0, \\ w(a, t) = 0, \quad w(b, t) = 0, & t > 0, \\ w(x, 0) = 0, & t > 0. \end{cases}$$

(P_1) is the same problem as (P) with no source term, and (P_2) is the same problem as (P) with homogeneous boundary conditions. Using linearity, it is easy to see that that the solution u to (P) is

$$u(x, t) = v(x, t) + w(x, t),$$

where v and w are the solutions to (P_1) and (P_2) , respectively. Therefore, we have broken down (P) into two simpler problems. The initial condition is handled by Fourier series.

We now treat several cases. First we use Duhamel's principle (see Chapter 2 for the unbounded domain case) to show that source terms can put into initial conditions. An example is reviewed for the heat equation, but the procedure works equally well for the wave equation by placing the source in the initial condition for velocity.

Example 4.25

(Duhamel's Principle) Consider a simple diffusion model given by

$$u_t - ku_{xx} = f(x, t), \quad 0 < x < \pi, \quad t > 0, \quad (4.82)$$

$$u(0, t) = u(\pi, t) = 0, \quad t > 0, \quad (4.83)$$

$$u(x, 0) = 0, \quad 0 < x < \pi. \quad (4.84)$$

Interpreted in the context of heat flow, $u = u(x, t)$ is the temperature of a rod whose initial temperature is zero and whose ends are maintained at zero degrees. It is the heat source $f(x, t)$ that is driving the system.

The simplest way to solve (4.82–4.84) is to use Duhamel's principle as formulated in Section 2.5 for initial value problems on infinite domains. On bounded domains the principle is the same. It states that the solution of (4.82–4.84) is given by

$$u(x, t) = \int_0^t w(x, t - \tau, \tau) d\tau,$$

where $w = w(x, t, \tau)$ is the solution to the homogeneous problem

$$w_t - kw_{xx} = 0, \quad 0 < x < \pi, \quad t > 0,$$

$$w(0, t, \tau) = w(\pi, t, \tau) = 0, \quad t > 0,$$

$$w(x, 0, \tau) = f(x, \tau), \quad 0 < x < \pi.$$

Recall that τ is a parameter. We have already solved this problem in Section 4.1.

We have

$$w(x, t, \tau) = \sum_{n=1}^{\infty} c_n e^{-n^2 k t} \sin nx,$$

where

$$c_n = c_n(\tau) = \frac{2}{\pi} \int_0^{\pi} f(x, \tau) \sin nx \, dx.$$

Notice that the Fourier coefficients c_n depend on the parameter τ . So, the solution to (4.82–4.84) is

$$u(x, t) = \int_0^t \left(\sum_{n=1}^{\infty} c_n(\tau) e^{-n^2 k(t-\tau)} \sin nx \right) d\tau. \quad (4.85)$$

For example, solve (4.82–4.84) when $f(x, t) = \sin x$. Easily the Fourier coefficients are given by $c_n = 0$, $n > 1$, $c_1 = 1$. Then the solution is

$$\begin{aligned} u(x, t) &= \int_0^t c_1 e^{-k(t-\tau)} \sin x d\tau \\ &= \frac{1}{k} (1 - e^{-kt}) \sin x. \quad \square \end{aligned}$$

Remark 4.26

In the preceding example, the limit of the solution as $t \rightarrow \infty$ is

$$\lim_{t \rightarrow \infty} u(x, t) = (1/k) \sin x.$$

Notice that this is the same as the steady-state solution, i.e., the time-independent solution of the system

$$\begin{aligned} u_t - ku_{xx} &= \sin x, & 0 < x < \pi, & t > 0, \\ u(0, t) &= u(\pi, t) = 0, & t > 0, \\ u(x, 0) &= 0, & 0 < x < \pi, \end{aligned}$$

found by solving $-U''(x) = \sin x$, $U(0) = U(\pi) = 0$.

This is true in general. If the source term in (4.82–4.84) in the heat equation depends only on x , or $f(x, t) = F(x)$, then as $t \rightarrow \infty$ the solution to (4.82–4.84) approaches the steady-state solution found by solving $-U''(x) = F(x)$, $U(0) = U(\pi) = 0$. \square

Equations with sources can also be solved by an **eigenfunction method**. The first step is to find the eigenfunctions of the Sturm–Liouville problem associated with the *homogeneous* problem, with no sources.

Example 4.27

In the case of (4.82–4.84) the eigenvalues and eigenfunctions of the homogeneous problems are (see Section 4.1)

$$\lambda_n = n^2, \quad y_n(x) = \sin nx, \quad n = 1, 2, \dots$$

Then we assume a solution of the *nonhomogeneous problem* (4.82–4.84) of the form

$$u(x, t) = \sum_{n=1}^{\infty} g_n(t) \sin nx, \tag{4.86}$$

where the $g_n(t)$ are to be found. We determine the $g_n(t)$ by substituting this expression for u into the PDE (4.82), along with the expression for the eigenfunction expansion for f , namely,

$$f(x, t) = \sum_{n=1}^{\infty} f_n(t) \sin nx.$$

In this last expansion, the $f_n(t)$ are known because f is known; the $f_n(t)$ are the Fourier coefficients

$$f_n(t) = \frac{2}{\pi} \int_0^{\pi} f(x, t) \sin nx dx. \tag{4.87}$$

Carrying out this substitutions, we get

$$\frac{\partial}{\partial t} \sum_{n=1}^{\infty} g_n(t) \sin nx - k \frac{\partial^2}{\partial x^2} \sum_{n=1}^{\infty} g_n(t) \sin nx = \sum_{n=1}^{\infty} f_n(t) \sin nx,$$

or

$$\sum_{n=1}^{\infty} g'_n(t) \sin nx + k \sum_{n=1}^{\infty} n^2 g_n(t) \sin nx = \sum_{n=1}^{\infty} f_n(t) \sin nx.$$

Collecting the coefficients of the independent eigenfunctions $\sin nx$, we obtain

$$g'_n(t) + n^2 k g_n(t) = f_n(t),$$

which is a linear ordinary differential equation for the unknown $g_n(t)$. It can be solved in the standard way by multiplying by the integrating factor $e^{n^2 kt}$ and then integrating both sides. After some straightforward manipulation we obtain

$$g_n(t) = g_n(0)e^{-n^2 kt} + \int_0^t f_n(\tau)e^{-n^2 k(t-\tau)} d\tau.$$

To obtain the values of $g_n(0)$ we substitute the initial condition into (4.86) to get

$$\sum_{n=1}^{\infty} g_n(0) \sin nx = 0,$$

which implies $g_n(0) = 0$ for all n . Therefore, we have determined the $g_n(t)$, and the solution to the problem (4.82–4.84) is

$$u(x, t) = \sum_{n=1}^{\infty} \left(\int_0^t f_n(\tau)e^{-n^2 k(t-\tau)} d\tau \right) \sin nx, \quad (4.88)$$

where the $f_n(t)$ are given by (4.87). This solution formula (4.88) is the same as the solution formula (4.85) obtained by Duhamel's principle. \square

In summary, in the eigenfunction method for solving problems with sources we expand both the source f and the assumed solution u in terms of the eigenfunctions of the homogeneous problem. Substituting these expansions into the PDE leads to ODEs for the coefficients in the eigenfunction expansion for u . Solving these ODEs for the coefficients then gives the solution u as an eigenfunction expansion. Whereas Duhamel's principle is applied to initial value problems (evolution problems), the eigenfunction expansion method can be applied to all types problems, including equilibrium problems associated with Laplace's equation.

To apply the separation of variables method we need homogeneous boundary conditions. If boundary conditions are nonhomogeneous, we can often make a change of the dependent variable that leads to homogeneous ones.

Example 4.28

(**Homogenizing the boundary conditions**) Consider the problem

$$\begin{aligned}u_t - 3u_{xx} &= 0, \quad 0 < x < 1, \quad t > 0, \\u(0, t) &= 2e^{-t}, \quad u(1, t) = 1, \\u(x, 0) &= x^2, \quad 0 < x < 1.\end{aligned}$$

For the diffusion equation we can always make a transformation of the dependent function to force zero boundary conditions at the expense of introducing a source term in the PDE. Define $w(x, t)$ to be the function $u(x, t)$ minus a *linear function of x* that satisfies the boundary conditions. That is, take

$$w(x, t) = u(x, t) - \left(2e^{-t} + (1 - 2e^{-t})x\right).$$

Then w solves the problem

$$\begin{aligned}w_t - 3w_{xx} &= 2e^{-t}(1 - x), \quad 0 < x < 1, \quad t > 0, \\w(0, t) &= w(1, t) = 0, \quad t > 0, \\w(x, 0) &= x^2 + x, \quad 0 < x < 1.\end{aligned}$$

This problem can be solved using the eigenfunction as in the last example. \square

Remark 4.29

(**Steady heat source**) For the heat equation with a steady source,

$$\begin{aligned}u_t - ku_{xx} &= f(x), \quad a < x < b, \quad t > 0, \\u(a, t) &= A, \quad u(b, t) = B, \quad t > 0, \\u(x, 0) &= g(x), \quad a < x < b,\end{aligned}$$

where A and B are constant, the equilibrium temperature $U = U(x)$ satisfies

$$-kU'' = f(x), \quad U(a) = A, \quad U(b) = B.$$

The substitution $w(x, t) = u(x, t) - U(x)$ leads to the homogeneous problem

$$\begin{aligned}w_t - kw_{xx} &= 0, \quad a < x < b, \quad t > 0, \\w(a, t) &= 0, \quad w(b, t) = 0, \quad t > 0, \\u(x, 0) &= G(x) \equiv g(x) - U(x), \quad a < x < b.\end{aligned}$$

This problem may be solved using separation of variables. \square

Remark 4.30

It can be generally stated that if the heat equation has boundary conditions of the form

$$\alpha_1 u(0, t) + \alpha_2 u_x(0, t) = g_1(t), \quad \beta_1 u(l, t) + \beta_2 u_x(l, t) = g_2(t),$$

then the transformation

$$u = w + U(x, t) \equiv w + a(t) \left(1 - \frac{x}{l}\right) + b(t) \frac{x}{l}$$

where $a(t)$ and $b(t)$ are chosen so that $U(x, t)$ satisfies the boundary conditions, leads to a problem for w with homogeneous boundary conditions. The source term and initial condition may be altered. \square

Example 4.31

(Wave equation) Consider the nonhomogeneous wave equation

$$\begin{aligned} u_{tt} &= u_{xx} + Ax, & 0 < x < 1, & t > 0, \\ u(0, t) &= 0, \quad u(1, t) = 0, & t > 0, \\ u(x, 0) &= 0, \quad u_t(x, 0) = 0, & 0 < x < 1. \end{aligned}$$

Here there is an equilibrium solution $U = U(x)$ satisfying

$$-U'' = Ax, \quad U(0) = U(1) = 0.$$

It is easily found by integrating twice that $U(x) = \frac{A}{6}x(1-x^2)$. Then, $w(x, t) = u(x, t) - U(x)$ satisfies

$$\begin{aligned} w_{tt} &= w_{xx}, & 0 < x < 1, & t > 0, \\ w(0, t) &= 0, \quad w(1, t) = 0, & t > 0, \\ w(x, 0) &= -U(x), \quad w_t(x, 0) = 0, & 0 < x < 1. \end{aligned}$$

Now the problem can be solved using separation of variables. \square

Example 4.32

Consider the wave equation with nonhomogeneous boundary conditions:

$$\begin{aligned} u_{tt} &= u_{xx}, & 0 < x < l, & t > 0, \\ u(0, t) &= a(t), \quad u(l, t) = b(t), & t > 0, \\ u(x, 0) &= 0, \quad u_t(x, 0) = 0, & 0 < x < l. \end{aligned}$$

The reader can easily verify that the change of variables

$$w(x, t) = u(x, t) - \left(b(t) + \frac{b(t) - a(t)}{l} x \right)$$

leads to a problem with homogeneous boundary conditions for w . Nonhomogeneous terms are introduced in the resulting PDE and initial conditions. \square

EXERCISES

1. Use Duhamel's principle as formulated for the wave equation in Section 2.5 to find the solution to

$$\begin{aligned} u_{tt} - c^2 u_{xx} &= f(x, t), \quad 0 < x < \pi, \quad t > 0, \\ u(0, t) &= u(\pi, t) = 0, \quad t > 0, \\ u(x, 0) &= u_t(x, 0) = 0, \quad 0 < x < \pi. \end{aligned}$$

2. Use the eigenfunction method to solve the problem in Exercise 1. Hint: In the eigenfunction method you will have to solve a second-order nonhomogeneous ODE, which can be done using variation of parameters.
3. In the problem defined by (4.82–4.84) assume that the heat source does not depend on time, i.e., $f(x, t) = F(x)$. By calculating the τ -integral, show how the solution (4.85) simplifies in this case. Find a formula for the solution when the heat source is $F(x) = x(\pi - x)$ and then find the limiting temperature profile as $t \rightarrow \infty$. Show that this limiting temperature profile is the same as the steady-state solution, that is, the solution $v = v(x)$ to

$$-kv''(x) = x(\pi - x), \quad 0 < x < \pi; \quad v(0) = v(\pi) = 0.$$

4. Solve

$$\begin{aligned} u_t &= u_{xx}, \quad 0 < x < 1, \quad t > 0, \\ u(0, t) &= 0, \quad u(1, t) = A, \quad t > 0, \\ u(x, 0) &= \cos x, \quad 0 < x < 1. \end{aligned}$$

5. Solve

$$\begin{aligned} u_t &= u_{xx} + Q, \quad 0 < x < 1, \quad t > 0, \\ u(0, t) &= 0, \quad u(1, t) = 2u_0, \quad t > 0, \\ u(x, 0) &= u_0(1 - \cos \pi x), \quad 0 < x < 1. \end{aligned}$$

6. Transform the problem

$$\begin{aligned}u_t &= ku_{xx}, \quad 0 < x < 1, \quad t > 0, \\u(0, t) &= \cos t, \quad hu(1, t) + u_x(1, t) = 1, \quad t > 0, \\u(x, 0) &= \sin \pi x + x, \quad 0 < x < 1,\end{aligned}$$

into a problem with homogeneous boundary conditions. Give a physical interpretation of the boundary conditions.

7. Solve the problem

$$\begin{aligned}u_t &= ku_{xx} + \sin 3\pi x, \quad 0 < x < 1, \quad t > 0, \\u(0, t) &= u(1, t) = 0, \quad t > 0, \\u(x, 0) &= \sin \pi x, \quad 0 < x < 1.\end{aligned}$$

8. Solve the wave equation with a constant gravitational force:

$$\begin{aligned}u_{tt} &= c^2 u_{xx} - g, \quad 0 < x < 1, \quad t > 0, \\u(0, t) &= u(1, t) = 0, \quad t > 0, \\u(x, 0) &= u_t(x, 0) = 0, \quad 0 < x < 1.\end{aligned}$$

9. Solve

$$\begin{aligned}u_{tt} &= u_{xx} + q, \quad 0 < x < 1, \quad t > 0, \\u(0, t) &= 0, \quad u(1, t) = \sin t, \quad t > 0, \\u(x, 0) &= x(1 - x), \quad u_t(x, 0) = 0, \quad 0 < x < 1.\end{aligned}$$

10. Use Duhamel's principle to find a bounded solution to

$$\begin{aligned}u_t &= \Delta u + f(r, t), \quad 0 < r < R, \quad t > 0, \\u(R, t) &= 0, \quad t > 0, \\u(r, 0) &= 0, \quad 0 \leq r < R.\end{aligned}$$

11. Find the solution of the diffusion problem on a disk:

$$\begin{aligned}u_t &= \frac{1}{r} (ru_r)_r + f(r), \quad r < R, \quad t > 0, \\u(R, t) &= u_0, \quad t > 0, \\u(r, 0) &= g(r), \quad r < R.\end{aligned}$$

4.8 Poisson's Equation*

One of the fundamental equations in electrostatics and in steady heat flow is Poisson's equation with a Dirichlet boundary condition:

$$\begin{aligned}\Delta u &= u_{xx} + u_{yy} = f(x, y), & (x, y) \in \Omega, \\ u(x, y) &= 0, & (x, y) \in \partial\Omega.\end{aligned}$$

A basic result is that the nonhomogeneous source term $f(x, y)$ can be put into the boundary condition by changing the dependent variable; conversely, a nonhomogeneous boundary condition can be put into a source term in the PDE.

1. If $\Delta u = f$ on Ω and $u = g$ on $\partial\Omega$, let $u(x, y) = w(x, y) + v(x, y)$ where v is *any particular solution* of $\Delta v = f$. Then $\Delta u = \Delta w + \Delta v = f$. So, $\Delta w = 0$. On the boundary $\partial\Omega$, $u = w + v = g$, where v is the particular solution above. So $w = g - v$ on $\partial\Omega$. In summary,

$$\Delta w = 0 \text{ in } \Omega; \quad w = g - v \text{ on } \partial\Omega.$$

2. Let $\Delta u = f$ in Ω and $u = g$ on $\partial\Omega$. Let v be *any* function that satisfies the the boundary condition. Let $u(x, y) = w(x, y) + v(x, y)$ and $\Delta u = \Delta w + \Delta v = f$, or $\Delta w = f - \Delta v$. On the boundary $\partial\Omega$, we have $u = w + v$ or $g = w + g$. Thus

$$\Delta w = f - \Delta v \text{ in } \Omega; \quad w = 0 \text{ on } \partial\Omega.$$

In summary, this result states that *the Dirichlet problem for Poisson's equation can be solved if the Dirichlet problem for Laplace's equation can be solved.*

Example 4.33

For simple regions Ω , finding a particular solution is easy if $f(x, y)$ is a polynomial of degree n . Just assume a particular solution in the form of an $n + 2$ degree polynomial. For example, consider Poisson's equation $\Delta u = -2$ on a rectangle $0 < x < a$, $0 < y < b$, with zero Dirichlet boundary conditions. Take

$$v(x, y) = A + Bx + Cy + Dx^2 + Exy + Fy^2,$$

a second degree polynomial. Substituting into the PDE gives $2D + 2F = -2$ or $D + F = -1$. So choose $F = 0$ and $D = -1$. The other constants are arbitrary. Choose $B = a$. Then, $v(x, y) = ax - x^2$ is a particular solution. Therefore $\Delta w = 0$ in Ω and $w = -v(x, y)$ on $\partial\Omega$; in particular, $w(0, y) = w(a, y) = 0$ and

$w(x, 0) = w(x, b) = x^2 - ax$. This problem for w can be solved by separation of variables because it has homogeneous boundary conditions at $x = 0$ and $x = a$. \square

Example 4.34

On a disk of radius R , solve the boundary value problem

$$\begin{aligned}\Delta u &= 2, & 0 < r < R, \\ u(R, \theta) &= 0, & 0 \leq \theta \leq 2\pi.\end{aligned}$$

In polar coordinates, the PDE is

$$\frac{1}{r} \left(r u_r \right)_r + \frac{1}{r^2} u_{\theta\theta} = 2.$$

Because the boundary condition and source are independent of θ , this problem has a solution that depends only on r . By direct integration of the PDE,

$$u(r, \theta) = \frac{1}{2} r^2 + c_1 \ln r + c_2,$$

where c_1 and c_2 are arbitrary. Clearly $c_1 = 0$ by boundedness. Then $u(R, \theta) = 0$ forces $c_2 = -R^2/2$, giving

$$u(r, \theta) = \frac{1}{2} (r^2 - R^2). \quad \square$$

Eigenvalue Problems

A problem of great importance is to determine the eigenvalues of spatial differential operators on bounded domain.

Example 4.35

(Eigenvalues of the Laplacian) Consider the two-dimensional problem

$$-\Delta u = \lambda u, \quad \mathbf{x} \in \Omega, \tag{4.89}$$

$$u = 0, \quad \mathbf{x} \in \partial\Omega. \tag{4.90}$$

Generally, Ω is a two dimensional domain with boundaries along the coordinate directions. To find the **eigenvalues** λ we use separation of variables. The negative sign on the Laplacian gives positive eigenvalues. Specifically, we take $\Omega : 0 < x < \pi, 0 < y < \pi$. Then the PDE is $-(u_{xx} + u_{yy}) = \lambda u$ for $u = u(x, y)$. The Dirichlet boundary condition becomes $u(0, y) = u(\pi, y) = 0$ for $0 \leq y \leq \pi$, and $u(x, 0) = u(x, \pi) = 0$ for $0 \leq x \leq \pi$. We assume a separable solution of

the form $u(x, y) = X(x)Y(y)$ for some functions X and Y to be determined. Substituting gives

$$-X''(x)Y(y) - X(x)Y''(y) = \lambda X(x)Y(y),$$

which can be rewritten as

$$-\frac{X''(x)}{X(x)} = \frac{Y''(y) + \lambda Y(y)}{Y(y)},$$

with a function of x on one side and a function of y on the other. Therefore,

$$-\frac{X''(x)}{X(x)} = \frac{Y''(y) + \lambda Y(y)}{Y(y)} = \mu$$

for some separation constant μ . Hence, the PDE separates into two ODEs for the two spatial variables:

$$-X''(x) = \mu X(x), \quad -Y''(y) = (\lambda - \mu)Y(y).$$

Next we substitute the assumed form of u into the boundary conditions to obtain

$$X(0) = X(\pi) = 0 \text{ and } Y(0) = Y(\pi) = 0.$$

Consequently we have obtained two boundary value problems of Sturm–Liouville type,

$$\begin{aligned} -X''(x) &= \mu X(x), & X(0) &= X(\pi) = 0, \\ -Y''(y) &= (\lambda - \mu)Y(y), & Y(0) &= Y(\pi) = 0. \end{aligned}$$

The first problem has been solved earlier in this chapter and we have eigenpairs

$$X_n(x) = \sin nx, \quad \mu_n = n^2, \quad n = 1, 2, 3, \dots$$

Then the Y problem becomes

$$-Y''(y) = (\lambda - n^2)Y(y), \quad Y(0) = Y(\pi) = 0.$$

This problem is also of Sturm–Liouville type and will have nontrivial solutions $Y_k(y) = \sin ky$ when $\lambda - n^2 = k^2$, for $k = 1, 2, 3, \dots$. Therefore, double indexing λ , we get eigenvalues and eigenfunctions for the negative Laplacian with Dirichlet boundary conditions as

$$u_{n,k}(x, y) = \sin nx \sin ky, \quad \lambda_{n,k} = n^2 + k^2, \quad n, k = 1, 2, 3, \dots$$

Observe that there are infinitely many positive, real eigenvalues, whose limit is infinity, and the corresponding eigenfunctions are orthogonal, that is,

$$\int_{\Omega} (\sin nx \sin ky)(\sin mx \sin ly) dx dy = 0 \quad \text{if } n \neq m \text{ or } k \neq l. \quad \square$$

This example illustrates what to expect from the Dirichlet problem (4.89–4.90). In fact, the following properties hold, where we use the vector notation $\mathbf{x} = (x, y)$.

1. The eigenvalues are real.
2. There are infinitely many eigenvalues that can be ordered as $0 < \lambda_1 \leq \lambda_2 \leq \lambda_3 \leq \dots$ with $\lambda_n \rightarrow +\infty$ as $n \rightarrow \infty$.
3. Eigenfunctions corresponding to distinct eigenvalues are orthogonal with inner product $(u, v) = \int_{\Omega} u(\mathbf{x})v(\mathbf{x})d\mathbf{x}$.
4. The eigenfunctions $u_n(\mathbf{x})$ form a complete orthogonal set in the sense that any square-integrable function $f(\mathbf{x})$ on Ω can be uniquely represented in its generalized Fourier series

$$f(\mathbf{x}) = \sum_{n=1}^{\infty} c_n u_n(\mathbf{x}), \quad c_n = \frac{(f, u_n)}{\|u_n\|^2},$$

where the c_n are the Fourier coefficients, and the norm is $\|u_n\| = \sqrt{(u_n, u_n)}$. Convergence of the series is in the $L^2(\Omega)$ sense, meaning

$$\int_{\Omega} \left(f(\mathbf{x}) - \sum_{n=1}^N c_n u_n(\mathbf{x}) \right)^2 d\mathbf{x} \rightarrow 0 \quad \text{as } N \rightarrow \infty.$$

The results are exactly the same when the Dirichlet boundary condition (4.90) is replaced by a Neumann boundary condition $\frac{du}{dn} = 0$, with the exception that $\lambda = 0$ is also an eigenvalue, with eigenfunction $u_0(x) = \text{constant}$. When a Robin boundary condition $\frac{du}{dn} + a(\mathbf{x})u = 0$ is imposed, again there is a zero eigenvalue with constant eigenfunction provided $a(x) \geq 0$. If $a(x)$ fails to be nonnegative, then there may also be negative eigenvalues.

Remark 4.36

The previous results extend to the higher dimension Sturm–Liouville problem

$$-\text{div}(p \text{ grad } u) + qu = \lambda wu, \quad \mathbf{x} \in \Omega.$$

Here, $w = w(\mathbf{x}) > 0$, $p = p(\mathbf{x}) > 0$, $q = q(\mathbf{x})$, p , q and w are continuous on $\overline{\Omega}$, and p has continuous first partial derivatives on Ω . The boundary conditions may be Dirichlet ($u = 0$ on $\partial\Omega$) Neumann ($\frac{du}{dn} = 0$ on $\partial\Omega$), or Robin ($\frac{du}{dn} + a(\mathbf{x})u = 0$ on $\partial\Omega$, with $a(x) \geq 0$). In these cases the eigenfunctions u and v are orthogonal with respect to the inner product

$$(u, v)_w = \int_{\Omega} u(\mathbf{x})v(\mathbf{x})w(\mathbf{x}) d\mathbf{x},$$

and $\|u\|_w = \sqrt{(u, u)_w}$. The Fourier series takes the form

$$f(\mathbf{x}) = \sum_n c_n u_n(\mathbf{x}), \quad c_n = \frac{(f, u_n)_w}{\|u_n\|_w^2},$$

where convergence is

$$\int_{\Omega} \left(f(\mathbf{x}) - \sum_{n=1}^N c_n u_n(\mathbf{x}) \right)^2 w(\mathbf{x}) d\mathbf{x} \rightarrow 0 \quad \text{as } N \rightarrow \infty. \quad \square$$

Just as for one-dimensional Sturm–Liouville problems, the completeness of the set of eigenfunctions allows us to solve the nonhomogeneous problem.

Example 4.37

(Poisson’s equation) Consider the problem

$$-\Delta u = \rho(\mathbf{x}), \quad \mathbf{x} \in \Omega, \quad (4.91)$$

$$u(\mathbf{x}) = 0, \quad \mathbf{x} \in \partial\Omega. \quad (4.92)$$

This problem can be interpreted in either one, two, or three dimensions, and the weight function is 1. Let $\lambda_n, u_n(\mathbf{x}), n = 1, 2, 3, \dots$ be eigenvalue-eigenfunction pairs for the negative Laplacian, i.e.,

$$-\Delta u = \lambda u, \quad \mathbf{x} \in \Omega,$$

$$u(\mathbf{x}) = 0, \quad \mathbf{x} \in \partial\Omega.$$

Next, assume a solution to (4.91–4.92) of the form⁹

$$u(\mathbf{x}) = \sum c_n u_n(\mathbf{x}),$$

where the c_n are to be determined. Further, expand ρ in terms of the eigenfunctions as

$$\rho(\mathbf{x}) = \sum \rho_n u_n(\mathbf{x}), \quad \rho_n = \frac{(\rho, u_n)}{\|u_n\|^2}.$$

Substituting into the PDE (4.91) gives

$$-\Delta u = \sum -c_n \Delta u_n = \sum c_n \lambda_n u_n = \sum \rho_n u_n.$$

Therefore

$$c_n \lambda_n = \rho_n, \quad n = 1, 2, 3, \dots$$

⁹ All sums are over $n = 1, 2, 3, \dots$

If $\lambda_n \neq 0$ for all n , then

$$c_n = \frac{\rho_n}{\lambda_n}$$

for all n . Therefore, we have the solution representation

$$u(\mathbf{x}) = \sum \frac{\rho_n}{\lambda_n} u_n(\mathbf{x}).$$

It is instructive to write this as

$$\begin{aligned} u(\mathbf{x}) &= \sum \frac{\rho_n}{\lambda_n} u_n(\mathbf{x}) \\ &= \sum \frac{(\rho, u_n)}{\lambda_n \|u_n\|^2} u_n(\mathbf{x}) \\ &= \sum \frac{1}{\lambda_n \|u_n\|^2} \int_{\Omega} \rho(\mathbf{y}) u_n(\mathbf{y}) d\mathbf{y} u_n(\mathbf{x}) \\ &= \int_{\Omega} \left(\sum \frac{u_n(\mathbf{y}) u_n(\mathbf{x})}{\lambda_n \|u_n\|^2} \right) \rho(\mathbf{y}) d\mathbf{y}. \end{aligned}$$

If we define the **Green's function** by

$$G(\mathbf{x}, \mathbf{y}) = \sum \frac{u_n(\mathbf{y}) u_n(\mathbf{x})}{\lambda_n \|u_n\|^2},$$

Then the solution may be written simply as

$$u(\mathbf{x}) = \int_{\Omega} G(\mathbf{x}, \mathbf{y}) \rho(\mathbf{y}) d\mathbf{y}.$$

Thus, the solution is a weighted average of contributions at every point of the domain. A different interpretation is that the right side, an integral operator with kernel G , is the *inverse operator* of $-\Delta$ with a Dirichlet boundary condition. In other words the solution to $-\Delta u = \rho$ is $u = (-\Delta)^{-1} \rho$. \square

Example 4.38

(Neumann problem) If we consider the Neumann problem

$$\begin{aligned} -\Delta u &= \rho(\mathbf{x}), \quad \mathbf{x} \in \Omega, \\ \frac{du}{dn}(\mathbf{x}) &= 0, \quad \mathbf{x} \in \partial\Omega, \end{aligned}$$

then $\lambda_1 = 0$ is an eigenvalue of the negative Laplacian with nontrivial eigenfunction $u_1(x) = 1$. Then the same calculation as above repeats and we obtain

$$c_n \lambda_n = \rho_n, \quad n = 1, 2, 3, \dots$$

Now $\lambda_n \neq 0$ for all $n > 1$, and we get

$$c_n = \frac{\rho_n}{\lambda_n}, \quad n > 1.$$

However, in the case $\lambda_1 = 0$, we get $c_1 \cdot 0 = \rho_1$. If $\rho_1 \neq 0$, then this problem has no solution. However, if $\rho_1 = 0$, that is, $(\rho, u_1) = 0$, then c_1 is arbitrary. Therefore,

$$\begin{aligned} u(\mathbf{x}) &= c_1 + \sum_{n=2}^{\infty} \frac{\rho_n}{\lambda_n} u_n(\mathbf{x}) \\ &= c_1 + \int_{\Omega} \left(\sum_{n=2}^{\infty} \frac{u_n(\mathbf{y})u_n(\mathbf{x})}{\lambda_n \|u_n\|^2} \right) \rho(y) dy, \quad c_1 \text{ arbitrary.} \end{aligned}$$

In summary, if ρ is orthogonal to the eigenfunction $u_1(\mathbf{x}) = 1$, there are infinitely many solutions. If ρ is not orthogonal to $u_1(\mathbf{x}) = 1$, then there is no solution. \square

This latter result can be generalized as follows.

Theorem 4.39

(Fredholm alternative) Consider the boundary value problem

$$-\operatorname{div}(p(\mathbf{x}) \operatorname{grad} u) + q(\mathbf{x})u = \mu u + f(\mathbf{x}), \quad \mathbf{x} \in \Omega,$$

with homogeneous Dirichlet, Neumann, or Robin boundary conditions, where the coefficient functions satisfy the conditions in Remark 4.32, and f is a given function. Then,

- (a) If μ is not an eigenvalue of the corresponding homogeneous problem ($f = 0$), then there is a unique solution for all functions f with $\int_{\Omega} f(\mathbf{x}) d\mathbf{x} < \infty$.
- (b) If μ is an eigenvalue of the homogenous problem, then there is no solution or infinitely many solutions, depending upon the function f .

The proof of this theorem is straightforward and follows exactly the format of the proofs in Section 4.2, namely, to expand u and f in eigenfunction expansions and solve for the coefficients of u .

Green's Function for Infinite Domains

Solving Poisson's equation on bounded domains can, in theory, be done by the eigenfunction method discussed above. In practice, the domain must be simple for success. For infinite domains we illustrate a physical approach based

on point sources. Recall that (Section 2.1), for the heat equation, we found the solution to a problem with a unit, point source and then superimposed those solutions over a distribution of sources to obtain the solution to the Cauchy problem. For Poisson's equation we appeal to electrostatics in two dimensions. (Equally, one could think in terms of unit heat sources.) A unit positive charge placed at the origin induces an electric field whose potential is given by

$$U(x, y) = -\frac{1}{2\pi} \ln r, \quad r = \sqrt{x^2 + y^2}$$

which satisfies Laplace's equation. The potential is not defined at $(0, 0)$. The equipotential curves are clearly circles centered at the origin, and consistent with the fact that for a unit charge, the flux through an arbitrary circle C_r of radius r is

$$\text{flux} = \int_{C_r} \text{grad } u \cdot \mathbf{n} \, ds = \int_0^{2\pi} u_r r \, dr d\theta = 1.$$

By simple translation, the potential response at (x, y) caused by a unit point charge at any point (ξ, η) is

$$G(x, y, \xi, \eta) = -\frac{1}{2\pi} \ln \sqrt{(x - \xi)^2 + (y - \eta)^2}, \quad (4.93)$$

which is Green's function in \mathbb{R}^2 . Arguing exactly as for the heat equation, we can solve Poisson's equation

$$u_{xx} + u_{yy} = f(x, y), \quad (x, y) \in \mathbb{R}^2 \quad (4.94)$$

by treating the source term f as a distributed set of point sources at (ξ, η) of magnitude $f(\xi, \eta)$ for all ξ and η . By linearity we can superimpose these point source solutions $f(\xi, \eta)G(x, y, \xi, \eta)$ over all space to obtain

$$u(x, y) = \int_{\mathbb{R}^2} G(x, y, \xi, \eta) f(\xi, \eta) \, d\xi d\eta,$$

which is the solution to (4.94). Here, we assume that the source vanishes sufficiently rapid at infinity.

Example 4.40

(Green's function in upper-half plane) For infinite domains having boundaries with simple geometry, we can modify the Green's function above to derive a solution. Consider Poisson's equation in the upper-half plane:

$$u_{xx} + u_{yy} = f(x, y), \quad x \in \mathbb{R}, \quad y > 0, \quad (4.95)$$

$$u(x, 0) = 0, \quad x \in \mathbb{R}. \quad (4.96)$$

For a point charge, $G(x, y, \xi, \eta)$ the Green's function (4.93) does not satisfy the boundary condition at $y = 0$. So we introduce a negative point charge at the point $(\xi, -\eta)$ to counter the positive point charge at (ξ, η) . The Green's function for this *image charge* is $G(x, y, \xi, -\eta)$. See Figure 4.5. Therefore the net potential at an arbitrary point (x, y) in $y > 0$ is the sum of the two potentials from both charges, or

$$G(x, y, \xi, \eta) = -\frac{1}{2\pi} \ln R + \frac{1}{2\pi} \ln \bar{R} = \frac{1}{2\pi} \ln \frac{\bar{R}}{R},$$

where R and \bar{R} are the distances shown in the figure, which are easily calculated by the distance formula. Easily G satisfies the zero boundary condition at $y = 0$. Therefore, G is Green's function for the upper-half plane. Again, by superposition, the solution to (4.95–4.96) is

$$u(x, y) = \frac{1}{2\pi} \int_{y>0} \ln \left(\frac{\bar{R}}{R} \right) f(\xi, \eta) d\xi d\eta. \quad \square$$

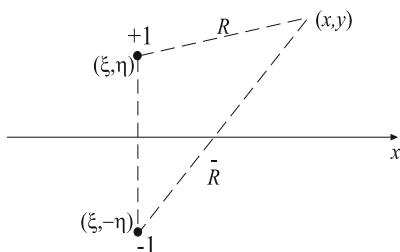

Figure 4.5 A unit (+1) charge placed at (ξ, η) and its negative image charge (−1) at $(\xi, -\eta)$. The distances between those charges and an arbitrary point (x, y) are R and \bar{R} , respectively, which are functions of x, y, ξ, η

The procedure in this example is called the **method of images**, and it can be applied for simple domains in both 2 and 3 dimensions. See Strauss (1992) or Haberman (2013), for example, for a thorough discussion of Green's functions.

EXERCISES

1. Solve the Dirichlet problem on a disk of radius $r = 2$:

$$u_{xx} + u_{yy} = 0, \quad x^2 + y^2 < 2, \quad u(x, y) = \sin \theta, \quad x^2 + y^2 = 2.$$

2. On a disk of radius R solve

$$\Delta u = -A \text{ in } 0 \leq r < R, \quad u = 1 \text{ on } r = R.$$

3. Solve the Poisson equation $\Delta u = 1$ on the unit disk with boundary condition $u(1, \theta) = \sin \theta$.
4. Solve $\Delta u = 1$ on the annulus $R_0 < r < R_1$ with $u = 0$ at $r = R_0, r = R_1$.
5. On the disk of radius R in the plane solve

$$\Delta u = f(r), \quad r < 1, \quad u = u_0, \quad r = R,$$

where u_0 is a constant.

6. Solve the boundary value problem

$$\begin{aligned} \Delta u &= f(r), \quad 0 < r < R, \quad 0 \leq \theta < 2\pi, \\ u(R, \theta) &= g(\theta), \quad 0 \leq \theta < 2\pi. \end{aligned}$$

7. In \mathbb{R}^2 find the eigenvalues and eigenfunctions of the Neumann problem

$$-\Delta u = \lambda u, \quad \mathbf{x} \in \Omega, \quad \frac{du}{dn} = 0, \quad \mathbf{x} \in \partial\Omega,$$

where Ω is the rectangle $0 < x < \pi, 0 < y < 1$.

8. Use the eigenfunction method to solve the Dirichlet problem for the Poisson equation:

$$\begin{aligned} u_{xx} + u_{yy} &= f(x, y), \quad 0 < x < \pi, \quad 0 < y < 1, \\ u(0, y) &= u(\pi, y) = 0, \quad 0 < y < 1, \\ u(x, 0) &= u(x, 1) = 0, \quad 0 < x < \pi. \end{aligned}$$

Hint: Assume $u(x, y) = \sum_{n=1}^{\infty} g_n(y) \sin nx$. Substitute into the PDE and boundary conditions at $y = 0$ and $y = 1$ to obtain

$$g_n''(y) - n^2 g_n(y) = f_n(y), \quad g_n(0) = g_n(1) = 0,$$

where $f_n(y) = \left(\frac{2}{\pi}\right) \int_0^\pi f(x, y) \sin nx \, dx$. Write the general solution in the form

$$g_n(y) = c_1 e^{ny} + c_2 e^{-ny} + \frac{2}{n} \int_0^y f_n(\xi) \sinh n(y - \xi) d\xi$$

and determine the constants c_1 and c_2 .

9. Consider Laplace's equation on a unit sphere.

- a) Assume a solution of the form $u(r, \theta, \phi) = S_n(\phi)r^n$, $n = 0, 1, 2, \dots$, and show that $S_n(\phi)$, the *spherical harmonics*, satisfies the equation

$$S_n'' + \frac{\cos \phi}{\sin \phi} S_n' + n(n+1)S_n = 0.$$

- b) Change the independent variable to $x = \cos \phi$ with $P_n(x) = S_n(\phi)$, and show

$$(1-x^2)P_n'' - 2xP_n' + n(n+1)P_n = 0.$$

This is **Legendre's differential equation**.

- c) Assume a power series solution of Legendre's equation of the form

$$P_n(x) = \sum_{k=0}^{\infty} a_k x^k,$$

and show that for each fixed n ,

$$a_{k+2} = \frac{k(k+1) - n(n+1)}{(k+2)(k+1)} a_k, \quad k = 0, 1, 2, \dots$$

- d) Show that for each fixed n , there is a polynomial solution. These are called the Legendre polynomials. Up to a constant multiple, find the first four Legendre polynomials $P_0(x), \dots, P_3(x)$. [Note: It can be shown that the Legendre polynomials are orthogonal on $-1 < x < 1$.]

10. Consider the partial differential operator

$$Lu = -\operatorname{div}(p \operatorname{grad} u) + qu, \quad \mathbf{x} \in \Omega,$$

where $p = p(\mathbf{x}) > 0$, $q = q(\mathbf{x})$, p and q are continuous on $\overline{\Omega}$, and p has continuous first partial derivatives on $\overline{\Omega}$.

- a) Prove the integration by parts formula

$$\int_{\Omega} vLu \, dx = \int_{\Omega} uLv \, dx + \int_{\partial\Omega} p \left(u \frac{dv}{dn} - v \frac{du}{dn} \right) dA.$$

- b) Consider the eigenvalue problem $Lu = \lambda u$, $\mathbf{x} \in \Omega$, with a Dirichlet boundary condition $u = 0$, $\mathbf{x} \in \partial\Omega$. Prove that the eigenvalues are positive and that distinct eigenvalues have corresponding orthogonal eigenfunctions.

11. Use the method of images to find the Green's function in the first quadrant of the plane, $x > 0$, $y > 0$, with zero conditions on the boundaries $x = y = 0$. Hint: Place appropriate image charges in the second and fourth quadrants.

-
12. Find Green's function $G(r, \theta, \rho, \phi)$ for the unit circle with zero boundary condition. Hint: Find the potential at (r, θ) due to unit source charge (ρ, ϕ) inside the circle. Place an image charge outside the circle at $(1/\rho, \phi)$.
 13. Show that Green's function for \mathbb{R}^3 is given by $G(\mathbf{x}, \mathbf{y}) = 1/4\pi R$, which is the potential at \mathbf{x} caused by a point source at \mathbf{y} , and $R = |\mathbf{x} - \mathbf{y}|$. Hint: Find the radial solution to Laplace's equation that has unit flux across any sphere containing the origin.

5

Applications in the Life Sciences

In Chapter 1 we introduced simple advection and diffusion models to describe the motion of organisms, cells, and chemicals in a biological science context. In this chapter we extend these ideas to more complicated phenomena involving age structure of a population, the propagation of epidemic waves, and the relationship between spatial pattern formation and chemical instability. These advanced models show why PDEs have vast applications in the life sciences. The mathematical methods we introduce to analyze these problems extend the ideas and techniques presented in the earlier chapters. For collateral reading, extensive applications of PDEs in biology can be found in Edelstein-Keshet (2005), Kot (2001), Britton (2003), and Murray (2003).

5.1 Age-Structured Models

By an **age-structured model** we mean a demographic model where the population at time t has an age distribution superimposed on it. Thus, at time t we also consider ages of the individuals. Age-structured models are akin to more general **physiologically-structured models** where any other variable, say size or weight, could replace age. For example, in many non-mammalian populations the evolution of the population, especially the mortality rate, certainly depends upon the size of the animals; the survival probability is small for young fish or insects. Our modeling focuses on age structure, but similar ideas apply to any physiological structure.

We begin by considering a population of female organisms whose age-structure at time $t = 0$ is given by $f(a)$. That is, $f(a)da$ is approximately the number of females between age a and $a + da$. Generally, we use females in demographic models because they have a well-defined beginning and end to their reproductive capacity. For simplicity, we write the age range as $0 \leq a < \infty$ even though the age of death is finite. Given the initial age structure, the mortality rate, and the fecundity rate (average number of offspring produced per female), the problem is to determine the age structure $u = u(a, t)$ at any time $t > 0$. Here, $u(a, t)da$ represents the number of females at time t between the ages a and $a + da$. Then the total female population at time t is

$$N(t) = \int_0^{\infty} u(a, t)da.$$

What makes this problem more intractable than other problems is that $u(0, t)$, which is the number of newborns at time t , is not known *a priori*. Rather, $u(0, t)$ depends upon the population and age of reproducing females, which is the unknown in the problem. Specifically, we assume that the *per capita mortality rate* is given as a function of age as $m = m(a)$. And we assume that the fecundity rate is $b(a, t)$, which depends upon both time and age of the female. Precisely, $b(a, t)$ is the average number of offspring per female of age a at time t ; the function $b(a, t)$ is called the *maternity function*. We expect $b(a, t)$ to be zero until the age of onset of maturity and zero after menopause. In between these ages the fecundity rate varies according to age; for example, in humans, women of age 25 are more fertile than women of age 40. Figure 5.1 depicts the evolution of age structure profiles in a three-dimensional atu -space (age-time-density space).

The governing dynamics is given by the equation

$$u_t = -u_a - m(a)u.$$

Thus, the model equation is the advection equation with speed one and sink term given by the mortality rate; notice that the flux is $\phi = u$, or the number crossing the age a line at time t is just $u(a, t)$, the density at that age. This continuous time model has its origins in the work of McKendrick in 1926 and in subsequent studies by von Forester in 1959. The equation is often called the **McKendrick–von Forester equation**. Now we formulate the boundary condition $u(0, t)$, the number of newborns at time t . Because $u(a, t)da$ is the number of females between a and $a + da$, and $b(a, t)$ is the average reproduction rate, the number of offspring produced by females between age a and age $a + da$ is $b(a, t)u(a, t)da$. Thus, the total number of offspring produced by all females is the (sum) integral over all ages, or

$$u(0, t) = \int_0^{\infty} b(a, t)u(a, t)da.$$

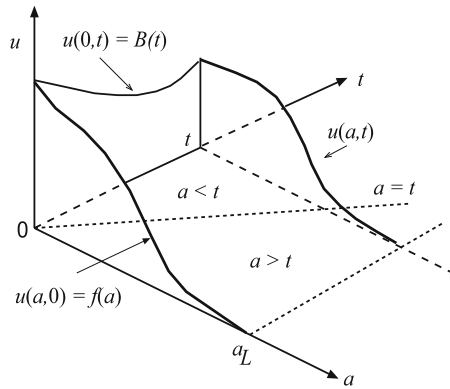

Figure 5.1 Age-structured model: $f(a)$ is the initial, known age structure, and $u(0, t) = B(t)$ is the unknown offspring at age $a = 0$ and time t . The age structure $u(a, t)$ for $a > t$ is affected only by the initial population $f(a)$, whereas for $a < t$ it is affected by the entire population and its fecundity; a_L is the maximum lifetime age. Individuals follow paths, or characteristics, $a = t + \text{constant}$ in age-time space

Therefore we have derived the age-structured model

$$u_t = -u_a - m(a)u, \quad a > 0, \quad t > 0, \tag{5.1}$$

$$u(0, t) = \int_0^\infty b(a, t)u(a, t)da, \quad t > 0, \tag{5.2}$$

$$u(a, 0) = f(a), \quad a \geq 0. \tag{5.3}$$

We emphasize again that the left boundary condition at age $a = 0$ is not known, but rather depends upon the solution $u(a, t)$, which is also unknown. This type of condition is called a **nonlocal boundary condition** because it depends upon the integrated unknown solution in the problem.

Age-structured models may be visualized as a conveyor belt of age length $0 \leq a \leq a_L$ moving at speed one year, per year. Individuals, representing a cohort, enter at age $a = 0$ and move forward along the belt in time. As they progress they are subject to mortality, and they reproduce between the ages of fertility, $a_m < a < a_M$. Those newborns then enter the belt at age $a = 0$.

Stable Age Structure

Rather than attempting to solve (5.1–5.3) directly, we take a different tack common in demographic models. We ignore the initial condition (5.3) and ask what happens over a long time. Births from the initial population $f(a)$ only

affect the solution for a finite time because those individuals and their offspring die. Therefore, in the case that the maternity function is independent of time, i.e., $b = b(a)$, we look for a **stable age structure** of the form

$$u(a, t) = U(a)e^{rt}, \quad t \text{ large}$$

where $U(a)$ is an unknown age structure and r is an unknown growth rate. Substituting into the PDE (5.1) and making reductions gives an ODE for $U(a)$,

$$U'(a) = -(m(a) + r)U(a).$$

This equation can be solved by separation of variables to get

$$U(a) = Ce^{-ra}e^{-\int_0^a m(s)ds},$$

where C is a constant. Letting $S(a) = \exp\left(-\int_0^a m(s)ds\right)$ denote the *survivorship function*, which is the probability of surviving to age a , we can write the long time solution as

$$u(a, t) = Ce^{rt-ra}S(a). \quad (5.4)$$

To determine the growth constant r , we substitute (5.4) into the nonlocal boundary condition (5.2) to obtain

$$1 = \int_0^\infty b(a)e^{-ra}S(a)da, \quad (5.5)$$

which is the **Euler–Lotka equation**. Using numerical methods this equation can be solved for r , and we will have determined, up to a constant, the long-time age structure $U(a)$ of the population and its growth rate r .

In the special case $m = \text{constant}$, the Euler–Lotka equation is

$$1 = \int_0^\infty b(a)e^{-(r+m)a}da.$$

This equation determines the growth rate r of the population. The exercises request calculations for specific population data.

The Renewal Equation

The method of characteristics introduced in Section 1.2 may be used to study (5.1–5.3) in the simple case when $b = b(a)$ and $m = \text{constant}$. The PDE (5.1) is

$$u_t = -u_a - mu, \quad a > 0, \quad t > 0. \quad (5.6)$$

If we change independent variables via the formulae

$$\xi = a - t, \quad \tau = t,$$

then the PDE (5.6) becomes

$$U_\tau = -mU, \quad \text{where } U = U(\xi, t).$$

This equation has general solution

$$U(\xi, \tau) = C(\xi)e^{-m\tau},$$

where C is an arbitrary function. In terms of the original variables,

$$u(a, t) = C(a - t)e^{-mt}.$$

To determine the arbitrary function C we consider two cases, $a > t$ and $a < t$. See Figure 5.1. The arbitrary function is different in each case. The solution in $a > t$ is determined by the initial age structure and we have

$$u(a, 0) = C(a) = f(a).$$

Therefore

$$u(a, t) = f(a - t)e^{-mt}, \quad a > t. \quad (5.7)$$

For $a < t$ we denote, for simplicity, $B(t) = u(0, t)$. Then, applying the boundary condition gives

$$u(0, t) = B(t) = C(-t)e^{-mt},$$

or

$$C(s) = B(-s)e^{-ms}.$$

Consequently

$$u(a, t) = B(t - a)e^{-ma}, \quad a < t. \quad (5.8)$$

The solution to (5.1–5.3) in the case $m(a) = m$ and $b(a, t) = b(a)$ is given by (5.7–5.8), but B is still unknown. To find B we substitute the expressions (5.7–5.8) into the yet unused nonlocal boundary condition (5.2). After breaking up the integral into two age domains, we obtain

$$\begin{aligned} B(t) &= \int_0^\infty b(a)u(a, t)da \\ &= \int_0^t b(a)u(a, t)da + \int_t^\infty b(a)u(a, t)da, \end{aligned}$$

or

$$B(t) = \int_0^t b(a)B(t - a)e^{-ma}da + \int_t^\infty b(a)f(a - t)e^{-mt}da. \quad (5.9)$$

Equation (5.9) is a *linear integral equation* for the unknown $B(t)$, and it is called the **renewal equation**. Once it is solved for $B(t)$, then (5.7–5.8) give the age structure for the population. In Exercise 2 the reader is asked to solve the renewal equation in a special case. Generally, (5.9), a nonhomogeneous

Volterra equation, is difficult to solve and must be dealt with numerically, or by successive approximation (iteration).

Structured Predator–Prey Model

The previous discussion illustrates how age structure leads to an advection equation that can be solved, in theory, by standard change of variable methods. Now we consider a more difficult nonlinear predator-prey problem where a different technique is illustrated. The method is called the **method of moments**, which is akin to an energy method. We can add this important technique to our analytic tool bag for dealing with PDEs.

We consider a population of prey with age density $u(a, t)$ and constant *per capita* mortality rate m . Then, as above, the governing age-time dynamics is given by

$$u_t = -u_a - mu, \quad a > 0, \quad t > 0, \quad (5.10)$$

where the initial number of prey is

$$u(a, 0) = f(a). \quad (5.11)$$

The total prey population is

$$N(t) = \int_0^\infty u(a, t) da.$$

We assume that the maternity function is

$$b(a) = b_0 a e^{-\gamma a}.$$

Then the prey produce offspring (eggs) given by

$$B(t) = \int_0^\infty b_0 a e^{-\gamma a} u(a, t) da.$$

Now let us introduce a total predator population $P = P(t)$; we shall not consider age-structure in the predator population, but only that the predators eat the eggs of the prey. (To stimulate thinking about this model, remember one of the theories posed for the extinction of the dinosaurs is that egg-eating predators caused the demise). Because predators eat only eggs ($a = 0$), the PDE is unaffected. What is affected is the actual number of offspring $u(0, t)$ produced. Thus we no longer have $u(0, t) = B(t)$, but rather we must include a predation term that decreases the egg population. The simplest model is the Lotka–Volterra model, which requires that the number eggs eaten is proportional to the product of the number of eggs and the number of predators. That is, we have

$$u(0, t) = B(t) - kB(t)P(t),$$

where k is a proportionality constant. But the right side can be negative, so we define $M(B, P) = \max(B - kBP, 0)$ and take the number of eggs at $a = 0$ to be

$$u(0, t) = M(B, P). \quad (5.12)$$

This equation provides the boundary condition to the problem. Finally, we ask how the predator population changes. We assume Lotka–Volterra dynamics

$$\frac{dP}{dt} = -\delta P + cBP, \quad (5.13)$$

where δ is the per capita mortality rate and c is the yield. Hence, in the absence of eggs, predators die out. Initially, we take $P(0) = P_0$.

We remark that if the predators consumed prey other than eggs, then a predation term would have to be included as a sink term on the right side of the dynamical equation (5.10).

The method of moments allows us to obtain a system of ordinary differential equations for the total prey and predator populations $N(t)$ and $P(t)$. In the analysis, we will also obtain equations for some additional auxiliary variables, but the overall end result is a system of ODEs, which is simpler than the mixed PDE-ODE system given by the model equations (5.10–5.13).

The idea is to multiply the PDE (5.10) by a *moment* function $g(a)$ and then integrate over $0 \leq a \leq \infty$. The only requirement is that $u(a, t)g(a) \rightarrow 0$ as $a \rightarrow \infty$. Upon taking g to be different functions, we can obtain equations that lead to the differential equations we seek. The reader will find it valuable to verify these calculations. Proceeding in a general way, we multiply the PDE by g and integrate to get

$$\frac{d}{dt} \int_0^\infty g(a)u(a, t)da = - \int_0^\infty g(a)u_a(a, t)da - m \int_0^\infty g(a)u(a, t)da.$$

The first integral on the right can be integrated by parts to get

$$\frac{d}{dt} \int_0^\infty g(a)u(a, t)da = M(B, P)g(0) + \int_0^\infty g'(a)u(a, t)da - m \int_0^\infty g(a)u(a, t)da. \quad (5.14)$$

Now we make different choices for g . If $g(a) = 1$ then (5.14) becomes simply

$$\frac{dN}{dt} = M(B, P) - mN, \quad (5.15)$$

an ODE involving N, P , and B . If we take $g(a) = b(a)$, the maternity function, then (5.14) becomes

$$\frac{dB}{dt} = -\gamma B + b_0H - mB, \quad (5.16)$$

where $H = H(t)$ is defined by

$$H(t) = \int_0^\infty e^{-\gamma a} u(a, t) da.$$

But now H is yet a new variable. To get another equation involving H we take $g(a) = e^{-\gamma a}$. Then (5.14) becomes

$$\frac{dH}{dt} = M(B, P) - (m + \gamma)H. \quad (5.17)$$

Therefore we have four ODEs (5.13), (5.15–5.17) for N , P , B , and H . Clearly the N equation decouples from the system and we can just consider the three ODEs

$$\frac{dP}{dt} = -\delta P + cBP, \quad \frac{dB}{dt} = -(m + \gamma)B + b_0H, \quad \frac{dH}{dt} = M(B, P) - (m + \gamma)H.$$

The initial conditions are $P(0) = P_0$, $B(0) = \int_0^\infty b_0 a e^{-\gamma a} f(a) da$, $H(0) = \int_0^\infty e^{-\gamma a} f(a) da$.

We can now proceed with a numerical method (e.g., the Runge–Kutta method) to solve the system and determine the dynamics. The reader is asked for such a calculation in Exercise 4.

EXERCISES

1. Consider a population of organisms whose *per capita* death rate is three percent per month and that the maternity function, in births per female per age in months, is given by $b(a) = 4$ for $3 \leq a \leq 8$, and $b(a) = 0$ otherwise. Use the Euler–Lotka equation to calculate the growth rate r .
2. Consider the age-structured model (5.1–5.3) in the case that the mortality rate is constant ($m(a) = \gamma$) and the maternity function is a constant ($b(a, t) = \beta$). At time $t = 0$ assume the age distribution is $f(a) = u_0$ for $0 < a \leq \delta$, and $f(a) = 0$ for $a > \delta$.

(a) Show that the renewal equation (5.9) takes the form

$$B(t) = \int_0^t \beta B(s) e^{-\gamma(t-s)} ds + \beta \delta u_0 e^{-\gamma t}.$$

(b) Show that $B(t)$ satisfies the differential equation

$$B' = (\beta - \gamma)B.$$

Hint: use Leibniz' rule to differentiate the integral.

(c) Determine $B(t)$ and the population density $u(a, t)$.

(d) What is the total size $N(t)$ of the population at any time t ?

3. Consider the structured model where the per capita mortality rate depends upon the total population $N = N(t)$ and the maternity function is $b(a) = b_0 e^{-\gamma a}$:

$$\begin{aligned} u_t &= -u_a - m(N)u, \quad a > 0, t > 0, \\ u(0, t) &= \int_0^\infty b_0 e^{-\gamma a} u(a, t) da, \\ u(a, 0) &= f(a), \quad a > 0. \end{aligned}$$

- (a) Use the method of moments to obtain the system of ODEs

$$\frac{dN}{dt} = B - m(N)N, \quad \frac{dB}{dt} = (b_0 - \gamma - m(N))B,$$

for $N(t)$ and the offspring $B(t) = u(0, t)$. (Note that the maternity function in this model is unreasonable because it predicts that newborns give birth; but it may be a good approximation when the females reproduce at a very young age).

- (b) Show that the relation $B = (b_0 - \gamma)N$ gives a solution to the ODEs in the NB -plane.
- (c) Show that the solution to the system cannot oscillate and, in fact, approaches a steady state.
4. Numerically solve equations (5.13), (5.15–5.17) and plot the prey and predator populations $N(t)$ and $P(t)$ for $0 \leq t \leq 125$. Take $b_0 = 5$ and the remaining constants to be one. Based upon your calculation, is there a basis for controlling pests by introducing predators that selectively eat their eggs?
5. Consider an age-structured population where $u = u(a, t)$ is the age density of people at age a at time t . In a model where no person survives past age $a = d$, the PDE for u is given by

$$u_t + u_a = -\frac{c}{d-a}u, \quad 0 < a < d, t > 0.$$

Interpret this model and use the methods in Chapter 1, or otherwise, to find the general solution. Then use analytical techniques to find the solution that satisfies the initial and boundary conditions

$$u(a, 0) = f(a), \quad 0 \leq a \leq d; \quad u(0, t) = B(t), \quad t > 0,$$

where $f(a)$ is the initial age structure and $B(t)$ is a given birth schedule.

6. This exercise presents an alternate derivation of the McKendrick-von Forester equation (5.1). If $u(a, t)$ is the density of females of age a at time t , then at a small time dt later, all females still alive will have aged an amount $da = dt$. Thus, the average number of females dying in this interval is

$$\frac{u(a + da, t + dt) - u(a, t)}{dt} = -m(a)u(a, t) + O(dt),$$

where $m(a)u(a, t)dt$ represents the probability of dying in the small time interval t to $t + dt$. Finish the derivation.

5.2 Traveling Waves Fronts

We observed in Chapter 1 that the advection equation $u_t = -cu_x$ and the wave equation $u_{tt} = c^2u_{xx}$ both admit **traveling wave solutions** of the form $u(x, t) = U(z)$, where U is any function (the shape of the wave), and $z = x - ct$ is a moving coordinate that travels with speed c . As it turns out, many nonlinear PDEs have these types of solutions. They model a signal, or disturbance, that moves with constant speed, and they can represent moving population fronts, infectious disease or epidemic waves, biological invasions, chemical reaction fronts, and many other interesting biological phenomena.

First consider the model diffusion-type equation having the general form

$$u_t = Du_{xx} + f(u, u_x), \quad (5.18)$$

where f is some fixed function, possibly nonlinear, depending the concentration u and its spatial gradient u_x . We are interested in finding solutions of the form $u(x, t) = U(z)$, where $z = x - ct$, where both the wave form U and the wave speed c are unknown. The spatial independent variable x is assumed to vary over all real numbers, that is, $-\infty < x < \infty$, and therefore $-\infty < z < \infty$. We can find an equation for the shape of the wave $U(z)$ by substituting this form into the PDE. First, we calculate the partial derivatives of u in order to make the substitution. Using the multi-variable chain rule, we get

$$\begin{aligned} u_t &= U'(z)z_t = -cU'(z), \\ u_x &= U'(z)z_x = U'(z), \\ u_{xx} &= U''(z)z_x = U''(z). \end{aligned}$$

Substituting into the PDE produces an ODE for the wave form $U(z)$:

$$-cU' = DU'' + f(U, U'), \quad -\infty < z < \infty. \quad (5.19)$$

Notice that the ODE has only two variables, the independent “moving” coordinate z and the dependent wave form U . The variables t and x dropped out of the problem, which is required if the method is to succeed. The constant wave speed is not known.

Ordinary differential equations are sometimes easier to deal with than PDEs. In the present case we have a second-order ODE where the independent variable is any real number. Solutions of such equations usually depend upon two arbitrary constants, and we need two auxiliary conditions to determine those constants. Therefore we impose conditions at $z = \pm\infty$ on the wave form, namely that $U(z)$ approach constant values, or densities, at both extremes:

$$U(-\infty) = u_l, \quad U(+\infty) = u_r, \quad (5.20)$$

where u_l and u_r are two fixed constants. We assume these two states are equilibrium states for the equation, i.e., $f(u_l, 0) = f(u_r, 0) = 0$. Thus we are not interested in any traveling wave, but only those that are bounded and approach constant, equilibrium states at $z = \pm\infty$. These special types of traveling wave solutions are called **wave front solutions**. See Figure 5.2.

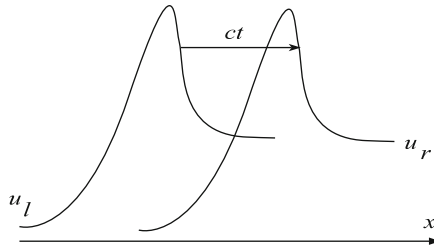

Figure 5.2 Plot of two successive wave profiles of a right, traveling wave front solution moving at speed c

To complicate matters, the wave speed c is also unknown and often acts as an *eigenvalue*; that is, wave front solutions will exist only for certain values of c . Hence, we often refer to (5.19–5.20) as a nonlinear eigenvalue problem.

Wave fronts can arise from natural settings as limiting, or long time, solutions to boundary value problems. As an illustration, consider the initial BVP for a toxic chemical of concentration $u = u(x, t)$ in a semi-infinite domain, e.g.,

a long canal:

$$\begin{aligned}u_t &= Du_{xx} + f(u, u_x), \quad x > 0, \quad t > 0, \\u(x, 0) &= 0, \quad x > 0, \\u(0, t) &= 1, \quad t > 0, \\u(\infty, t) &= 0.\end{aligned}$$

Here f is a term that contains advection and reaction processes. Intuitively, we reason as follows. For early times a concentration wave with unit magnitude at the left boundary ($x = 0$) begins to move into the medium; at these times the shape of the wave changes as it evolves. However, over a longer time the concentration wave can begin to approach a wave front with the same shape wave form. That is, the solution to the initial BVP may approach a wave front having the form $u = F(x - ct)$ for some wave speed c . Often we just look for the wave front. The issue of whether solutions to initial BVPs evolve into wave fronts is a question of whether the wave front attracts other solutions, i.e., it is one of stability of the front.

Generally we cannot find an explicit solution to (5.19) and we resort to numerical computation. Oftentimes we can prove there must be a unique solution without solving the equation in any manner. A standard technique is to transform (5.19) to a system of first order ODEs for the variables U and $V = U'$ in the UV phase plane. We obtain

$$\begin{aligned}U' &= V, \\V' &= -\frac{c}{D}V - \frac{1}{D}f(U, V).\end{aligned}$$

Assuming that V , or equivalently U' , goes to zero at $z = \pm\infty$, the problem of finding a wave front solution to (5.19) now consists of finding a solution (trajectory) in phase space that connects the two equilibrium points $(u_l, 0)$ and $(u_r, 0)$. A thorough discussion of the phase space method is beyond our scope and we refer the reader to other sources (e.g., Logan 2001, 2009, or the references given at the beginning of this chapter).

Example 5.1

Consider the diffusion equation

$$u_t = Du_{xx}.$$

Solutions of the form $u(x, t) = U(z)$, where $z = x - ct$, must satisfy the ODE

$$-cU' = DU''.$$

This is a linear second-order equation with characteristic equation $-cm = Dm^2$ having roots $m = 0$, $m = -c/D$. Therefore the independent solutions are 1 and $e^{-cz/D}$, and the general solution is therefore

$$U(z) = c_1 + c_2 e^{-cz/D},$$

or

$$u(x, t) = c_1 + c_2 e^{-c(x-ct)/D}.$$

Therefore the diffusion equation admits traveling wave solutions, but not (non-constant) wave front solutions because $e^{-cz/D}$ does not remain bounded at $z = +\infty$. \square

Example 5.2

(Epidemic waves) We consider a model for the spread of a rabies epidemic throughout a healthy population of foxes. We set up the problem in one-dimensional linear geometry, and we ignore natural mortality and births. Let $S = S(x, t)$ denote the density of the susceptible fox population and $I = I(x, t)$ the density of the infected foxes. We assume the rate that healthy foxes become infected is proportional to SI , the argument being that the number of contacts between members of the two groups is equal to their product; thus the rate of conversion of susceptibles to infecteds is bSI , where b is the constant infection rate, or the fraction of the contacts that lead to infection. Because rabies is fatal, we assume that infected foxes die at *per capita* rate r and they are removed from the susceptible and infected populations. Finally, we assume that healthy foxes are territorial and do not diffuse, while rabid foxes are disoriented and diffuse randomly with diffusion constant D . Thus we have the model equations

$$\begin{aligned} S_t &= -bSI, \\ I_t &= bSI - rI + DI_{xx}. \end{aligned}$$

By an epidemic wave we mean a wave of infecteds moving into a healthy population, and we model it by a wave front of unknown wave speed c . Letting $S = S(z)$, $I = I(z)$, $z = x - ct$, we get wave front equations

$$\begin{aligned} -cS' &= -bSI, \\ -cI' &= bSI - rI + DI''. \end{aligned}$$

At $z = +\infty$, ahead of the infection or epidemic wave, we assume there are only susceptibles, so $S(+\infty) = N$, where N is the total population of foxes, and $I(+\infty) = 0$. After the wave has passed, at $z = -\infty$, we assume no infecteds remain, or $I(-\infty) = 0$ (the epidemic has died out), and the number of susceptibles is $S(-\infty) = S_l$, which is not known *a priori*. We want to determine the

speed c of the epidemic wave and S_l , the number that will not get the disease. Figure 5.3 shows the shapes of the waves that we might expect.

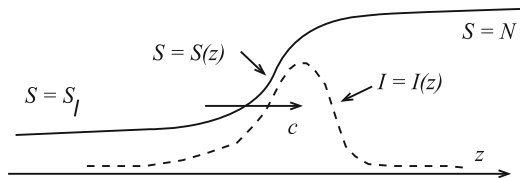

Figure 5.3 SI epidemic wave $S = S(x - ct)$

To make progress, note that $S'/S = (\ln S)'$, so the first equation becomes $I = (c/b)(\ln S)'$. We can substitute this into the second equation to obtain

$$-cI' = cS' - \frac{rc}{b}(\ln S)' + DI'',$$

which can be integrated with respect to z since every term is a derivative. Then

$$-cI = cS - \frac{rc}{b} \ln S + DI' + a,$$

where a is a constant of integration. Taking the limit as $z \rightarrow +\infty$ gives $a = c\left(\frac{r}{b} \ln N - N\right)$. Taking the limit as $z \rightarrow -\infty$ gives another equation relating a and c , namely $a = c\left(\frac{r}{b} \ln S_l - S_l\right)$. Therefore

$$\frac{r}{b} \ln N - N = \frac{r}{b} \ln S_l - S_l, \quad (5.21)$$

which is a relation between the number S_l that do not get the disease, the total initial population N , the infection rate b , and the death rate r . The relation is independent of the epidemic wave speed c . To simplify, we introduce parameters

$$R_0 = \frac{r}{Nb}, \quad F = \frac{S_l}{N},$$

where F is the fraction that do not contract rabies and R_0 is the reproductive ratio of the disease, representing the death rate divided by the infection rate. Then (5.21) can be written in the form

$$R_0 = \frac{F - 1}{\ln F}, \quad 0 < F < 1.$$

A plot of this function is shown in Figure 5.4, from which we infer that R_0 cannot exceed 1. Thus, no epidemic wave front can occur when $R_0 > 1$. This is reasonable since the death rate would be high compared to the rate of getting the disease; the epidemic dies out because the infecteds die out faster than they

are replaced. This case can occur if b is small or can be forced small, say, by inoculation. On the other hand, if $R_0 < 1$ then an epidemic wave can propagate; the smaller R_0 , the greater the number that get rabies. \square

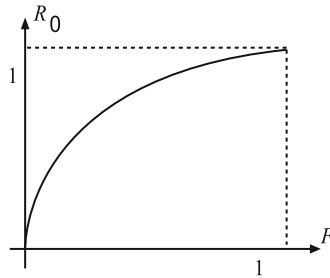

Figure 5.4 Plot of F vs R_0

Several questions remain in this example. We did not solve the wave front equations to find the wave forms or even show that such wave forms exist; nor did we determine the speed of the epidemic. The goal has been to derive certain properties of the epidemic wave under the assumption that it exists. A more thorough analysis, given in the references, shows that such solutions do exist.

EXERCISES

1. Show that the nonlinear advection-diffusion equation

$$u_t = Du_{xx} - uu_x$$

admits a wave front solution $U = U(z)$, satisfying the boundary conditions $U(-\infty) = 1$, $U(+\infty) = 0$. Find the wave speed and sketch the solution on a zu -coordinate system if $U(0) = \frac{1}{2}$.

2. Consider a reaction-diffusion equation with a nonlinear advection term given by

$$u_t = u_{xx} - u^2 u_x.$$

For which wave speeds c does a positive wave front solution exist with $u \rightarrow 0$ as $x \rightarrow \infty$? What are the possible states at $x = -\infty$?

3. Consider the system of reaction-advection-diffusion equations

$$\begin{aligned}u_t &= Du_{xx} - \gamma u_x - aF(u, v), \\v_t &= -bF(u, v),\end{aligned}$$

where a , b , D , and γ are positive constants. Find a system of ODEs for traveling wave forms $u = U(z)$, $v = V(z)$, $z = x - ct$. If boundary conditions are given by

$$U(-\infty) = u_l, \quad U(+\infty) = 0, \quad V(-\infty) = 0, \quad V(+\infty) = v_r,$$

what conditions must the reaction term F satisfy for wave front solutions to exist? Sketch possible wave front profiles. Assuming wave fronts exist, show that the speed c of the wave is less than the advection speed γ .

4. The following system of PDEs arises in the study of bioremediation of aquifer systems where immobile, indigenous microbes attached to the soil are stimulated to consume a contaminant and produce nontoxic products (see Logan 2001, p. 107):

$$RS_t = -vS_x - F, \quad A_t = -vA_x - rF, \quad M_t = yF - b(M - M_0),$$

where $M(x, t)$ is the density of the microbes, $S(x, t)$ is the density of the contaminant (e.g., a hydrocarbon), $A(x, t)$ is the density of a nutrient stimulant (e.g., oxygen), and $F = qSAM / \left[(K_s + S)(K_a + A) \right]$ is the biodegradation rate. $R > 1$ is the retardation constant, v is the average velocity of the subsurface flow, b is the decay rate of the bacteria, y is the yield, M_0 is a reference microbe density, and r is the mass of the nutrient used per mass contaminant degraded; q , K_s , and K_a are rate constants. Find the speed c of an assumed wave front that satisfies the boundary conditions $S = 0$, $A = A_0$ at $-\infty$, $S = S_r$, $A = 0$ at $+\infty$, and $M = M_0$ at $\pm\infty$. Without solving the wave front differential equations, sketch anticipated profiles of S , A , and M as a function of the variable $z = x - ct$.

5. The nonlinear PDE model

$$\left((1 + b)u - mu^2 \right)_t = u_{xx} - u_x$$

arises in the subsurface transport of a contaminant that is adsorbed to the soil. Assume $b > m$. Find a wave front solution $u = U(x - ct)$ satisfying the conditions $U(-\infty) = 1$, $U(+\infty) = 0$, $U(0) = 0.5$. The solution is

$$u(x, t) = \frac{1}{1 + e^{cm(x-ct)}}.$$

5.3 Equilibria and Stability

We already noted the broad occurrence of diffusion problems in biological systems. Now we investigate another aspect of such problems, namely the persistence of equilibrium states in systems governed by reaction-diffusion systems. At issue is the stability of those states: if a system is in an equilibrium state and it is slightly perturbed, or displaced, does the system return to that state, or does it evolve to a completely different state?

Underpinned by the seminal work of Alan Turing in 1952 on the chemical basis of morphogenesis, it has been shown in extensive research that diffusion induced instabilities can give rise to spatial patterns in all sorts of biological systems. Reaction-diffusion models have been used to explain the evolution of form and structure in developmental biology (morphogenesis), tumor growth, ecological spatial patterns, aggregation, patterns on animal coats, and many other processes in molecular and cellular biology.

In this section we introduce the basic idea of stability in reaction-diffusion models and we observe that such systems can have instabilities that lead to density variations and patterns. We refer the reader to Murray (2003) for an in-depth treatment of these models in the life sciences.

Stability

To illustrate the notion of stability of an equilibrium, or steady-state, to a PDE, we begin with a review of the stability issue for ODEs. For example, consider the logistics population model

$$\frac{du(t)}{dt} = ru(t) \left(1 - \frac{u(t)}{K} \right), \quad (5.22)$$

where r is the intrinsic growth rate and K is the carrying capacity, both positive. A steady-state, or *equilibrium solution*, is a constant solution $u = u_e$. For such a solution the left side of (5.22) must be zero, and so u_e satisfies the algebraic equation

$$ru_e \left(1 - \frac{u_e}{K} \right) = 0.$$

Therefore there are two equilibria, $u_e = 0$ and $u_e = K$. If at some time t the system is in an equilibrium state, it remains in that state for all time. That, if $u(t_0) = u_e$ for some t_0 , then $u(t) = u_e$ for all $t > t_0$ because $u(t) = u_e$ satisfies both the initial condition and the differential equation; uniqueness implies this. Natural “perturbations,” however, often disturb equilibrium and move the system a small amount away from its steady state. Does the system return to that state, or does it deviate significantly from that state, possible going to another equilibrium state? This is the question of stability. In the

present example, if the system is at carrying capacity $u = K$ and a small number of organisms are removed, does the system grow back to that original state or does it do something else? To answer this question we try to determine how a small deviation, or *perturbation*, will evolve by finding an equation for the deviation and solving it. Therefore, let $U(t)$ be a *small deviation* from the steady state $u = K$. That is, assume $u(t) = K + U(t)$. Then $u(t)$ must still solve the model equation. Substituting into (5.22) gives

$$\frac{d(K + U(t))}{dt} = r(K + U(t)) \left(1 - \frac{K + U(t)}{K} \right).$$

Simplifying the right side and noticing that $dK/dt = 0$ gives

$$\frac{dU(t)}{dt} = -\frac{r}{K} (KU(t) + U(t)^2), \quad (5.23)$$

which is called the **perturbation equation**. In general we cannot always solve the perturbation equation, so we make another argument. In (5.23) the perturbation $U(t)$ is small; therefore the $U(t)^2$ term is very small compared to the $U(t)$ term and we can discard it to obtain a **linearized perturbation equation**

$$\frac{dU(t)}{dt} = -rU(t).$$

This equation can be solved instantly to obtain $U(t) = Ce^{-rt}$, which shows that the perturbations decay, as long as they remain small.

This **linearization** procedure can be applied to any nonlinear autonomous equation

$$\frac{du}{dt} = f(u), \quad u = u(t).$$

Equilibrium solutions $u = u_e$ are solutions of the algebraic equation

$$f(u_e) = 0. \quad (5.24)$$

If $u(t) = u_e + U(t)$, where $U = U(t)$ is a small deviation from equilibrium, then it satisfies the perturbation equation

$$\frac{dU}{dt} = f(u_e + U).$$

Because U is assumed small, we may expand the right side in its Taylor series about u_e . Thus

$$f(u_e + U) = f(u_e) + f'(u_e)U + \frac{1}{2}f''(u_e)U^2 + \dots$$

Discarding the higher order nonlinear terms, while using (5.24), we obtain a linearized perturbation equation

$$\frac{dU}{dt} = f'(u_e)U.$$

This equation has general solution $U(t) = Ce^{\lambda t}$, where $\lambda = f'(u_e)$ is termed the *eigenvalue*; if $\lambda < 0$ the perturbation decays and the equilibrium u_e is stable, and if $\lambda > 0$ the perturbation grows and the equilibrium is unstable. If $\lambda = 0$ there is no information and we have to take into account additional terms in the Taylor series. In summary, the stability of an equilibrium state can be determined by examining the sign of the eigenvalue, i.e., the sign of the derivative of the right side of the differential equation, evaluated at that equilibrium state.

The linearization procedure is based upon the assumption that the perturbations are sufficiently small. The type of stability that results is called *local stability* since the deviations are not far from the equilibrium state. The procedure gives no results about *global stability*, i.e., how the system would evolve if any perturbation, regardless of its magnitude, were permitted.

Example 5.3

In the logistics equation (5.22) the right side is

$$f(u) = ru\left(1 - \frac{u}{K}\right).$$

Therefore,

$$f'(u) = r - \frac{2r}{K}u.$$

To determine local stability of the equilibrium state $u_e = K$ we check the eigenvalue

$$\lambda = f'(K) = r - \frac{2r}{K}K = -r.$$

Because $\lambda < 0$ the equilibrium $u_e = K$ is stable; small perturbations decay away. The other equilibrium solution is $u_e = 0$. In this case $\lambda = f'(0) = r > 0$, and therefore the zero state is unstable; if an initial small deviation were imposed, it would grow and the system would depart from equilibrium. \square

Stability for PDEs

A similar theory of local stability of equilibrium solutions can be developed for PDEs. In the interval $0 < x < L$ consider the reaction-diffusion equation

$$u_t = Du_{xx} + f(u),$$

with no-flux boundary conditions $u_x(0, t) = u_x(\pi, t) = 0$. Let $u(x, t) = u_e$ be a constant equilibrium solution (so that $f(u_e) = 0$). To fix the idea let $a = f'(u_e) > 0$. Note that the equilibrium solution satisfies the PDE and the boundary conditions. Next, let $U(x, t)$ be a small perturbation from the

equilibrium solution, or $u(x, t) = u_e + U(x, t)$. The *perturbation equation* is determined by substituting this expression into the PDE and the boundary conditions:

$$U_t = DU_{xx} + f(u_e + U), \quad U_x(0, t) = U_x(L, t) = 0.$$

To linearize this equation we expand, as above, the right side in a Taylor series and discard the nonlinear terms:

$$f(u_e + U) = f(u_e) + f'(u_e)U + \cdots = f'(u_e)U + \cdots$$

Then we obtain the **linearized perturbation equation**

$$U_t = DU_{xx} + aU, \quad a = f'(u_e) > 0 \quad (5.25)$$

subject to boundary conditions

$$U_x(0, t) = U_x(L, t) = 0. \quad (5.26)$$

This problem, which is on a bounded interval, can be solved by the separation of variables method (Chapter 4). We assume $U = g(x)h(t)$ and then substitute into the PDE (5.25) and boundary conditions (5.26) to obtain

$$gh' = Dg''h + agh,$$

or

$$\frac{h'}{h} = \frac{Dg''}{g} + a = \lambda.$$

Then $h = Ce^{\lambda t}$ and

$$g'' + \left(\frac{a - \lambda}{D}\right)g = 0, \quad g'(0) = g'(L) = 0.$$

This equation cannot have nontrivial exponential solutions that satisfy the boundary conditions; therefore $a - \lambda \geq 0$. In the case $\lambda = a$ we obtain a constant solution, and in the case $a - \lambda > 0$ we obtain

$$g(x) = A \sin \sqrt{\frac{a - \lambda}{D}}x + B \cos \sqrt{\frac{a - \lambda}{D}}x.$$

Applying $g'(0) = 0$ forces $A = 0$; then $g'(L) = 0$ implies

$$\sin \sqrt{\frac{a - \lambda}{D}}L = 0,$$

or

$$\sqrt{\frac{a - \lambda}{D}}L = n\pi, \quad n = 1, 2, \dots$$

Therefore, incorporating the case $\lambda = a$, we obtain eigenvalues

$$\lambda = \lambda_n = a - \frac{Dn^2\pi^2}{L^2}, \quad n = 0, 1, 2, \dots \quad (5.27)$$

The modal solutions are therefore

$$U_n(x, t) = e^{\lambda_n t} \cos \frac{n\pi}{L} x, \quad n = 0, 1, 2, \dots \quad (5.28)$$

What conclusions can we draw from this calculation? Because the general solution $U(x, t)$ to the boundary value problem (5.25–5.26) is a linear combination of the modal solutions (5.28),

$$U(x, t) = c_0 e^{at} + \sum_{n=1}^{\infty} c_n e^{\lambda_n t} \cos \frac{n\pi}{L} x,$$

it will decay if all of the modes decay, and it will grow if one of the modes grow. The constants c_n are determined by the initial perturbation. The spatial part of the modal solutions, i.e., the cosine, remains bounded. The amplitude factor $e^{\lambda_n t}$, and therefore the eigenvalues λ_n , determine growth or decay. Let us examine the modes. In the case $n = 0$ the eigenvalue is $\lambda_n = a$ and the modal solution is $c_0 e^{at}$, which grows exponentially. In fact, any mode satisfying $a \geq \frac{Dn^2\pi^2}{L^2}$ is unstable. Therefore, instabilities are likely to occur for modes of low frequency (n small), or in systems of large size L or low diffusion properties D . Oppositely, small systems with large diffusion constants are stabilizing, as are the high frequency modes. In the most general case the initial perturbation contains all modes and the steady state is locally unstable.

Cell Aggregation

We apply these ideas to a problem in cell aggregation. A slime mold population is a collection of unicellular amoeboid cells that feed on bacteria in the soil. When the food supply is plentiful, the bacteria are generally uniformly spatially distributed throughout the soil; but as the food supply becomes depleted and starvation begins, the amoeba start to secrete a chemical (cyclic AMP) that acts as an attractant to the other amoeba and aggregation sites form. The rest of the story is even more interesting as the aggregation sites evolve into slugs that ultimately develop into a sporangiophores consisting of a stalk and head containing new spores. The spores are released and the process begins anew. We are interested here in only the first part of this complicated problem, the onset of aggregation. We work in one spatial dimension.

Let $a = a(x, t)$ and $c = c(x, t)$ denote the density and concentration of the cellular amoeba and cyclic AMP, respectively. The fundamental conservation laws are

$$a_t = -\phi_x^{(a)}, \quad c_t = -\phi_x^{(c)} + F,$$

where $\phi^{(a)}$ and $\phi^{(c)}$ are the fluxes of the amoeba and the chemical, respectively. There are no source terms in the amoeba equation because we do not consider birth and death processes on the time scale of the analysis. The source term F in the chemical equation consists of two parts: production by the amoeba and degradation in the soil. We assume the chemical is produced by the amoeba at a rate proportional to the density of the amoeba, and the chemical degrades at a rate proportional to its concentration; i.e.,

$$F = fa - kc.$$

The chemical moves by diffusion only, and we assume Fick's law:

$$\phi^{(c)} = -\delta c_x,$$

where δ is the diffusion constant. The amoeba are also assumed to randomly diffuse, but there is another flux source for the amoeba, namely attraction to the chemical. We assume this attraction is *up the chemical gradient*, toward high concentrations of c . Additionally, it should depend on the amoeba population because that increases the magnitude of the chemical concentration released. This type of flow toward a source, induced by chemical gradients, is called **chemotaxis**. Therefore we assume

$$\begin{aligned}\phi^{(a)} &= \text{random flux} + \text{chemotactic flux} \\ &= -\mu a_x + \nu a c_x,\end{aligned}$$

where μ is the amoeba motility and ν is the strength of the chemotaxis, both assumed to be positive constants. Note that the random flux, having the form of Fick's law, has a negative sign since flow is "down the gradient" (from high to low densities), and the chemotactic flux has a positive sign since that term induces flow "up the chemical gradient" (from low to high concentrations). Putting all these equations all together gives the system

$$a_t = \mu a_{xx} - \nu (ac_x)_x, \quad c_t = \delta c_{xx} + fa - kc. \quad (5.29)$$

Both a and c satisfy no-flux boundary conditions, i.e., $a_x = c_x = 0$ at $x = 0, L$, which means there is no escape from the medium.

Notice that there will be an equilibrium solution $a = \bar{a}$, $c = \bar{c}$ to (5.29) provided

$$f\bar{a} = k\bar{c}.$$

That is, the production of the chemical equals its degradation. This equilibrium state represents the spatially uniform state in the soil before aggregation begins.

To determine the local stability of this state we let

$$a = \bar{a} + A(x, t), \quad c = \bar{c} + C(x, t),$$

where A and C are small perturbations. Substituting these quantities into (5.29) gives, after simplification, the perturbation equations

$$A_t = \mu A_{xx} - \nu \left((\bar{a} + A) C_x \right)_x, \quad C_t = \delta C_{xx} + fA - kC.$$

These equations are nonlinear because of the AC_x term in the amoeba equation. If we discard the nonlinear term on the assumption that the product of small terms is even smaller, then we obtain the linearized perturbation equations

$$A_t = \mu A_{xx} - \nu \bar{a} C_{xx}, \quad C_t = \delta C_{xx} + fA - kC. \quad (5.30)$$

Easily one can see that the perturbations satisfy the no-flux boundary conditions.

Motivated by our knowledge of the form of solutions to linear equations, we assume there are modal solutions of the form

$$A(x, t) = c_1 e^{\sigma t} \cos rx, \quad C(x, t) = c_2 e^{\sigma t} \cos rx, \quad (5.31)$$

where r and σ are to be determined, and c_1 and c_2 are constants. Notice the form of these assumed solutions. The spatial part is bounded and periodic with frequency r and period $2\pi/r$, and the temporal part is exponential with growth factor σ , which may be a real or complex number. If σ is negative or has a negative real part, then the perturbation will decay and the equilibrium state will return (stability); if σ is positive or has positive real part, then the perturbations will grow and the equilibrium will be unstable.

Let us ask why solutions of (5.30) should be of this form (5.31) without going through the entire separation of variables argument. Equations (5.30) are linear with constant coefficients, and both equations contain A and C and their derivatives. If we are to have a solution, then all the terms must match up in one way or another in order to cancel. So both A and C must essentially have the same form. Because there is a first derivative in t , the time factor must be exponential so it will cancel, and the spatial part must be a sine or a cosine because of the appearance second spatial derivative. We anticipate the cosine function because of the no-flux boundary conditions, as in Chapter 4. If we substitute (5.31) into (5.30) we obtain the two equations

$$\left(\sigma + \mu r^2 \right) c_1 - \nu \bar{a} r^2 c_2 = 0, \quad -f c_1 + \left(\sigma + k + \delta r^2 \right) c_2 = 0$$

which relate all the parameters. We may regard these two equations as two linear, homogeneous for the constants c_1 and c_2 . If we want a nontrivial solution for c_1 and c_2 , then from matrix theory the determinant of the coefficient matrix must be zero. That is,

$$\left(\sigma + \mu r^2 \right) \left(\sigma + k + \delta r^2 \right) - f \nu \bar{a} r^2 = 0,$$

which is an equation relating the temporal growth factor σ , the spatial frequency r , and the other constants in the problem. Expanded, this equation is a quadratic in σ ,

$$\sigma^2 + \gamma_1\sigma + \gamma_2 = 0,$$

where

$$\gamma_1 = r^2(\mu + \gamma) + k > 0, \quad \gamma_2 = r^2 \left[\mu(\delta r^2 + k) - f\nu\bar{a} \right].$$

The roots of the quadratic are

$$\sigma = \frac{1}{2} \left(-\gamma_1 \pm \sqrt{\gamma_1^2 - 4\gamma_2} \right).$$

Clearly one of the roots is always negative or has negative real part. The other root can have positive or negative real part, depending upon the value of the discriminant $\gamma_1^2 - 4\gamma_2$. We are interested in determining if there are parameter choices that lead to an instability; so we want σ positive. Hence, γ_2 must be negative, or

$$\mu(\delta r^2 + k) < f\nu\bar{a}.$$

If this inequality holds, there is an unstable mode and perturbations will grow. We analyze this further.

The number r is the spatial frequency of the perturbations. Applying the no-flux boundary conditions forces

$$r = \frac{n\pi}{L}, \quad n = 0, 1, 2, 3, \dots$$

For each value of n we obtain a frequency $r = r_n$ and a corresponding growth factor σ_n . The n th mode will therefore grow and lead to local instability when

$$\mu \left(\delta \frac{n^2\pi^2}{L^2} + k \right) < f\nu\bar{a}. \quad (5.32)$$

We can now ask what factors destabilize the uniform, equilibrium state in the amoeba-cAMP system and therefore promote aggregation. That is, when is (5.32) likely to hold? We can list the factors that may make the left side of the inequality (5.32) smaller than the right side: low motility μ of the bacteria; low degradation rate k or large production rate f of cAMP; large chemotactic strength ν ; large dimensions L of the medium; a small value of n (thus, low frequency, or long wave length, perturbations are less stabilizing than short wave, or high frequency, perturbations); decreasing the diffusion constant of the cAMP. Figure 5.5 shows time snapshots of the amoeba density for the mode $n = 2$ when it is unstable. The intervals where the amplitude is high correspond to higher concentrations of amoeba, i.e., regions of aggregation.

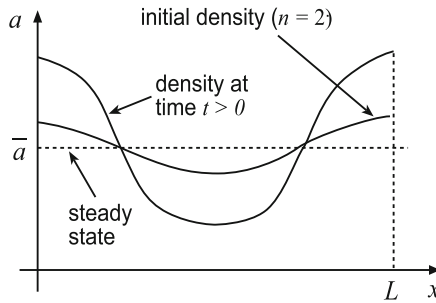

Figure 5.5 Plot showing the growing amoeba density at time t when the uniform state is unstable to local perturbations in the mode $n = 2$

EXERCISES

1. Consider an fish population that grows logistically, and at the same time is harvested at a rate proportional to the population. The model is

$$\frac{du}{dt} = ru \left(1 - \frac{u}{K} \right) - hu$$

where r , K , and h are the growth rate, carrying capacity, and harvesting rate, respectively. Find all the equilibria and analyze their stability. What are the possible long term fish populations?

2. (**Turing system**) Consider the system of reaction diffusion equations on the spatial domain $0 < x < L$ given by

$$u_t = \alpha u_{xx} + f(u, v), \quad v_t = \beta v_{xx} + g(u, v)$$

with no-flux boundary conditions $u_x = v_x = 0$ at $x = 0, L$. Let $u = \bar{u}$, $v = \bar{v}$ be an equilibrium solution and define small perturbations U and V from equilibrium given by

$$u = \bar{u} + U(x, t), \quad v = \bar{v} + V(x, t).$$

- (a) Show that U and V satisfy no-flux boundary conditions and the linearized perturbation equations

$$U_t = \alpha U_{xx} + f_u(\bar{u}, \bar{v})U + f_v(\bar{u}, \bar{v})V, \quad (5.33)$$

$$V_t = \beta V_{xx} + g_u(\bar{u}, \bar{v})U + g_v(\bar{u}, \bar{v})V. \quad (5.34)$$

(b) Introduce matrix notation

$$\vec{W} = \begin{pmatrix} U \\ V \end{pmatrix}, \quad D = \begin{pmatrix} \alpha & 0 \\ 0 & \beta \end{pmatrix}, \quad J = \begin{pmatrix} f_u(\bar{u}, \bar{v}) & f_v(\bar{u}, \bar{v}) \\ g_u(\bar{u}, \bar{v}) & g_v(\bar{u}, \bar{v}) \end{pmatrix},$$

and show that (5.33–5.34) can be written as

$$\vec{W}_t = D\vec{W}_{xx} + J\vec{W}. \quad (5.35)$$

(c) Assume modal solutions to (5.35) of the form

$$\vec{W} = \vec{C} e^{\sigma_n t} \cos \frac{n\pi x}{L}, \quad \vec{C} = \begin{pmatrix} c_{1n} \\ c_{2n} \end{pmatrix}, \quad n = 0, 1, 2, \dots,$$

and show that for a nontrivial solution we must have

$$\det \left(\sigma_n I + \frac{n^2 \pi^2}{L^2} D - J \right) = 0. \quad (5.36)$$

When expanded, this equation is a quadratic equation for the growth factor σ_n of the n th mode. The roots σ_n depend upon the diffusion constants α, β , the equilibrium solution \bar{u}, \bar{v} , the size of the medium L , and the wavelength $2L/n$ of the perturbation. If one can find values of the parameters that make one of the roots positive or have positive real part, then there is an unstable mode.

3. Apply the method of Exercise 2 to examine the stability of the steady state of the Turing system

$$u_t = Du_{xx} + 1 - u + u^2v, \quad v_t = v_{xx} + 2 - u^2v, \quad 0 < x < \pi,$$

under no-flux boundary conditions. Specifically, write the condition (5.36) and determine values of D for which various modes (n) are unstable.

4. Consider Fisher's equation with Dirichlet boundary conditions:

$$\begin{aligned} u_t &= u_{xx} + u(1-u), & -\frac{\pi}{2} < x < \frac{\pi}{2}, \\ u &= 3 \quad \text{at} \quad x = \pm \frac{\pi}{2}. \end{aligned}$$

(a) Show that $u_e(x) = \frac{3}{1+\cos x}$ is a *nonconstant* steady state solution.

(b) Define perturbations $U(x, t)$ by the equation $u = u_e(x) + U(x, t)$ and find the linearized perturbation equation and boundary conditions for $U(x, t)$.

(c) Assume a solution to the linearized equation of the form $U = e^{\sigma t}g(x)$ and show that g must satisfy

$$g'' + \frac{\cos x - 5}{1 + \cos x}g = \sigma g, \quad g = 0 \quad \text{at} \quad x = \pm \frac{\pi}{2}. \quad (5.37)$$

(d) Show that if (5.37) has a nontrivial solution, then $\sigma < 0$, thereby showing local stability of the steady solution. Hint: Consider two cases, when g is positive and when g is negative on the interval and then examine at the signs of g'' and the other terms in (5.37) at a maximum or minimum point.

6

Numerical Computation of Solutions

Up to this point we have examined PDEs from an analytical viewpoint, often seeking a formula for the solution. Now we devote a brief chapter to solving PDEs numerically. It is a fact that in industry and applied science PDEs are almost always solved numerically on a computer; most real-world problems are too complicated to solve analytically. And, even if a problem can be solved analytically, usually the solution is in the form of a difficult integral or an infinite series, requiring a numerical calculation anyway. This chapter presents a brief introduction to one method, the finite difference method. There are many other methods, for example, the finite element method, to mention only one. Numerical methods for PDEs have been and continue to be one of the most active research areas in applied mathematics, computer science, and the applied sciences as investigators seek faster and more accurate algorithms. Another feature is that numerical methods give tremendous insight into the basic nature and theory of PDEs. The reader will find a large amount of literature on the subject; it is a field within itself. Brief introductions to finite difference methods can be found in Smith (1978), Logan (1987), and Holmes (2007).

In the **finite difference method** the idea is to replace the *continuous* PDE by a *discrete* algebraic problem that can be solved on a computer in finitely many steps. The result is a discrete solution which is known approximately at only finitely many points of the domain. Simply, partial derivatives in the equation are replaced by their difference-quotient approximations; this leads to a difference equation relating the discrete approximations of the solution. We then develop a computer code to solve for the discrete approximations. Although the procedure is straightforward, it does not come without risks.

If care is not taken, the procedure can lead to disastrous results even when it appears that the discrete approximation to the continuous problem is very sensible.

6.1 Finite Difference Approximations

Discrete approximations for derivatives can be obtained by **Taylor's theorem**, one of the most important results in calculus. It gives both the form and the accuracy of the approximation. If we assume a function f is sufficiently differentiable, say, having $n + 1$ continuous derivatives in a neighborhood of a point x , then Taylor's theorem states that for h sufficiently small, $f(x)$ can be expanded in as

$$f(x+h) = f(x) + f'(x)h + \frac{1}{2}f''(x)h^2 + \frac{1}{3}f'''(x)h^3 + \cdots + \frac{1}{n!}f^{(n)}(x)h^n \\ + \frac{1}{(n+1)!}f^{(n+1)}(\bar{x})h^{n+1},$$

where \bar{x} is some point between x and $x+h$. The last term in this expansion is the *error term*, and we say it is order $n+1$; we write it as $O(h^{n+1})$, a general expression meaning that it is some constant times the factor h^{n+1} .

The reader should be familiar with this approximation strategy for initial value problems for ordinary differential equations. We review the simplest method.

Example 6.1

(Euler's Method) The problem is to numerically solve the initial value problem (IVP)

$$y' = f(t, y), \quad t_0 < t < T; \quad y(t_0) = y_0,$$

where f and f_y are continuous in both arguments in an open neighborhood containing the initial point (t_0, y_0) . These conditions guarantee a unique solution to the IVP on an interval containing t_0 . The first step in computing a numerical approximation is to discretize the interval $t_0 \leq t \leq T$ by defining a finite number of points $t_n = t_0 + nh$, $n = 0, 1, \dots, N$, where h is the **step size** defined by $h = (T - t_0)/N$. Thus, $t_{n+1} = t_n + h$. At each discrete point t_n of the domain we determine an approximation Y_n to the exact value $y(t_n)$ of the solution at that point. From Taylor's theorem we know that

$$y(t_{n+1}) = y(t_n) + hy'(t_n) + O(h^2) = y(t_n) + hf(t_n, y(t_n)) + O(h^2).$$

If we replace $y(t_n)$ by its approximation Y_n and drop the $O(h^2)$ term, the so-called truncation error, we get

$$Y_{n+1} = Y_n + hf(t_n, Y_n), \quad n = 0, 1, \dots, N, \quad Y_0 = y_0.$$

This is the *Euler method*, and we can easily compute the approximations Y_1, Y_2, \dots , recursively from $n = 0$ to $n = N - 1$. The Euler method is a *marching scheme* where the values are computed successively, forward in time. It is only one of many, many schemes designed for numerical computation of IVPs. A MATLAB script named *EulerMethod* at the end of the chapter carries out this iteration process for the initial value problem

$$y' = -0.1 \left(y - 15 - 12 \cos \left(\frac{3.14t}{12} \right) \right), \quad y(0) = 68$$

over the interval $0 \leq t \leq 72$ using 1000 time steps. \square

Solving PDEs numerically requires finite difference approximations for various partial derivatives. If $u = u(x, t)$ is a sufficiently smooth function, then Taylor's theorem implies

$$u(x+h, t) = u(x, t) + u_x(x, t)h + \frac{1}{2}u_{xx}(x, t)h^2 + \frac{1}{3!}u_{xxx}(x, t)h^3 + O(h^4), \quad (6.1)$$

where h is an increment of x . Therefore, taking only three terms on the right, we obtain the *forward difference approximation*

$$u_x(x, t) = \frac{u(x+h, t) - u(x, t)}{h} + O(h).$$

In a similar way, if k is an increment of t ,

$$u_t(x, t) = \frac{u(x, t+k) - u(x, t)}{k} + O(k).$$

To obtain an approximation for u_{xx} , we can write (6.1) for h replaced by $-h$ to obtain

$$u(x-h, t) = u(x, t) - u_x(x, t)h + \frac{1}{2}u_{xx}(x, t)h^2 - \frac{1}{3!}u_{xxx}(x, t)h^3 + O(h^4).$$

Adding this expression to (6.1) and solving for u_{xx} gives the *centered difference approximation*

$$u_{xx} = \frac{u(x-h, t) - 2u(x, t) + u(x+h, t)}{h^2} + O(h^2),$$

which is an approximation for the second derivative. Similarly,

$$u_{tt} = \frac{u(x, t-k) - 2u(x, t) + u(x, t+k)}{k^2} + O(k^2).$$

6.2 Explicit Scheme for the Heat Equation

The idea of marching forward in time, as in Euler's method, goes over to evolution problems in PDEs. In this section we illustrate an explicit finite difference method for an initial boundary value problem associated with the diffusion equation:

$$u_t = Du_{xx}, \quad 0 < x < 1, \quad t > 0, \quad (6.2)$$

$$u(0, t) = u(1, t) = 0, \quad t > 0, \quad (6.3)$$

$$u(x, 0) = f(x), \quad 0 < x < 1. \quad (6.4)$$

The first step to discretize the region of space–time where we want to obtain a solution. In this case the region is $0 \leq x \leq 1$, $0 \leq t \leq T$. We put a bound on time because in practice we only solve a problem up until a finite time. Discretizing means defining a two-dimensional **lattice** of points in this space–time region by

$$x_j = jh, \quad t_n = nk, \quad j = 0, 1, \dots, J; \quad n = 0, 1, \dots, N,$$

where the fixed numbers h and k are the spatial and temporal *step sizes*, respectively, given by $h = 1/J$ and $k = 1/N$. The integer J is the number of subintervals in $0 \leq x \leq 1$, and N is the number of time steps to be taken. Figure 6.1 shows the lattice of points; this lattice is also called a **grid**, and the points are called **nodes**. At each lattice point (x_j, t_n) we seek an approximation, which we call U_j^n , to the exact value $u(x_j, t_n)$ of the solution. Note that the superscript n on U_j^n is an index referring to time, not an exponent; and the index subscript j refers to space. We can regard the grid function U_j^n as a two-dimensional array, or matrix, where n is a column index and j is a row index. To obtain equations for the approximations U_j^n , we replace the partial derivatives in the PDE by their difference approximations obtained in Section 6.1. So the continuous PDE (6.2) at the point (x_j, t_n) is replaced by the difference equation

$$\frac{U_j^{n+1} - U_j^n}{k} = D \frac{U_{j-1}^n - 2U_j^n + U_{j+1}^n}{h^2},$$

where we have dropped the error terms. Solving for U_j^{n+1} gives

$$U_j^{n+1} = U_j^n + r (U_{j-1}^n - 2U_j^n + U_{j+1}^n), \quad (6.5)$$

where

$$r = \frac{kD}{h^2}.$$

Observe that the difference equation (6.5) relates the approximate values of the solution at the four points (x_{j-1}, t_n) , (x_j, t_n) , (x_{j+1}, t_n) , (x_j, t_{n+1}) . These four

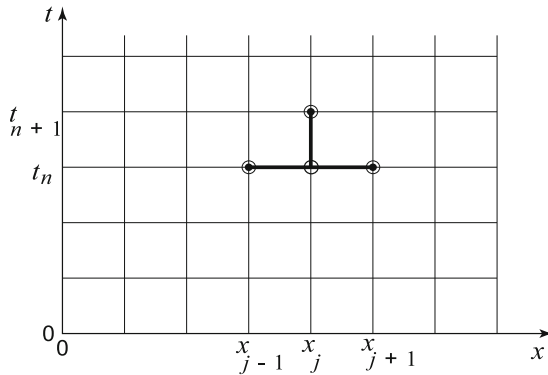

Figure 6.1 The discrete lattice, or grid, and the computational atom of the explicit scheme for diffusion equation. The atom permits calculation of U_j^{n+1} at the $(n+1)$ st time level in terms of the three values U_{j-1}^n , U_j^n , U_{j+1}^n at the previous time level n . So we can fill up an entire grid row by knowing the grid values at the preceding row

points form the **computational atom** for the difference scheme (see Figure 6.1).

The difference equation (6.5) gives the approximate solution at the node (x_j, t_{n+1}) in terms of approximations at three earlier nodes. Now we see how to fill up the lattice with approximate values. We know the values at $t = 0$ from the initial condition (6.4). That is, we know

$$U_j^0 = f(x_j), \quad j = 0, 1, \dots, J.$$

From the boundary conditions (6.3) we also know

$$U_0^n = 0, \quad U_J^n = 0, \quad n = 1, 2, \dots, N.$$

The difference formula (6.5) can now be applied at all the *interior* lattice points, beginning with the values at the $t = 0$ level, to compute the values at the $t = t_1$ level, then using those to compute the values at the $t = t_2$ level, and so on. Therefore, using the difference equation, we can march forward in time, continually updating the previous temperature profile. Think of filling out the array U_j^n , row by row, i.e., time after time, in a marching type scheme. In physical terms, the numerical solution carries the initial temperature distribution forward in time; along each horizontal time line n , we can think of the j values, U_j^n , $j = 0, 1, 2, \dots, J$, as an approximate time profile.

A finite difference scheme, or algorithm, like (6.5) is called an **explicit scheme** because it permits the explicit calculation of an approximation at the next time step in terms of values at a previous time step. Because of the error (called the truncation error) that is present in (6.5) due to replacing derivatives by differences, the scheme is not always accurate. As it turns out, if the time step k is too large, then highly inaccurate results will be obtained. It can be shown that we must have the **stability condition**

$$r = \frac{kD}{h^2} \leq \frac{1}{2}$$

for the scheme to converge. This condition constrains the time step according to $k < 0.5h^2/D$. Experiments that illustrate this behavior are suggested in the exercises.

It is straightforward to code the explicit algorithm (6.5) described above to calculate approximate temperatures in a rod. A simple MATLAB program listing entitled *ExplicitHeat* is given at the end of the chapter. The solution surface is plotted in Figure 6.2.

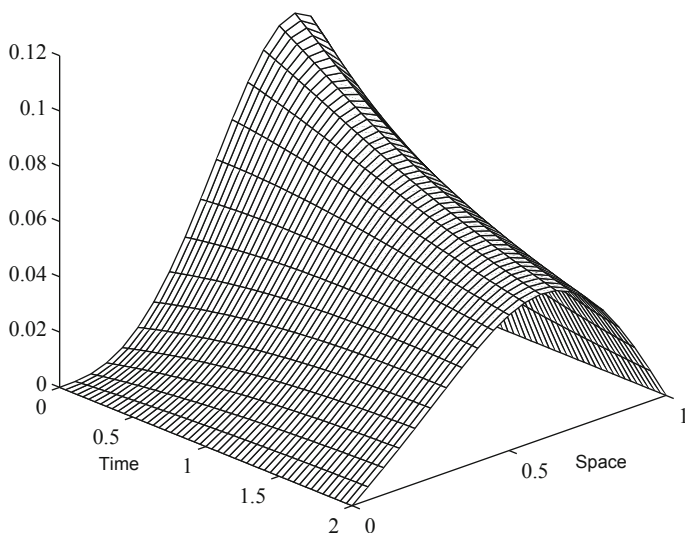

Figure 6.2 Numerical solution to the problem (6.2), (6.3), (6.4) with initial temperature $f(x) = x^3(1 - x)$, diffusivity $D = 0.02$, on $0 \leq x \leq 1$, $0 \leq t \leq 2$

von Neumann Stability Analysis

There are three sources of errors in applying finite difference schemes to differential equations: (1) *truncation errors*, which measure the errors in replacing the differential equation by a difference equation; (2) errors propagated in a computation using the difference scheme itself; (3) *roundoff errors* accumulated from the computation because of the finite-digit arithmetic, or representation of real data.

We have seen that truncation errors are proportional to the step sizes taken to approximate derivative, e.g., $O(h^2)$, etc. The origin of roundoff error is a topic we leave to other sources, for example, computer science. We focus here on (2), that is, how does a difference equation itself propagate incorrect information? Even if the difference approximation has a very high accuracy measured by the truncation error, we show that the difference scheme can still lead to horrendous results. The analysis, which is one of several, is called **von Neumann stability analysis**. It deals with the issue of stability, which was discussed earlier in the text; namely, if an initial error is small, does the error at later times remain small when propagated by the difference scheme?

Consider the problem

$$u_t - u_{xx} = 0, \quad x \in \mathbb{R}, \quad t > 0, \quad u(x, 0) = \cos \alpha x, \quad x \in \mathbb{R},$$

where $\alpha > 0$ can be regarded as a wave number, or the number of oscillations per 2π . This problem can be solved exactly, and the solution is

$$u(x, t) = e^{-\alpha^2 t} \cos \alpha x.$$

Clearly u remains bounded as $t \rightarrow \infty$. Next, let us set up this problem numerically using the explicit scheme. For the infinite domain $t > 0$ take $x_j = \pm jh$, $j = 0, 1, 2, \dots$, $t_n = nk$, $n = 0, 1, 2, \dots$. The PDE is approximated by the difference equation (6.5),

$$U_j^{n+1} = U_j^n + r(U_{j-1}^n - 2U_j^n + U_{j+1}^n).$$

The initial condition gives

$$U_j^0 = \cos \alpha x_j, \quad j = 0, \pm 1, \pm 2, \dots$$

Think of the initial condition as defining a distribution of errors at time $t = 0$. We look for a complex solution of the discrete problem in the form

$$U_j^n = M^n e^{i\alpha x_j},$$

where the amplitude factor M is to be determined. (Note: we can recover the real solution by taking the real part of the complex solution.) Substituting this into the difference equation gives

$$\begin{aligned} M &= r - 1 + 2r \cos \alpha h \\ &= 1 - 4r \sin^2 \frac{\alpha h}{2}. \end{aligned}$$

Therefore, the real solution is

$$U_j^n = \left(1 - 4r \sin^2 \frac{\alpha h}{2} \right)^n \cos \alpha x_j.$$

It is clear that U will be bounded whenever

$$\left| 1 - 4r \sin^2 \frac{\alpha h}{2} \right| < 1 \quad \text{or} \quad r \leq \frac{1}{2 \sin^2 \frac{\alpha h}{2}}.$$

If $r \leq \frac{1}{2}$ this is guaranteed. If on the other hand $r > \frac{1}{2}$, then there is always a value of α for which $|M| > 1$. It follows that the explicit scheme with $r > \frac{1}{2}$ is not stable because bounded initial conditions are propagated by the scheme so that they become unbounded. For $r \leq \frac{1}{2}$ we say the scheme is von Neumann stable.

Example 6.2

The following diagram shows the result of applying the explicit scheme (6.5) in the simple case $r = 1$, which is an unstable case. In this case, the difference equation becomes

$$U_j^{n+1} = -U_j^n + U_{j-1}^n + U_{j+1}^n.$$

At time $t_0 = 0$ we assume there is an initial error ϵ at $x_0 = 0$. Using the scheme, the values of U_j^n , $j = 0, \pm 1, \pm 2, \pm 3, \dots$ were computed (by hand) for subsequent time lines t_1, t_2, t_3 , etc. One can observe that the error propagates, spreading and growing in time. It would make a numerical approximation completely invalid. \square

| | | | | | | | |
|-------|------------|--------------|--------------|--------------|--------------|--------------|-------------|
| t_3 | ϵ | -3ϵ | 6ϵ | -7ϵ | 6ϵ | -3ϵ | $-\epsilon$ |
| t_2 | 0 | ϵ | -2ϵ | 3ϵ | -2ϵ | ϵ | 0 |
| t_1 | 0 | 0 | ϵ | $-\epsilon$ | ϵ | 0 | 0 |
| t_0 | 0 | 0 | 0 | ϵ | 0 | 0 | 0 |
| | x_{-3} | x_{-2} | x_{-1} | x_0 | x_1 | x_2 | x_3 |

Example 6.3

(Explicit Scheme for the Wave Equation) This same type of explicit marching procedure that worked for the heat equation works for initial value problems associated with the wave equation. Consider the problem

$$u_{tt} = c^2 u_{xx}, \quad 0 < x < 1, \quad t > 0, \quad (6.6)$$

$$u(0, t) = u(1, t) = 0, \quad t > 0, \quad (6.7)$$

$$u(x, 0) = f(x), \quad u_t(x, 0) = g(x), \quad 0 \leq x \leq 1. \quad (6.8)$$

First we discretize the space-time domain as before and form a lattice $x_j = jh$, $t_n = nk$, $j = 0, 1, \dots, J$, $n = 0, 1, \dots, N$. We can approximate the PDE by

$$\frac{U_j^{n-1} - 2U_j^n + U_j^{n+1}}{k^2} = c^2 \frac{U_{j-1}^n - 2U_j^n + U_{j+1}^n}{h^2},$$

which leads to

$$U_j^{n+1} = 2(1 - s^2)U_j^n + s^2(U_{j-1}^n + U_{j+1}^n) - U_j^{n-1},$$

where

$$s = \frac{ck}{h}.$$

The computational atom for this explicit scheme is shown in Figure 6.3. To

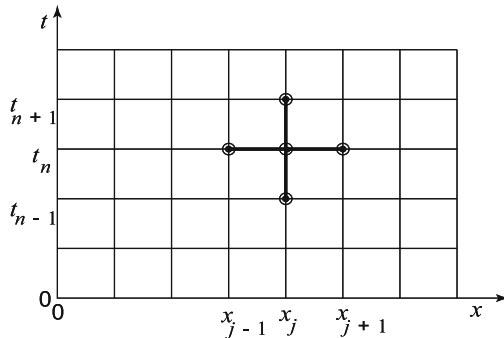

Figure 6.3 Computational atom for the wave equation. The values at the $(n + 1)$ st time level depend on the two previous times, n and $n - 1$

compute the value at the $(n + 1)$ st time step we now need values from the previous *two* time steps. Therefore, to start the marching scheme we require

values from the first two ($t_0 = 0$ and $t_1 = k$) time rows. The $t = 0$ row is given by the initial condition $u(x, 0) = f(x)$; so we have

$$U_j^0 = f(x_j), \quad j = 0, 1, \dots, J.$$

The $t = t_1$ time row can be computed using the initial velocity condition $u_t(x, 0) = g(x)$, which we approximate by a forward difference formula,

$$\frac{U_j^1 - U_j^0}{k} = g(x_j), \quad j = 1, 2, \dots, J - 1.$$

Thus, the values U_j^1 at the second row are

$$U_j^1 = U_j^0 + kg(x_j).$$

Now we have the ingredients to start the scheme and march forward in time to fill up the entire grid with values, marching forward from time row to time row. Again there is a stability condition, namely, $s \leq 1$, or

$$c \leq \frac{h}{k}.$$

This is the **CFL** condition, or the Courant–Friedrichs–Lax condition. Physically, it states that the speed h/k at which lattice points are being calculated must exceed the speed c that waves are propagated in the system. Thus the calculated values at the lattice points at a given time level will contain all of the information about the wave at the previous time level. We ask the reader to write a code for the explicit scheme to solve the wave equation. \square

Example 6.4

(Other boundary conditions) In the explicit marching scheme for the heat equation we considered fixed, Dirichlet boundary conditions. For example, this forces the values U_0^n along the grid points $(0, n)$ to be fixed along the left boundary. If, however, the left boundary has a Neuman condition, then we do not know U_0^n *a priori*, and the values must be calculated. For illustration, assume a boundary condition of the form

$$u_x(0, t) = b(t), \quad t > 0.$$

Using the spatial grid $x_j = jh$, $j = 0, 1, 2, \dots$, as before, we discretize this condition by

$$\frac{u(x_1, t_n) - u(0, t_n)}{h} = b(t_n) + O(h),$$

for each n . In terms of the grid function U , this is

$$\frac{U_1^n - U_0^n}{h} = b(t_n), \quad \text{or } U_0^n = U_1^n - hb(t_n), \quad n = 1, 2, 3, \dots$$

Therefore, given the values along the n th row, the calculation of the values along the $(n + 1)$ st row is

$$\begin{aligned} \text{for } j = 1 \text{ to } J - 1; U_j^{n+1} &= U_j^n + r(U_{j-1}^n - 2U_j^n + U_{j+1}^n); \text{ end} \\ U_0^{n+1} &= U_1^{n+1} - hb(t_n); \end{aligned}$$

Similar conditions can be derived for radiation boundary conditions. The wave equation can be handled in a similar way. \square

EXERCISES

1. Use Euler's method with step size $h = 0.1$ to numerically solve the initial value problem $y' = -2ty + y^2$, $y(0) = 1$ on the interval $0 \leq t \leq 2$. Compare your approximations with the exact solution.
2. Use the notation in this section, derive the centered difference approximation to the first derivative,

$$u'(x) = \frac{u(x+h) - u(x-h)}{2h} + O(h^2).$$

3. Develop an explicit scheme to solve the heat conduction problem

$$\begin{aligned} u_t &= u_{xx}, \quad 0 < x < 1, \quad t > 0, \\ u(0, t) &= 1, \quad u_x(1, t) = -(u(1, t) - g(t)), \quad t > 0, \\ u(x, 0) &= 0, \quad 0 < x < 1. \end{aligned}$$

Hint: Approximate the radiation condition $u_x(1, t) = -(u(1, t) - g(t))$ by

$$\frac{u(x_J, t_n) - u(x_{J-1}, t_n)}{h} = -(u(x_J, t_n) - g(t_n)).$$

Pick $g(t) = 1$ and compute an approximate solution surface. Finally, describe the physical context of this problem.

4. Write a program in some programming language or in a computer algebra package to solve the hyperbolic problem (6.6)–(6.8) when $f(x) = 0$ and $g(x) = x(1 - x)$ with $c = 0.25$. Take $h = 0.125$ and experiment with various time step sizes k and illustrate the validity of the CFL condition. Compare with the exact solution.
5. Consider the explicit method for the wave equation wave equation in $x \in \mathbb{R}$, $t > 0$ with CFL parameter $s = 2$. Take the initial condition $f(x)$ at the discrete grid points x_j to be $\dots, 0, 0, 0, 1, 2, 1, 0, 0, 0, \dots$ and assume $u_t(x, 0) = 0$ for all x . By hand, compute the values of U_j^n for the four time levels $n = 1, 2, 3, 4$. Next make the same calculation with $s = 1$. Discuss your observations.

6. Consider the Cauchy problem for the advection equation, $u_t + cu_x = 0$, where $c > 0$.

a) Expand $u(x, t + k)$ in a Taylor series up to $O(k^3)$ terms. Then use the advection equation to obtain

$$u(x, t + k) = u(x, t) - ck u_x(x, t) + \frac{c^2 k^2}{2} u_{xx}(x, t) + O(k^3).$$

b) Replace u_x and u_{xx} by centered difference approximations to obtain the explicit scheme

$$U_j^{n+1} = (1 - s^2)U_j^n + \frac{1}{2}(1 + s)U_{j-1}^n - \frac{1}{2}(1 - s)U_{j+1}^n, \quad s = \frac{ck}{h}.$$

This is the **Lax–Wendroff method**. It is von Neumann stable for $0 < s \leq 1$ and it is widely used to solve both linear and nonlinear first-order hyperbolic systems.

c) Use the Lax–Wendroff method to numerically solve $u_t + 3u_x = 0$ in the upper half-plane where $u(x, 0) = 2x(2 - x)$ if $0 \leq x \leq 2$ and $u(x, 0) = 0$ otherwise. Take $h = 0.2$, $k = 0.05$. Compare your answer to the exact solution.

6.3 Laplace's Equation

Next we solve a Dirichlet problem for Laplace's equation in the unit square with prescribed values on the boundary of the square. This Dirichlet problem is a pure boundary value problem, and we should not expect an explicit marching-type scheme to work; there is no guarantee that when we march from one boundary in the problem to another we will reach the already specified values at that boundary. This means that we must solve for the approximate values at all of the interior lattice points simultaneously. To illustrate the procedure we consider the Dirichlet problem

$$u_{xx} + u_{yy} = 0, \quad 0 < x < 1, 0 < y < 1, \quad (6.9)$$

$$u(0, y) = u(1, y) = 0, \quad 0 < y < 1, \quad (6.10)$$

$$u(x, 0) = f(x), \quad u(x, 1) = 0, \quad 0 \leq x \leq 1. \quad (6.11)$$

We discretize the unit square by defining lattice points

$$x_i = ih, \quad y_j = jk, \quad i = 0, 1, \dots, I; \quad j = 0, 1, \dots, J,$$

where $h = 1/I$ and $k = 1/J$ are the fixed step sizes in the x and y directions, respectively. We let $U_{i,j}$, with two lower subscripts, denote the approximate value of $u(x_i, y_j)$. Then Laplace's equation can be approximated at the lattice point (x_i, y_j) by the difference equation

$$\frac{U_{i-1,j} - 2U_{i,j} + U_{i+1,j}}{h^2} + \frac{U_{i,j-1} - 2U_{i,j} + U_{i,j+1}}{k^2} = 0.$$

The reader may wish to review Section 1.8, where a similar approximation is made when $h = k$. The difference equation can be rewritten as

$$U_{i,j} = \frac{k^2}{2k^2 + 2h^2}(U_{i-1,j} + U_{i+1,j}) + \frac{h^2}{2k^2 + 2h^2}(U_{i,j-1} + U_{i,j+1}). \quad (6.12)$$

The computational atom is shown in Figure 6.4. The difference equation relates the node at the center of the atom to four adjacent nodes. As we observed in Section 1.8, if $h = k$, then this difference equation states that the value at the center node is approximately the average of the values at the four adjacent nodes; if $h \neq k$, the approximate value at the center is a weighted average of the four surrounding values.

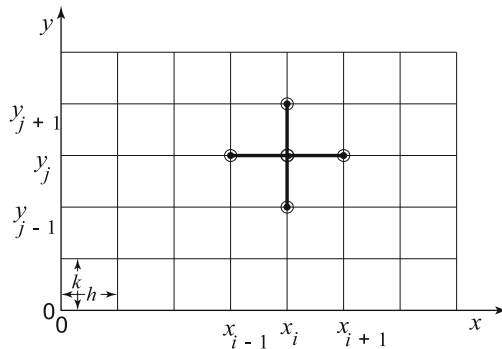

Figure 6.4 Computational atom for Laplace's equation

The strategy is this. The values of $U_{i,j}$ are known at the nodes on the boundary of the square. We want to find the values at the $(I - 1) \times (J - 1)$ interior lattice points. Therefore, we apply the difference equation (6.12) to each interior lattice point, i.e., for $i = 1, \dots, I - 1$; $j = 1, \dots, J - 1$. The result is a linear-algebraic system consisting of $(I - 1) \times (J - 1)$ equations in the $(I - 1) \times (J - 1)$ unknowns $U_{i,j}$. Therefore, we have reduced the Dirichlet problem to the linear algebra problem of solving for grid function $U_{i,j}$ at the interior nodes.

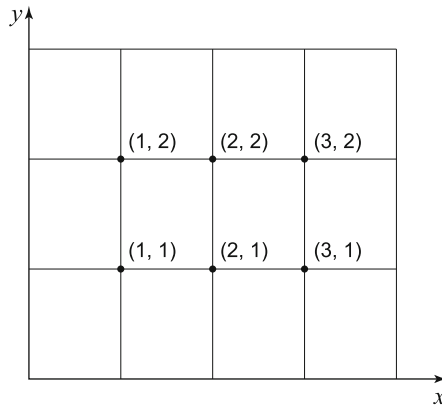

Figure 6.5 Discrete lattice

Example 6.5

In (6.11) take $f(x) = x^3(1 - x)$. To illustrate the procedure take $I = 4$ and $J = 3$; thus $j = 1/4$ and $k = 1/3$. See Figure 6.5. Then

$$\frac{h^2}{2k^2 + 2h^2} = 0.18, \quad \frac{k^2}{2k^2 + 2h^2} = 0.32.$$

There are six interior lattice points where the solution is to be found. By the boundary conditions, the values along the top and two sides are zero, and the values along the lower boundary are $U_{0,0} = 0, U_{1,0} = 0.0117, U_{2,0} = 0.0625, U_{3,0} = 0.1054, U_{4,0} = 0$. Now we apply the difference equation (6.12) successively at the six points $(i, j) = (1, 1), (1, 2), (2, 1), (2, 2), (3, 1), (3, 2)$ to obtain the six coupled algebraic equations

$$\begin{aligned} U_{1,1} &= 0.32(0 + U_{2,1}) + 0.18(0.0117 + U_{1,2}), \\ U_{1,2} &= 0.32(0 + U_{2,2}) + 0.18(U_{1,1} + 0), \\ U_{2,1} &= 0.32(U_{1,1} + U_{3,1}) + 0.18(0.0625 + U_{2,2}), \\ U_{2,2} &= 0.32(U_{1,2} + U_{3,2}) + 0.18(U_{2,1} + 0), \\ U_{3,1} &= 0.32(U_{2,1} + 0) + 0.18(0.1054 + U_{3,2}), \\ U_{3,2} &= 0.32(U_{2,2} + 0) + 0.18(U_{3,1} + 0). \end{aligned}$$

We can solve these six linear equations to obtain the approximate solution at the six interior nodal points:

$$\begin{aligned} U_{1,1} &= 0.007, \quad U_{1,2} = 0.003, \quad U_{2,1} = 0.015, \\ U_{2,2} &= 0.006, \quad U_{3,1} = 0.024, \quad U_{3,2} = 0.006. \quad \square \end{aligned}$$

In the previous example we solved the linear system easily on a calculator. But if the lattice has a large number of nodes, which is the usual case, then direct solution is inefficient, even though the coefficient matrix for the system is tridiagonal (nonzero only on the sub-, super- and main diagonals). Another way to solve a linear system is by an iterative process known as the **Gauss–Seidel method**. In this method we fix the values of the array $U_{i,j}$ at the known boundary points and then initialize the array at the interior lattice points by setting them to zero, or setting them to values that might approximate the solution. Then we systematically cycle through all the *interior* lattice points, replacing the old estimates with new ones calculated by the difference equation (6.12). We can cycle along rows or columns, but it is common to cycle row by row, from bottom to top. After a number of cycles, the estimates will converge to the solution of the linear system. One can terminate the iteration process when the change from one complete iteration to the next is small, measured in some manner. This process is extremely simple to program, and the cycling is accomplished in a few lines of code. Actually, there are several ways the iteration procedure can be accelerated, and we refer the reader to the references and the key words *successive overrelaxation* (SOR).

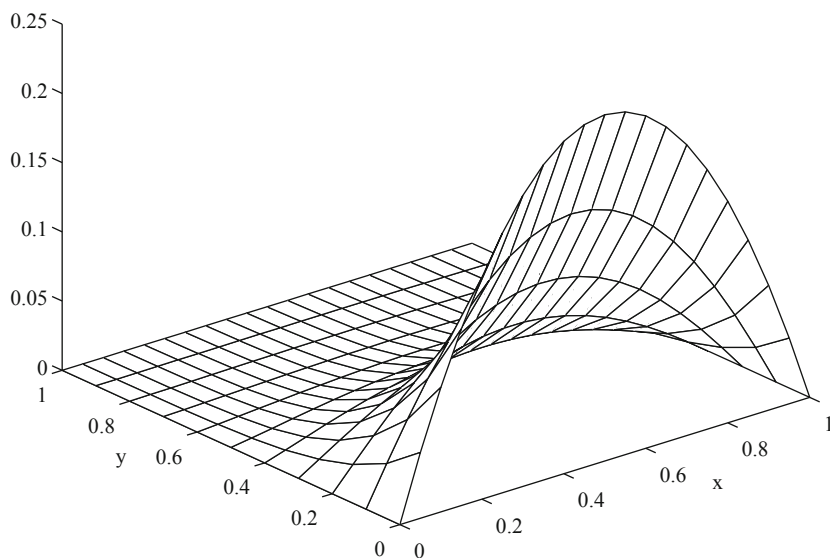

Figure 6.6 Solution to the BVP (6.9), (6.10), (6.11) for Laplace's equation when $f(x) = x(1 - x)$

Here is a basic outline of the Gauss–Seidel method. After putting in the prescribed values on the boundary and initializing the the array $U_{i,j}$ (to zero, say)

at the interior grid points, we perform the following row-by-row iteration using three nested loops:

```

for n from 1 to number of iterations;
for i from 1 to I-1;
for j from 1 to J-1;
U[i,j] =k^2/(2*k^2+2*h^2)*(U[i-1,j]+U[i+1,j])
+h^2/(2*k^2+2*h^2)*(U[i,j-1]+U[i,j+1]);
end; end; end;

```

The MATLAB code *Laplace* is at the end of the chapter. We take $I = 20$ and $J = 10$, giving $19 \times 9 = 171$ interior lattice points. Figure 6.6 shows the solution surface after 20 iterations through the grid.

Neumann and radiation boundary conditions can be handled similarly as in the heat and wave equations. See the Exercises.

EXERCISES

- In Example 6.5 write the linear system for the six unknowns $U_{i,j}$ in standard matrix form, $A\mathbf{x} = \mathbf{b}$, where \mathbf{x} is the column vector of unknowns, and A is the coefficient matrix. Note that A is a tridiagonal matrix.
- Write a finite difference code to solve the following steady-state problems:

$$\begin{aligned}
 u_{xx} + u_{yy} &= 0, & 0 < x < 2, & 0 < y < 1, \\
 u(0, y) &= 2 \sin \pi y, & u(2, y) &= 0, & 0 < y < 1, \\
 u(x, 0) &= x(2 - x), & u(x, 1) &= 0, & 0 < x < 2.
 \end{aligned}$$

b)

$$\begin{aligned}
 u_{xx} + u_{yy} &= 0, & 0 < x < 2, & 0 < y < 1, \\
 u_x(0, y) &= 0, & u(2, y) &= 0, & 0 < y < 1, \\
 u(x, 0) &= x(2 - x)^2, & u(x, 1) &= 0, & 0 < x < 2.
 \end{aligned}$$

To handle the insulated boundary condition at $x = 0$ in (b), use a forward difference approximation; note that you must calculate the solution along that boundary.

- Consider Laplace's equation on the triangle with vertices $(0, 0)$, $(1, 0)$, $(0, 1)$. Use a lattice with spacing $h = k = \frac{1}{6}$. If the oblique edge is insulated, find a difference approximation at a point (x_j, y_k) on that boundary. If the left

edge is held at 1 and the lower edge is held at 0, find the matrix equation for the unknown grid points. (Recall, the oblique boundary points must be calculated.)

6.4 Implicit Scheme for the Heat Equation

In an *explicit* difference scheme we compute a new time values of the grid function U_j^{n+1} explicitly only in terms of the previous time values U_j^n . As we found in the explicit method for the heat equation, we were forced to take very small time to insure stability. There are other difference schemes that are *implicit* in nature. In these we are not able to solve for a new time value explicitly, but rather we obtain a *system of algebraic equations* at the new time for all the values simultaneously. These methods typically have a strong advantage: they are stable without putting a constraint on the size of time step. A disadvantage is that coding such schemes is a little more difficult.

In this section we set up such a scheme for the heat equation. Consider the initial BVP problem for the heat, or diffusion, equation presented in Section 6.2:

$$u_t = Du_{xx}, \quad 0 < x < 1, \quad 0 < t < T, \quad (6.13)$$

$$u(0, t) = u(1, t) = 0, \quad t > 0, \quad (6.14)$$

$$u(x, 0) = f(x), \quad 0 < x < 1. \quad (6.15)$$

The first step to discretize, as before, the region of space-time where we want to obtain a solution. In this case the region is $0 \leq x \leq 1, 0 \leq t \leq T$. Therefore we define a **lattice** of points in this space-time region by

$$x_j = jh, \quad t_n = nk, \quad j = 0, 1, \dots, J; \quad n = 0, 1, \dots, N,$$

where the fixed numbers h and k are the spatial and temporal step sizes given by $h = 1/J$ and $k = 1/N$. For an implicit scheme we approximate the time derivative as before by a forward difference

$$u_t(x_j, t_n) = \frac{u(x_j, t_{n+1}) - u(x_j, t_n)}{k} + O(k).$$

But for the second spatial derivative u_{xx} at (x_j, t_n) , rather than a centered difference at time t_n , we take a *weighted average* of two centered difference approximations, one at t_n and one at t_{n+1} . Therefore,

$$\begin{aligned} u_{xx}(x_j, t_n) &= (1 - \theta) \frac{u(x_{j-1}, t_{n+1}) - 2u(x_j, t_{n+1}) + u(x_{j+1}, t_{n+1})}{h^2} \\ &+ \theta \frac{u(x_{j-1}, t_n) - 2u(x_j, t_n) + u(x_{j+1}, t_n)}{h^2} + O(h^2), \end{aligned}$$

where $0 \leq \theta \leq 1$. Therefore, the computational molecule is shown in Figure 6.7. Substituting these approximations into the PDE (6.13) using U_j^n as the

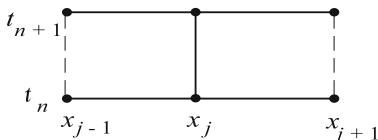

Figure 6.7 A six-node computational molecule for the implicit difference scheme

approximation for $u(x_j, t_n)$, we obtain the finite difference equation

$$\frac{U_j^{n+1} - U_j^n}{k} = D\theta \frac{U_{j-1}^{n+1} - 2U_j^{n+1} + U_{j+1}^{n+1}}{h^2} + D(1 - \theta) \frac{U_{j-1}^n - 2U_j^n + U_{j+1}^n}{h^2}.$$

We have dropped the truncation error terms. We rearrange the terms in this equation to obtain

$$\begin{aligned} -\theta r U_{j-1}^{n+1} + (1 + 2r\theta) U_j^{n+1} - \theta r U_{j+1}^{n+1} \\ = (1 - \theta) r U_{j-1}^n + [1 - 2(1 - \theta)r] U_j^n + (1 - \theta) r U_{j+1}^n, \end{aligned} \tag{6.16}$$

where

$$r = \frac{kD}{h^2}.$$

Notice that when $\theta = 0$ this scheme reduces to the classical explicit scheme; when $\theta = \frac{1}{2}$, the scheme is called the **Crank–Nicolson scheme**. We have written the three unknown values $U_{j-1}^{n+1}, U_j^{n+1}, U_{j+1}^{n+1}$ at the $(n + 1)$ st time level in terms of the three known values at the n th time level. For each fixed n , we have to solve this equation for $j = 1, 2, \dots, J - 1$. Therefore equation (6.16) represents a system of $J - 1$ equations for the $J - 1$ values $U_1^{n+1}, U_2^{n+1}, \dots, U_{J-1}^{n+1}$. Each equation has three unknowns. In matrix form (6.16) can be written as a tridiagonal system

$$\begin{pmatrix} 1 + 2r\theta & -r\theta & & & & \\ -r\theta & 1 + 2r\theta & -r\theta & & & \\ & -r\theta & 1 + 2r\theta & -r\theta & & \\ & & \dots & \dots & & \\ & & & \dots & -r\theta & \\ & & & -r\theta & 1 + 2r\theta & \end{pmatrix} \begin{pmatrix} U_1^{n+1} \\ U_2^{n+1} \\ U_3^{n+1} \\ \dots \\ U_{J-2}^{n+1} \\ U_{J-1}^{n+1} \end{pmatrix} = \begin{pmatrix} F_1^n \\ F_2^n \\ F_3^n \\ \dots \\ F_{J-2}^n \\ F_{J-1}^n \end{pmatrix}$$

where the right side involves the terms on the right of (6.16) and the boundary conditions. This system must be solved at each time step, but there are

no constraints on the time step as in explicit methods. This scheme is stable unconditionally. As it turns out, there are simple direct algorithms to solve tridiagonal systems (see the references, MATLAB manuals, or other computer algebra systems). In addition, there are iterative methods similar to the Gauss–Seidel method that can be applied at each time step to solve the system.

EXERCISES

1. Use the Crank–Nicolson scheme with $\theta = 0.5$, $D = 1$, $h = 0.2$, $k = 0.08$ and write out the scheme (6.16) for $n = 0$ when the initial condition (6.15) is given by $f(x) = x(1 - x)$. Write the tridiagonal system explicitly (there are four unknowns) and solve it to find the solution at the time line $n = 1$.
2. Use the Crank–Nicolson scheme to numerically solve the problem

$$\begin{aligned} u_t &= u_{xx} + u, & 0 < x < 1, t > 0, \\ u(0, t) &= u(1, t) = 0, & t > 0, \\ u(x, 0) &= 1, & 0 \leq x \leq 1. \end{aligned}$$

Take $h = k = 0.2$.

3. Consider the BVP for the advection equation

$$u_t + cu_x = 0, \quad x \in \mathbb{R}, \quad (c > 0),$$

with $u(x, 0) = f(x)$, $x \geq 0$, $u(0, t) = g(t)$, $t > 0$.

- a) Using the three-point molecule (x_j, t_n) , (x_{j-1}, t_{n+1}) , (x_j, t_{n+1}) , derive the implicit difference equation approximation

$$(1 + s)U_j^{n+1} - sU_{j-1}^{n+1} = U_j^n, \quad s = \frac{ch}{k}.$$

- b) Show that the scheme is von Neumann stable.
- c) Develop an algorithm to compute U_j^n at lattice points in the first quadrant. Explain carefully your procedure.

MATLAB Program Listings

Programming note: MATLAB, like other computer algebra systems, does not recognize an index with value 0. Many of the formulas in the text require, for example, ranges such as $j = 0, 1, 2, \dots, J$. For MATLAB expressions we must shift the indices and use $j = 1, 2, \dots, J + 1$. This is an unfortunate nuisance in writing programs.

```
function EulerMethod
f=@(t,Y) -0.1*(Y-(15+12*cos(3.14*t/12)))
t0=0; Y0=68; T=72; N=1000; h=(T-t0)/N; Y=zeros(N+1); Y(1)=Y0;
for n=1:N
    t(n) = a+(n-1)*h;
    Y(n+1) = Y(n)+h*f(t(n),Y(n));
end
t=t0:h:T; plot(t,Y), xlabel('time in hours'),
    ylabel('temperature Y in deg F'),
ylim([0 70]), title('Newton Law of Cooling')
```

```
function ExplicitHeat
xmax=1; J=20; h=xmax/J; tmax=2; N=50; k=tmax/N;
D=0.02; r=D*k/(h*h)
U=zeros(J+1,N+1);
f=@(x) x.^3. x*(1-x);
for j=1:J+1; U(j,1)=f((j-1)*h); end
for n=1:N+1; U(1,n)=0; U(J+1,n)=0; end
for n=1:N
    for j=2:J
        U(j,n+1)=U(j,n)+r*(U(j-1,n)-2*U(j,n)+U(j+1,n));
    end
end
[T,X]=meshgrid(0:h:xmax,0:k:tmax);
mesh(X,'T',U,'EdgeColor','black')
xlabel('t','FontSize',14),ylabel('x','FontSize',14)
title('Explicit Scheme for Heat Equation')
```

```
function Laplace
% Gauss--Seidel method
xmax=1; ymax=1;
I=20; J=10; h=1/I; k=1/J; Numit=20;
r=0.5*k^2/(k^2+h^2); s=0.5*h^2/(k^2+h^2);
U=zeros(I+1,J+1);
f=@(x) x * (1-x);
for i=1:I+1; U(i,1)=f((i-1)*h); end
for i=1:I+1; U(i,J+1)=0; end
for j=2:J; U(1,j)=0; end
for j=2:J; U(I+1,j)=0; end
for n=1:Numit
    for i=2:I
        for j=2:J
            U(i,j)=r*(U(i-1,j)+U(i+1,j))+s*(U(i,j-1)+U(i,j+1));
        end
    end
end
[X,Y]=meshgrid(0:h:xmax,0:k:ymax);
mesh(X',Y',U,'EdgeColor','black')
xlabel('x','FontSize',14),ylabel('y','FontSize',14)
```

A

Differential Equations

PDEs are frequently solved by reducing them to one or more ODEs. This appendix contains a brief review of how to solve some of the basic ODEs encountered in this book.

For notation, we let $y = y(x)$ be the unknown function. Derivatives will be denoted by primes, i.e., $y' = y'(x)$, $y'' = y''(x)$. Sometimes we use the differential notation $y' = \frac{dy}{dx}$. If f is a function, an **antiderivative** is defined as a function F whose derivative is f , i.e., $F'(x) = f(x)$. Antiderivatives are unique only up to an additive constant, and they are often denoted by the usual indefinite integral sign:

$$F(x) = \int f(x)dx + C.$$

An arbitrary constant of integration C is added to the right side. However, in this last expression, it is often impossible to evaluate the antiderivative F at a particular value of x because the indefinite integral cannot be found in terms of familiar functions. (Take, for example, $f(x) = e^{-x^2}$.) In this case we must use the *general form of the antiderivative* as a definite integral with a variable upper limit,

$$F(x) = \int_a^x f(s)ds + C,$$

where a is any constant (observe that a and C are not independent, since changing one changes the other). If f is continuous at x , by the fundamental theorem of calculus, $F'(x) = f(x)$.

First-Order Equations

An ODE of the first order is an equation of the form

$$G(x, y, y') = 0 \quad \text{or} \quad y' = F(x, y).$$

There are three types of equations that occur regularly in PDEs: separable, linear, and Bernoulli. The general solution involves an arbitrary constant C that can be determined by an initial condition of the form $y(x_0) = y_0$.

Separable Equations. A first-order equation is separable if it can be written in the form

$$\frac{dy}{dx} = f(x)g(y).$$

In this case we separate variables and write

$$\frac{dy}{g(y)} = f(x)dx.$$

Integrating both sides gives

$$\int \frac{dy}{g(y)} = \int f(x)dx + C,$$

which defines the solution implicitly. As noted above, sometimes the antiderivatives must be written as definite integrals with a variable upper limit of integration.

Linear Equations. A first-order linear equation is one of the form

$$y' + p(x)y = q(x).$$

This can be solved by multiplying both sides by an *integrating factor* of the form

$$P(x) = e^{\int_a^x p(s)ds}.$$

This transforms the left side of the equation into a total derivative, and it becomes

$$\frac{d}{dx} (P(x)y) = P(x)q(x).$$

Now, both sides can be integrated from a to x to find y .

For example, to find an expression for the solution to the initial value problem

$$y' + 2xy = \sqrt{x}, \quad y(0) = 3,$$

We note that the integrating factor is

$$P(x) = \exp\left(\int_0^x 2s ds\right) = e^{x^2}.$$

Multiplying both sides of the equation by the integrating factor gives

$$\left(ye^{x^2}\right)' = \sqrt{x}e^{x^2}.$$

Now, integrating from 0 to x (while changing the dummy variable of integration to s) gives

$$y(x)e^{x^2} - y(0) = \int_0^x \sqrt{s}e^{s^2} ds.$$

Solving for y gives

$$y(x) = e^{-x^2} \left(3 + \int_0^x \sqrt{s}e^{s^2} ds \right) = 3e^{-x^2} + \int_0^x \sqrt{s}e^{s^2-x^2} ds.$$

Bernoulli Equations. Bernoulli equations are nonlinear equations having the form

$$y' + p(x)y = q(x)y^n.$$

The transformation of dependent variables $w = y^{1-n}$ transforms a Bernoulli equation into a first-order linear equation for w .

Second-Order Equations

Constant-Coefficient Equations. The linear equation

$$ay'' + by' + cy = 0,$$

where a, b , and c are constants, occurs frequently in applications. We recall that the general solution of a linear, second-order, homogeneous equation is a linear combination of two independent solutions. That is, if $y_1(x)$ and $y_2(x)$ are independent solutions, then the general solution is

$$y = c_1y_1(x) + c_2y_2(x),$$

where c_1 and c_2 are arbitrary constants. If we try a solution of the form $y = e^{mx}$, where m is to be determined, then substitution into the equation gives the so-called *characteristic equation*

$$am^2 + bm + c = 0$$

for m . This is a quadratic polynomial that will have two roots, m_1 and m_2 , called *eigenvalues*. Three possibilities can occur: unequal real roots, equal real roots, and complex roots (which must be complex conjugates).

Case (I). m_1, m_2 real and unequal. In this case two independent solutions are

$$y_1 = e^{m_1x} \quad y_2 = e^{m_2x}.$$

Case (II). m_1, m_2 real and equal, i.e., $m_1 = m_2 \equiv m$. In this case two independent solutions are

$$y_1 = e^{mx} \quad y_2 = xe^{mx}.$$

Case (III). $m_1 = \alpha + i\beta, m_2 = \alpha - i\beta$ are complex conjugate roots. In this case two real, independent solutions are

$$y_1 = e^{\alpha x} \sin \beta x \quad y_2 = e^{\alpha x} \cos \beta x.$$

Of particular importance are the two equations

$$y'' + a^2y = 0, \quad y'' - a^2y = 0$$

which have general solutions

$$y(x) = c_1 \cos ax + c_2 \sin ax, \quad y = c_1 e^{-ax} + c_2 e^{ax},$$

respectively. Equivalently, this second solution can be written

$$y = c_1 \cosh ax + c_2 \sinh ax.$$

These equations occur so frequently that it is best to memorize their solutions.

Cauchy–Euler Equations. It is difficult to solve second-order linear equations with variable coefficients. The reader may recall power series methods are generally applied. However, there is a special equation that can be solved with a simple formula, namely, a Cauchy–Euler equation of the form

$$ax^2y'' + bxy' + cy = 0.$$

This equation admits power functions as solutions. Hence, if we try a solution of the form $y = x^m$, where m is to be determined, then we obtain upon substitution the characteristic equation

$$am(m-1) + bm + c = 0.$$

This quadratic equation has two roots, m_1 and m_2 . Thus, there are three cases:

Case (I). m_1, m_2 real and unequal. In this case two independent solutions are

$$y_1 = x^{m_1} \quad \text{and} \quad y_2 = x^{m_2}.$$

Case (II). m_1, m_2 real and equal, i.e., $m_1 = m_2 \equiv m$. In this case two independent solutions are

$$y_1 = x^m \quad \text{and} \quad y_2 = x^m \ln x.$$

Case (III). $m_1 = \alpha + i\beta, m_2 = \alpha - i\beta$ are complex conjugate roots. In this case two real, independent solutions are

$$y_1 = x^\alpha \sin(\beta \ln x) \quad \text{and} \quad y_2 = x^\alpha \cos(\beta \ln x).$$

Particular Solutions

The general solution of the nonhomogeneous equation

$$y'' + p(x)y' + q(x)y = f(x)$$

is

$$y = c_1 y_1(x) + c_2 y_2(x) + y_P(x),$$

where y_1 and y_2 are independent solutions of the homogeneous equation (when $f(x) \equiv 0$), and $y_P(x)$ is any particular solution to the inhomogeneous equation. For constant-coefficient equations a particular solution can sometimes be found by judiciously ‘guessing’ the form from the form of $f(x)$; this method is called the method of *undetermined coefficients*. In all cases, however, there is a general formula, called the *variation of parameters* formula, which gives the particular solution in terms of the two linearly independent solutions y_1 and y_2 of the homogeneous equation. The formula, which is derived in elementary texts, is given by

$$y_P(x) = y_2(x) \int_a^x \frac{y_1(s)f(s)}{W(s)} ds - y_1(x) \int_a^x \frac{y_2(s)f(s)}{W(s)} ds,$$

where

$$W(x) = y_1(x)y_2'(x) - y_2(x)y_1'(x)$$

is the *Wronskian*.

There are several introductory texts on differential equations. A classic text is Boyce and DiPrima (1995), as well as later editions. Birkhoff and Rota (1978) and Kelley and Peterson (2004) are two more advanced texts.

References

- Birkhoff, G., & Rota, J.-C. (1989). *Ordinary differential equations* (4th ed.). NY: Wiley.
- Boyce, W. E., & DiPrima, R. C. (1995). *Elementary differential equations* (5th ed.). NY: Wiley.
- Britton, N. F. (2003). *Essential mathematical biology*. NY: Springer.
- Chorin, A. J., & Marsden, J. E. (1993). *A mathematical introduction to fluid mechanics* (3rd ed.). NY: Springer.
- Churchill, R. V. (1960). *Complex variables and applications* (2nd ed.). NY: McGraw-Hill.
- Churchill, R. V. (1969). *Fourier series and boundary value problems* (2nd ed.). NY: McGraw-Hill.
- Churchill, R. V. (1972). *Operational mathematics* (3rd ed.). NY: McGraw-Hill.
- Debnath, L. (1997). *Nonlinear partial differential equations*. Boston: Birkhauser.
- Edelstein-Keshet, L. (1989). *Mathematical models in biology*. NY: McGraw-Hill.
- Farlow, S. J. (1993). *Partial differential equations for scientists and engineers*. NY: Dover Publications.
- Fetter, C. W. (1993). *Contaminant hydrogeology*. NY: Macmillan.
- Griffiths, D. J. (2005). *Introduction to quantum mechanics*. Englewood Cliffs: Pearson Prentice-Hall.
- Haberman, R. (2013). *Applied partial differential equations* (5th ed.). Upper Saddle River: Pearson.
- Holmes, M. H. (2007). *Introduction to numerical methods in differential equations*. NY: Springer.

- Holmes, M. H. (2009). *Introduction to the foundations of applied mathematics*. NY: Springer.
- Hughes-Hallet, D., et al. (2013). *Calculus* (6th ed.). Hoboken: Wiley.
- Kelley, W., & Peterson, A. (2004). *The theory of differential equations*. Upper Saddle River: Pearson Education.
- Kot, M. (2001). *Elements of mathematical ecology*. Cambridge: Cambridge University Press.
- Lin, C. C., & Segel, L. A. (1989). *Mathematics applied to deterministic models in the natural sciences*, reprinted by Soc. Appl. and Industr. Math. (SIAM), Philadelphia.
- Logan, J. D. (1987). *Applied mathematics: A contemporary approach*. NY: Wiley-Interscience. (See Chapter 8 on finite difference methods.)
- Logan, J. D. (2001). *Transport modeling in hydrogeochemical systems*. NY: Springer.
- Logan, J. D. (2009). *Introduction to nonlinear partial differential equations* (2nd ed.). NY: Wiley-Interscience.
- Logan, J. D. (2015). *A first course in differential equations* (3rd ed.). NY: Springer.
- Logan, J. D. (2013). *Applied mathematics: Fourth edition*. Hoboken: Wiley.
- Logan, J. D., & Wolesensky, W. R. (2008). *Mathematical methods in biology*. Hoboken: Wiley.
- McOwen, R. C. (2003). *Partial differential equations* (2nd ed.). Upper Saddle River: Prentice-Hall.
- Murray, J. D. (2003). *Mathematical biology* (Vol. II). NY: Springer.
- Parker, D. F. (2003). *Fields, flows, and waves*. NY: Springer.
- Segel, L. A., & Handelman, G. H. (1977). *Mathematics applied to continuum mechanics*. NY: Macmillan. (Reprinted by Dover Publications, NY, 1987).
- Smith, G. D. (1978). *Numerical solution of partial differential equations: Finite difference methods* (2nd ed.). Oxford: Oxford University Press.
- Spivak, M. (2008). *Calculus* (4th ed.). Houston: Publish or Perish.
- Strauss, W. (1992). *Introduction to partial differential equations*. NY: Wiley.
- Vretblad, A. (2006). *Fourier analysis and its applications*. NY: Springer.

- L^2 convergence, 137
- acoustic approximation, 54
- acoustics, 52
- adjoint
 - formal, 185
- advection, 14, 40
- advection-decay, 15
- age of the earth, 100
- age-structured model, 229
- Airy function, 124
- aquifer, 32

- Bernoulli equation, 281
- Bessel’s equation, 183
- Bessel’s inequality, 141
- best approximation in L^2 , 140
- boundary condition, 4
- Burgers equation, 38

- Cauchy problem, 80, 87
- Cauchy–Euler equation, 282
- Cauchy–Schwarz inequality, 144
- cell aggregation, 249
- CFL condition, 266
- characteristic coordinates, 16
- characteristics, 20, 89
- chemotaxis, 250
- complete orthonormal system, 142
- conservation law, 12, 14
- constitutive equation, 14
- convergence of series, 136
- convolution theorem, 108
 - Fourier transforms, 120
- cooling of a sphere, 198
- Crank–Nicolson scheme, 274

- d’Alembert’s formula, 87
- diffusion, 29, 40
- diffusivity, 63
- Dirichlet condition, 63
- Dirichlet problem, 193
- Dirichlet’s principle, 65, 194
- discriminant, 73
- dispersion, 124
- dispersion relation, 11
- divergence theorem, 61, 62, 191
- domain of dependence, 89
- Duhamel’s principle, 102, 209

- eigenfunction, 158
- eigenfunction method
 - sources, 210
- eigenvalue, 158
- eigenvalue problem, 168
- eigenvalues
 - the Laplacian, 217
- elliptic, 73
- energy argument, 173, 194
- energy integral, 194
- energy spectrum, 142
- epidemic waves, 241
- equation of state, 53
- erf function, 82
- erfc function, 110
- Euler’s method, 258

- Euler–Lotka equation, 232
 evolution equation, 4
 exterior Dirichlet problem, 191
- Fick’s law, 29
 Fisher’s equation, 40, 254
 Fourier coefficients, 139
 Fourier cosine series, 143, 148
 Fourier integral theorem, 118
 Fourier series, 145
 - exponential form, 151
 - pointwise convergence, 152
 - uniform convergence, 152
 Fourier sine series, 135, 145, 148
 Fourier sine transform, 184
 Fourier transform, 117
 Fourier’s law, 31
 Fourier’s method, 130
 Fredholm alternative, 222
 frequency spectrum, 119
 function space, 134
 fundamental frequencies, 56
 fundamental modes, 56
- gas dynamics, 53
 Gauss–Seidel method, 271
 Gaussian function, 118
 generalized Fourier series, 139
 Gibbs phenomenon, 154
 Gram–Schmidt orthogonalization, 144
 Green’s function, 85, 162, 221
 - infinite domain, 222
 Green’s identity, 65, 170
 Green’s second identity, 193
- harmonic functions, 187
 heat conduction
 - higher dimensions, 60
 heat equation, 3, 31, 63
 - Fourier transforms, 121
 heat flow in a disk, 187
 heat kernel, 83
 hyperbolic, 73
- implicit scheme
 - heat equation, 273
 initial condition, 4
 inner product, 133
 integration by parts, 226
 inverse problems, 112
- Lagrange’s identity, 170
 Laplace transform, 106
 - inversion, 107
 Laplace’s equation, 63, 186
 Laplacian, 62
 - cylindrical coordinates, 69
 - polar coordinates, 69
 - spherical coordinates, 70
 Lax–Wendroff method, 268
 Legendre polynomials, 144
 Legendre’s differential equation, 226
 Leibniz rule, 10
 linearization, 246
 logistic model, 39
- mass balance, 53
 mathematical model, 2
 maximum principle, 67
 McKendrick–von Forester equation, 230
 mean-square convergence, 137
 method of characteristics, 17
 method of images, 224
 method of moments, 234
 momentum balance law, 53
- nerve impulses on axons, 125
 Neumann condition, 63
 nonhomogeneous equations, 207
 nonlocal boundary condition, 231
 norm of a function, 134
 normal derivative, 64
- orthogonal, 135
 orthonormal, 135
- parabolic, 73
 parameter identification, 112, 125, 186
 Parseval’s equality, 142
 particular solutions, 283
 periodic boundary conditions, 172, 180
 periodic function, 148
 perturbation equation, 246
 pi theorem, 80
 plane wave, 11
 pointwise convergence, 136
 Poisson integral representation, 85
 Poisson’s equation, 63
 Poisson’s integral formula, 190
 potential function, 187
- quantum mechanics, 57
- radiation condition, 64
 rapidly decreasing functions, 117
 Rayleigh quotient, 174
 reaction–advection–dispersion, 33
 reaction–diffusion equations, 42

- reaction-advection, 17
- region of influence, 89
- renewal equation, 232

- Schrödinger equation, 57
- Schwartz class, 117
- self-adjoint, 177
- semi-infinite domain, 96
- separation of variables, 156
- signaling problem, 91
- singular SLPs, 182
- solution, 7
- sound speed, 54
- source function, 162
- spatial patterns, 245
- square integrable, 133
- stability, 93
- stable age structure, 231
- standing wave, 56
- steady-state, 34
- Sturm–Liouville problem, 167
- subsurface temperatures, 100
- superposition, 6

- survivorship function, 232
- symmetric boundary conditions, 177

- Taylor’s theorem, 258
- telegraph equation, 56
- time scale: diffusion, 31
- traffic flow, 24
- transmission line, 56
- traveling waves, 238
- trigonometric series, 145
- Turing system, 253

- uniform convergence, 137

- variation of parameters, 104, 283
- von Neumann stability analysis, 263

- wave equation, 52, 54
 - damped, 55
- wave front solution, 239
- well-posed, 34
- well-posed problem, 93