

# BRINK

**BOOK ONE**

**DAN ABNETT ★ I.N.J. CULBARD**

**DAN ABNETT**

Writer

**I.N.J. CULBARD**

Artist

**I.N.J. CULBARD**

Cover Artist

**REBELLION<sup>®</sup>**

Creative Director and CEO: Jason Kingsley

Chief Technical Officer: Chris Kingsley

Head of Books & Comics: Ben Smith

*2000 AD* Editor in Chief: Matt Smith

Senior Graphic Novel Editor: Keith Richardson

Junior Graphic Novel Editor: Oliver Ball

Graphic Design: Sam Gretton, Oz Osborne & Maz Smith

Reprographics: Joseph Morgan

PR: Michael Molcher

Original Commissioning Editor: Matt Smith

Originally serialised in *2000 AD Progs* 1978-1992. Copyright © 2017 Rebellion A/S. All Rights Reserved. *Brink* and all related characters, their distinctive likenesses and related elements featured in this publication are trademarks of Rebellion A/S. *2000 AD* is a registered trademark. The stories, characters and incidents featured in this publication are entirely fictional.

Published by Rebellion, Riverside House, Osney Mead, Oxford, OX2 0ES, UK

[www.rebellion.co.uk](http://www.rebellion.co.uk)

ISBN: 978-1-78108-550-9

Printed in the UK

Manufactured in the EU by Stanton Book Services,  
Wellingborough NN8 3PJ, UK.

1st Printing: September 2017

10 9 8 7 6 5 4 3 2 1

For information on other *2000 AD* graphic novels, or if you have any comments on this book, please email [books@2000ADonline.com](mailto:books@2000ADonline.com)

To find out more about *2000 AD*, visit [www.2000ADonline.com](http://www.2000ADonline.com)



# BRINK

**BOOK ONE**

BRINK CREATED BY DAN ABNETT & I.N.J. CULBARD



## Sometimes, it's not entirely clear where an idea comes from.

I first worked with Ian Culbard on *The New Deadwardians*, a series for DC Vertigo that I had devised. I knew and admired his work, and suggested him as artist. Even though the story was mapped out before he arrived, it developed as we got chatting. We began long, regular conversations and, if nothing else, they established a degree of understanding, so I quickly knew how much (or little) to give him in a script, and he knew what I was looking for in his art.

We've since collaborated on a number of different projects, most notably *Wild's End* for Boom! The one thing they've all had in common is that the ideas have been ours. They've grown from conversations. They've all been original to us, even if we can't precisely say how they formed.

As we were both long-time contributors to *2000 AD*, it seemed appropriate for us to produce a series for the Mighty Tharg together. That series was *Brink*, the first volume of which is contained in this book. It's full on space-set SF, which was a change of pace for us, but it's also a horror story, a police procedural, and a mystery. That particular cocktail was again the product of our conversations. One moment, we were rambling, and the next we exclaimed, 'That's it! That's the idea!'

*Brink* was very well received by the readers. Apart from the obvious pleasures of Ian's distinctive art work and brilliant storytelling, readers seemed to enjoy the story method itself. It's character-driven and carried by



dialogue. There is no narration. Information is delivered via 'tags' that work like footnotes to fill in raw exposition. This meant the dialogue could be extremely conversational and naturalistic. It's (deceptively) slow-burn, and paced unlike other *2000 AD* stories. It's also nothing like anything else I've written.

You're about to read it, so no spoilers, but I will say that there's a twisting of comprehension as the characters gradually, creepily, realise that ideas have permeated their world that make no sense on the surface yet seem to be true and real. Life for these humans living on the 'Brink' - artificial stations and habitats to which they have been exiled following the death of Earth - is slowly

becoming unzipped. It is a genuine otherness, or simply a psychological breakdown triggered by this remote, unforgiving, castaway life?

The mystery underpinning the drama is... where are these ideas coming from?

And, as I mentioned at the start, that's not always easy to figure out.

**Dan Abnett**

Somewhere on the brink,  
March 2017



# BOOK ONE

Script: DAN ABNETT  
Art: I.N.J. CULBARD  
Letters: SIMON BOWLAND

Originally published in 2000 AD Progs 1978-1992

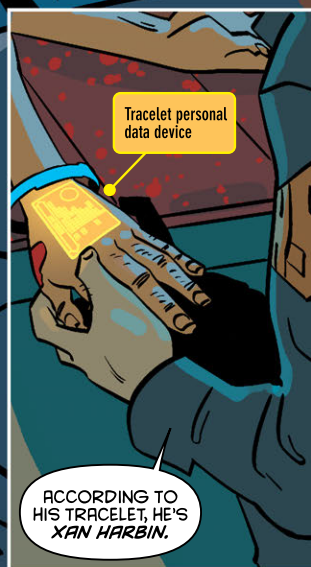
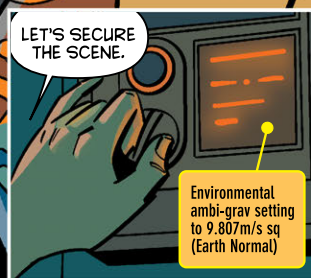

"NOT THESE DAYS."

Odette Habitat  
Owned: Sugarsurf Pharma  
Completed: 2076 AD

Population: 209,000  
First occupied 2077,  
five years after the final  
evacuation of Earth

Habitation  
compartment 412  
Loop 343  
Odette

CHECK THE  
LOCKERS.

Carl Brinkmann  
Investigator, Habitat  
Security Division  
born: Xiang Habitat  
2061

Bridget Kurtis  
Investigator, Habitat  
Security Division  
born: Salma Habitat  
2067

HARBIN WAS  
ON DOUBLE-  
SCRIP NUDGE.

High-dose selective serotonin  
reuptake inhibitor antidepressants

...THAT  
CRACKWIDE  
CRUZ DONE  
NOW?

I TOLD  
HIM TO BE  
CHILL.

OH, FOR  
CRAP'S  
SAKE.

WE'RE GONNA  
NEED SHEET  
WRAP AND  
ACCESS TO THE  
WASTE PLANT--

FREEZE.  
SECURITY.

SHIT!

.40 SIGlock automatic,  
H.S.D. field issue  
flatnose rounds



DOWN!  
DOWN! GET  
DOWN!

GET  
THE OTHER  
ONE!

SHIT! NO!  
SHIT!



HALT!

DAMN IT.



QUIT IT!  
YOU'RE  
UNDER  
ARREST!

THIS AIN'T THE  
WAY! THIS AIN'T  
THE WAY!

THE LEPER HEART  
WILL SEE YOU FOR  
WHAT YOU ARE! SEE  
YOUR DISRESPECT!  
SEE YOUR BRUISES  
UPON MY BODY!

SHUT  
UP!

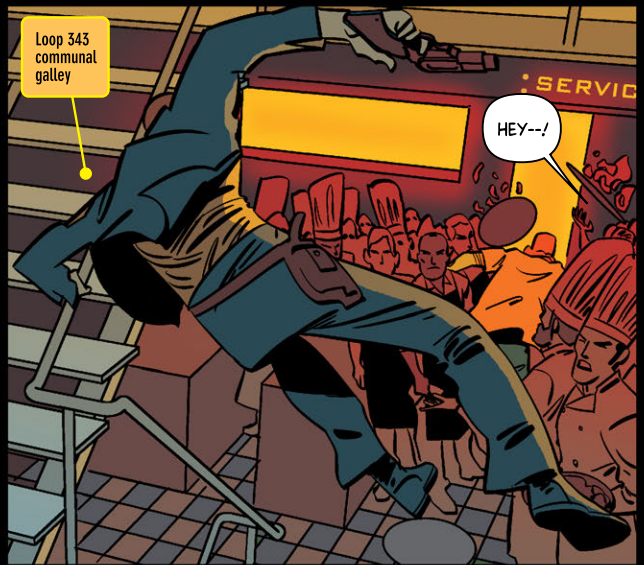

Loop 343  
communal  
galley

HEY--!



SECURITY!

MOVE  
ASIDE!

COME  
ON!



PROMISES WERE  
MADE! YOU'RE  
SPOILING IT!  
THE LEPER HEART  
PROMISED!

TOOK THE SOIL AND  
THE AIR, AND LEFT US IN THE  
DARK WITH A PROMISE IT  
WOULD COME BACK FOR  
US TOO!

SHUT THE  
HELL UP!

SWELLING UP,  
SWELLING UP OUT  
OF THE UNREACH,  
KEEPING ITS  
WHISPERED  
PROMISES!

LOW THETA,  
HANGING INSIDE  
THE SUN,  
MELANCHOLEMA,  
AND PHALE  
CHRONOZON--



Loop 343/Loop 344 junction ring





AAAHH!



UHNN!



MMMLL KRRMMNZZNNN!

SON OF A--



BDAM



JESUS.

THANKS.

YOU GOING TO BE SICK NOW?



NO.

NOTHING LEFT TO COME UP.

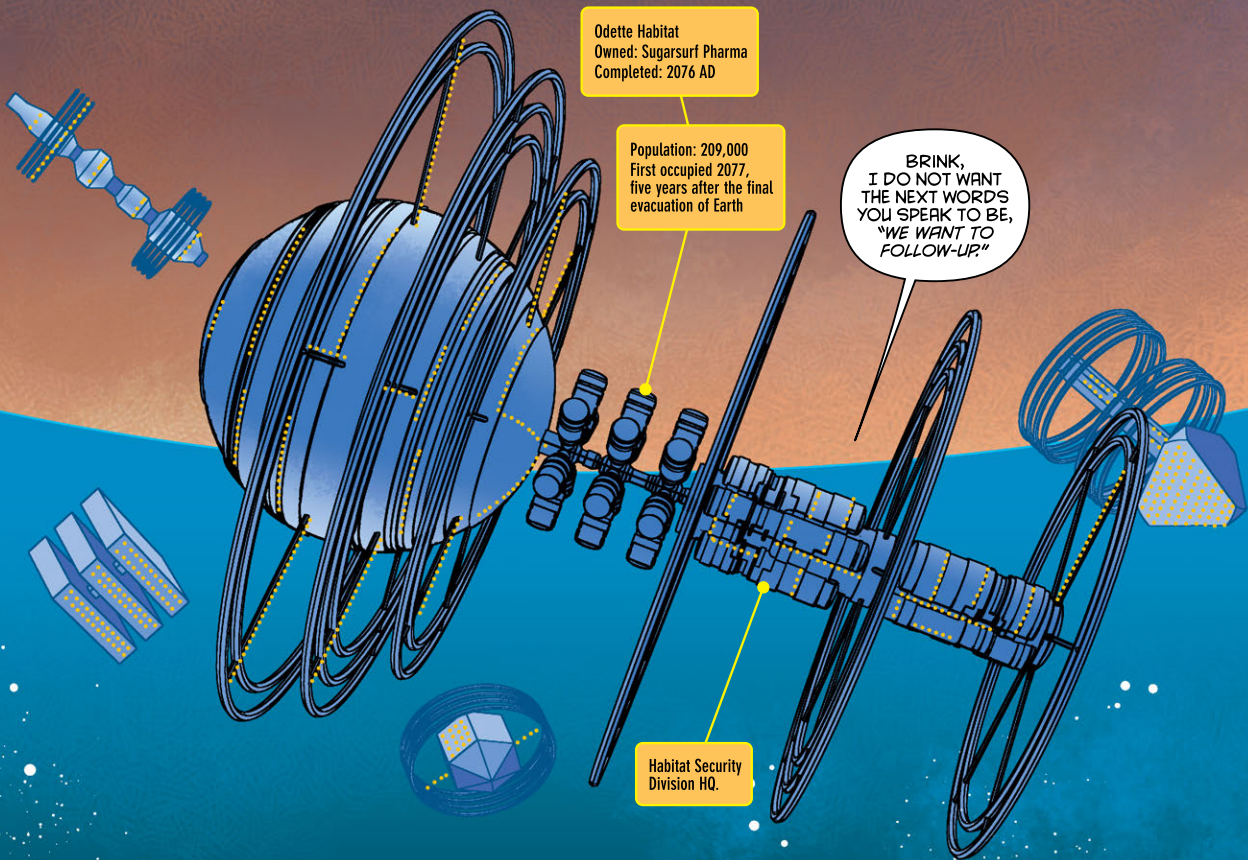



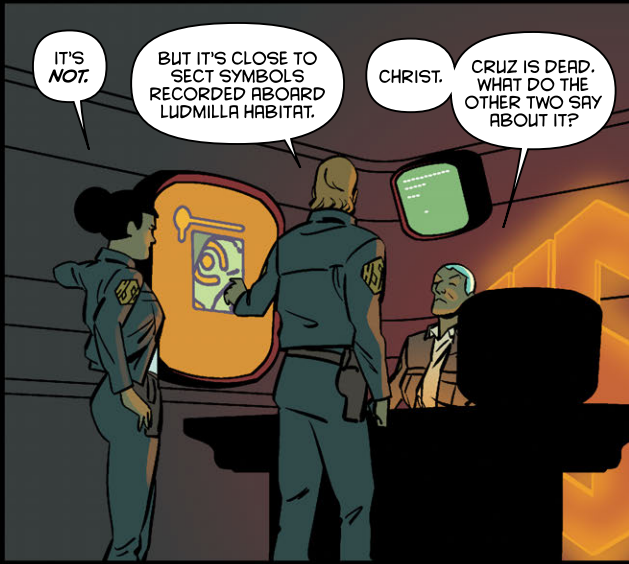

IT'S NOT.

BUT IT'S CLOSE TO SECT SYMBOLS RECORDED ABOARD LUDMILLA HABITAT.

CHRIST.

CRUZ IS DEAD. WHAT DO THE OTHER TWO SAY ABOUT IT?

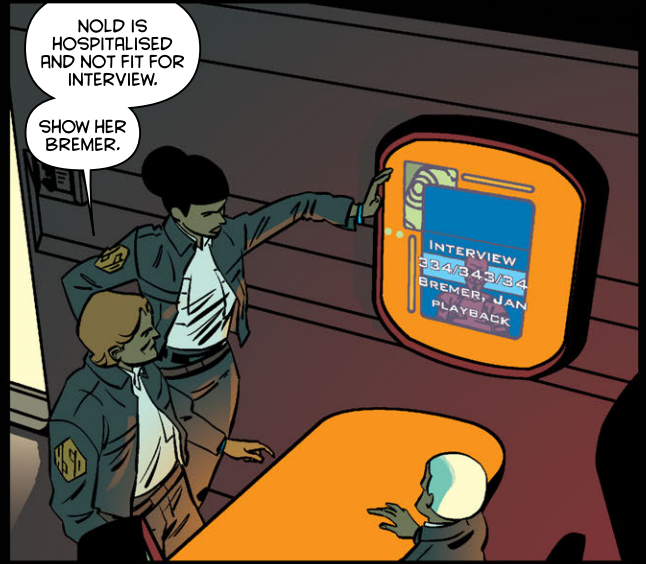

NOLD IS HOSPITALISED AND NOT FIT FOR INTERVIEW.

SHOW HER BREMER.

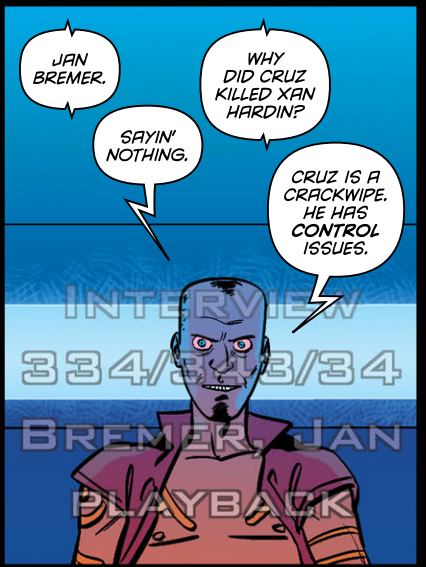

JAN BREMER.

SAYIN' NOTHING.

WHY DID CRUZ KILLED XAN HARDIN?

CRUZ IS A CRACKWIPE. HE HAS CONTROL ISSUES.



WAS. HAD.

WHATEVER. I TOLD HIM TO CHILL, BUT HE HAD IT IN FOR THAT HARDIN ASSHOLE. CREEP KEPT COMPLAINING ABOUT THINGS.

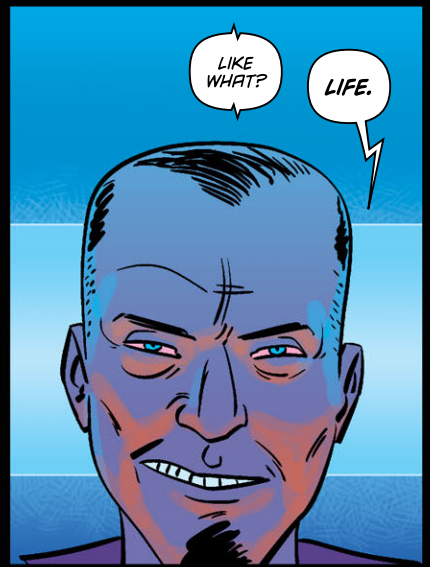

LIKE WHAT?

LIFE.

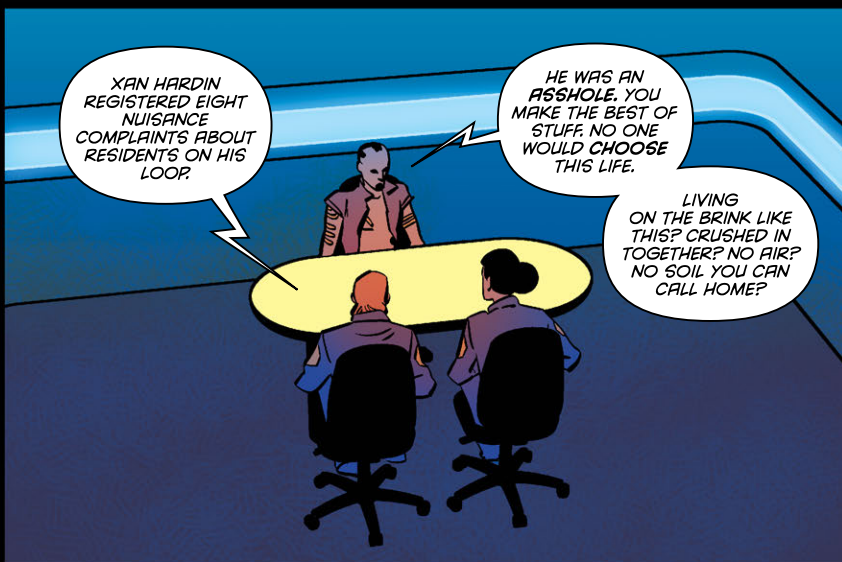

XAN HARDIN REGISTERED EIGHT NUISANCE COMPLAINTS ABOUT RESIDENTS ON HIS LOOP.

HE WAS AN ASSHOLE. YOU MAKE THE BEST OF STUFF. NO ONE WOULD CHOOSE THIS LIFE.

LIVING ON THE BRINK LIKE THIS? CRUSHED IN TOGETHER? NO AIR? NO SOIL YOU CAN CALL HOME?



NO ONE HAS IT EASY.

YOU MAKE THE BEST OF IT. CELEBRATE THE NOW. LOOK TO THE FUTURE.

AND HARDIN DIDN'T DO THAT?



HE COMPLAINED ABOUT THE NOISE.

HE DIDN'T EMBRACE THE FUTURE WITH YOU?

WE ASKED HIM. HE DIDN'T WANNA.



SO YOU KILLED HIM BECAUSE HE DIDN'T PARTY WITH YOU?

I DIDN'T KILL NO ONE. CRUZ DID.



WHAT DOES THE FUTURE MEAN TO YOU?

OH, SEE, NOW YOU'RE DISRESPECTING ME. THAT AIN'T THE WAY.

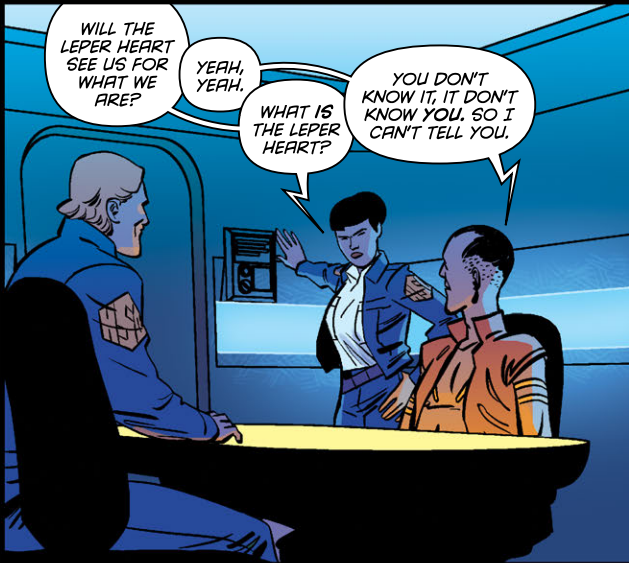

WILL THE LEPER HEART SEE US FOR WHAT WE ARE?

YEAH, YEAH.

WHAT IS THE LEPER HEART?

YOU DON'T KNOW IT, IT DON'T KNOW YOU, SO I CAN'T TELL YOU.

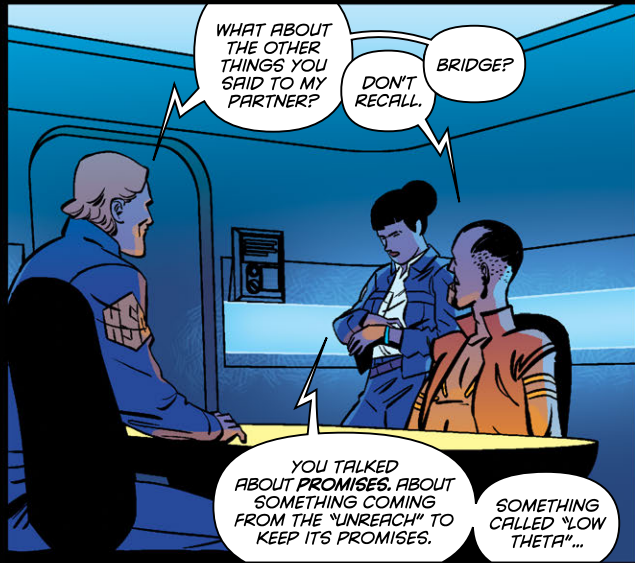

WHAT ABOUT THE OTHER THINGS YOU SAID TO MY PARTNER?

DON'T RECALL.

BRIDGE?

YOU TALKED ABOUT PROMISES. ABOUT SOMETHING COMING FROM THE "UNREACH" TO KEEP ITS PROMISES.

SOMETHING CALLED "LOW THETA"...



LOW THETA HANGS IN THE SUN.

EVERYONE KNOWS.

"MELAN-CHOLEMA."

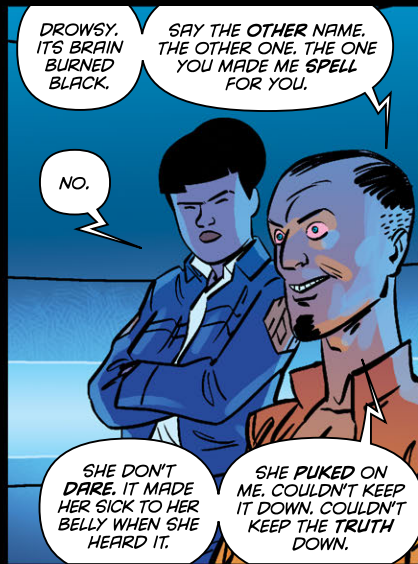

DROWSY. ITS BRAIN BURNED BLACK.

SAY THE OTHER NAME. THE OTHER ONE. THE ONE YOU MADE ME SPELL FOR YOU.

NO.

SHE DON'T DARE. IT MADE HER SICK TO HER BELLY WHEN SHE HEARD IT.

SHE PUKED ON ME. COULDN'T KEEP IT DOWN. COULDN'T KEEP THE TRUTH DOWN.



DO YOU BELONG TO A SECT, MR BREMER?

DISRESPECT.

HOW LONG HAVE YOU BEEN ON ODETTE STATION?

EIGHT YEAR.



UH-HUH, EXCEPT WE GENOTYPED. HIGH PERCENTAGE YOU'RE NOT JAN BREMER, YOU LOOK LIKE A MATCH FOR TRIN TACKER.

LOW-GRADE CRIM. RESIDENT OF LUDMILLA HABITAT.

UNTIL THREE MONTHS AGO, STUDYING YOUR PAPER TRAIL NOW TO SEE WHERE IT STARTS GETTING FAKE.

SLIP OVER ON A FREIGHTER, DID YOU?



DIS-RE-SPECT, BUT THE LEPER HEART KNOWS BOTH OF YOU NOW.

IT'LL KEEP ITS PROMISES ABOUT YOU MOST CAREFULLY.

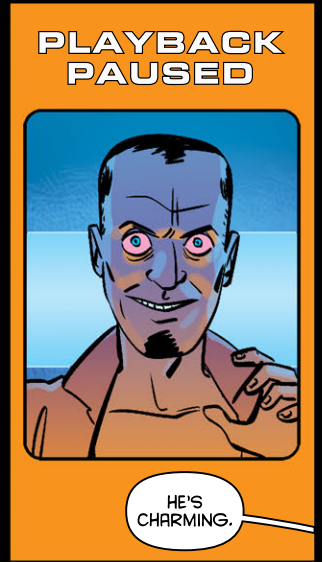

# PLAYBACK PAUSED

HE'S CHARMING.



WE RAN TRACES ON SOME OF HIS EFFECTS. JEWELLERY. CLOTHING.

MANUFACTURE SPECS MATCH LUDMILLA.

I'M LISTENING.

WE THINK BREMER AND HIS ASSOCIATES ARE PART OF A LUDMILLA SECT, IMPORTING THEIR CREED TO ODETE.

WE WANT TO FOLLOW THE LEADS TO LUDMILLA.

FULL SQUAD. FORENSIC.



I CAN'T SPARE THE MANPOWER AND I SURE AS HELL CAN'T FIND ROOM IN THE BUDGET TO TRANSFER THAT KIND OF MASS.

JUST THE TWO OF YOU. I'LL HOOK YOU IN WITH LUDMILLA H.S.D.

OKAY, THEN.



KURTIS? WHAT WAS THE OTHER NAME? THE ONE YOU WOULDN'T SAY?

SORRY. I WON'T REPEAT IT.

IT'S IN THE REPORT.

OH YEAH.

"PHALE CHRONOZON"...



=>MMMGN!<=



JEEZ. JUST SICKED UP IN MY MOUTH A LITTLE BIT.

GUESS WE'LL FIND OUT...

THE HELL IS THIS?

Odette Habitat  
Owned: Sugarsurf Pharma  
Completed: 2076 AD

Population: 209,000  
First occupied 2077, five  
years after the final  
evacuation of Earth

"Interhab Ferry"  
Type: 818 Venta model transit shuttle  
Year of manufacture: 2046 AD  
Route: Odette Habitat to Ludmilla  
Habitat (weekly, direct)  
Trip duration: 87 hours

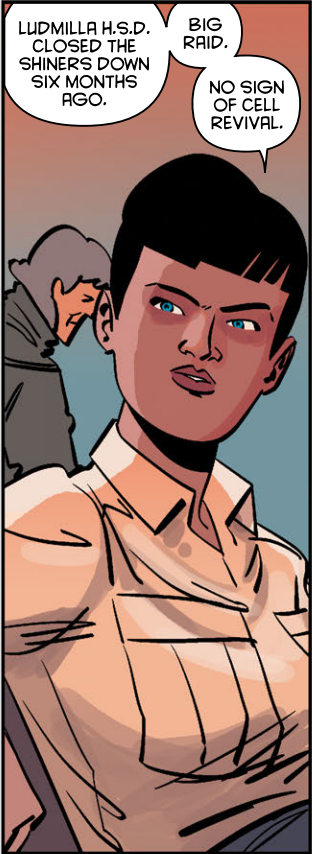



NEVER FIGURED OUT WHY YOU HATE REJOICERS, BRINK.

OUR SPECIES IS CHOKING ON NUDGE JUST TO GET THROUGH THE DAY, AND *THEY'VE* FOUND A POSITIVE SPIN.

"PLANET EARTH DIED, BUT LOOK! WE'RE ALIVE!"

THEY SMELL.



THERE'S THAT.

AND THEY'RE A CULT.

OKAY. BUT NOT THE SORT OF CULT WE'RE TALKING ABOUT.

DON'T THINK THEY GET ON ANYONE'S WATCH LIST UNLESS THEY SLEEP IN DOORWAYS OR WHIZZ IN THE HALLS.

WHATEVER.



SO... BREMER--

TRIN TACKER.

RIGHT, REAL NAME TRIN TACKER...NO OBVIOUS CONNECT WITH EITHER OF THE OTHER CULTS.

THE PRIVATE SANCTUARY SEEMS TO CENTRE AROUND LUDMILLA'S REACTOR LEVELS.

THE EXHALATION IS AN OUTGROWTH OF THE ATMOSPHERIC WORKERS UNION, AN OLD TRADE CLUB TURNED BAD.



TACKER'S NEVER BEEN A MEMBER OF THE A.W.U.

HE SPENT MOST OF HIS LIFE WORKING ELECTRICALS IN A LOOP CALLED HANG STREET, ON THE SUNSIDE.

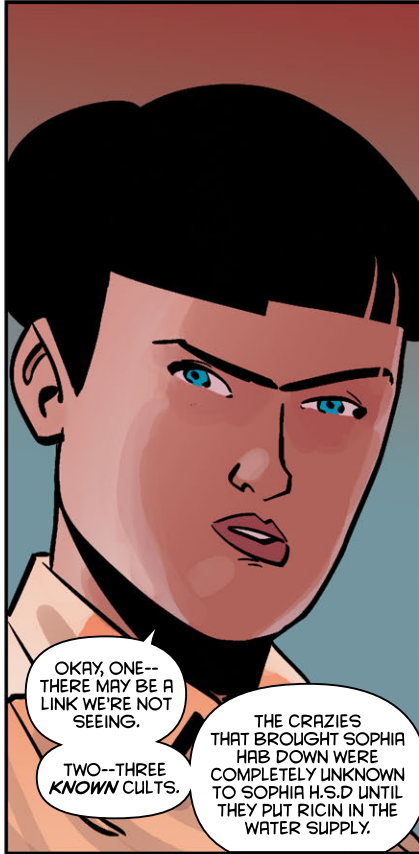

OKAY, ONE-- THERE MAY BE A LINK WE'RE NOT SEEING.

TWO--THREE *KNOWN* CULTS.

THE CRAZIES THAT BROUGHT SOPHIA HAD DOWN WERE COMPLETELY UNKNOWN TO SOPHIA H.S.D UNTIL THEY PUT RICIN IN THE WATER SUPPLY.

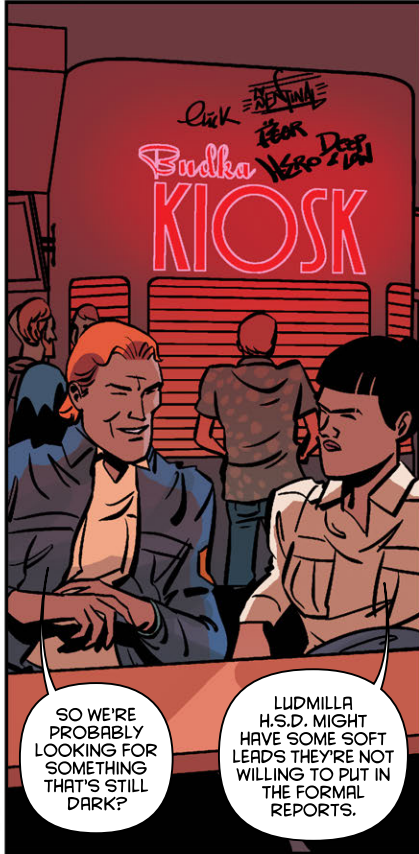

Click ~~NO TALK~~  
Budka ~~FEAR~~ ~~DEEP~~ ~~HERO~~ ~~TRIN~~  
KIOSK

SO WE'RE PROBABLY LOOKING FOR SOMETHING THAT'S STILL DARK?

LUDMILLA H.S.D. MIGHT HAVE SOME SOFT LEADS THEY'RE NOT WILLING TO PUT IN THE FORMAL REPORTS.

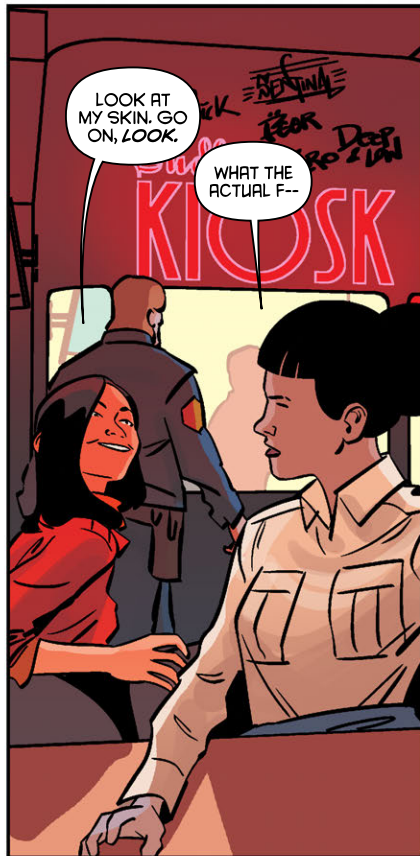
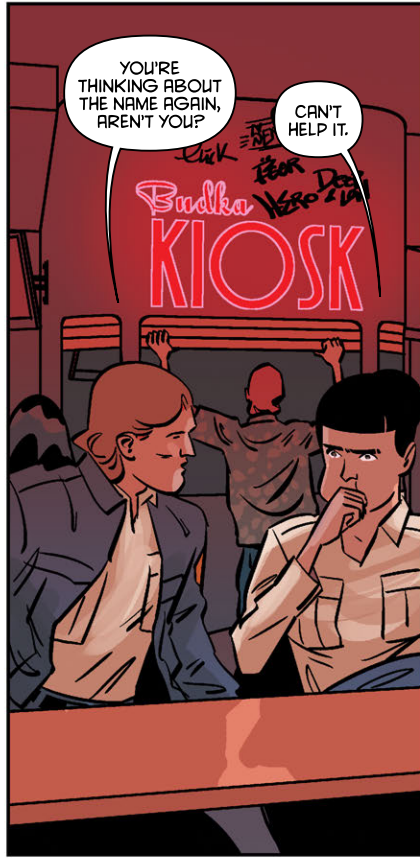



I'M A BEHAVIOURAL BIOLOGIST. I RUN **MACROBIO** ON LUDMILLA.

YOU'RE HABITAT SECURITY DIVISION?

YEAH.



YOUR STOMACH PROBLEMS...NAUSEA, RIGHT? IT'S DIET. I KNOW, I KNOW, I GET A BIT PREACHY.

IT'S ALL THE SYNTH. AND NUDGE DRUGS. I MEAN, A WHOLE COCKTAIL.

I EAT **CLEAN**, YOU SEE. ALL **MACRO** OR **HYDROPONIC**. NOTHING **SYNTH**. **NADA**.

I'VE MANAGED TO EAT OFF THE GRID FOR THREE YEARS NOW. I USED TO HAVE **CHRONIC I.B.S.**



ACTUALLY, YOUR SKIN IS **AMAZING**.

I **KNOW!** I FEEL SO GOOD FOR IT. YOU **REALLY** OUGHT TO TRY IT.

NOT A LOT OF CHOICE NOW WE'RE ON THE BRINK.

SYNTH AND NUDGE, IT'S SO HORRIBLE. **TOXIC**.

UNLESS YOU'RE HIGH END, OF COURSE.



WELL, **NO**. YOU CAN CULTIVATE. THERE ARE SIMPLE KITS TO PURIFY THE MATERIALS.

IF YOU COME BY **MACROBIO**, I'D LOVE TO GIVE YOU SOME **VAC-PACS** TO TRY. **SALAD**. **RADISH**. **QUINOA**.

I HAVE NEVER KNOWINGLY EATEN A **RADISH**.



COME BY. YOU'RE VISITING **LUDMILLA** FOR A WHILE?

**SHORT TOUR**. **OFFICIAL**.

COME BY. I'LL HAVE **RADISHES** READY.

IF I GET A CHANCE. **THANKS**.



**FRANNIE**.

**BRIDGET**. **BRIDGE**.

THIS IS MY PARTNER, **BRINK**.

THAT'S **FUNNY!**

**SHORT FOR BRINKMANN**.

AND YES, IT **IS**. **BRINK** ON THE **BRINK**.



DIDN'T KNOW WHAT YOU WANTED, SO I GOT YOU A SOY-DOG.

THAT STUFF'LL KILL YOU.

IT'LL HAVE TO JOIN A *QUEUE*.

THIS IS FRANNIE. SHE'S... SHE EATS CLEAN. NO SYNTH. SHE WAS TELLING ME ALL ABOUT IT.



THE TRIP MUST BE FLYING BY.

YOUR PSORIASIS AND WATER-RETENTION ISSUES WOULD REALLY IMPROVE IF YOU ATE CLEAN, MR BRINKMANN.



I...

THE HELL? WE'VE ONLY JUST MET AND YOU'RE CRITIQUING MY PERSONAL APPEARANCE?

DOES THIS WORK FOR YOU IN BARS?

HA HA! HE'S REALLY FUNNY, BRIDGE!

HA, HE'S REALLY NOT FUNNY AT ALL.



I'M GOING TO GO CHECK ON MY LUGGAGE. PEOPLE JUST TAKE STUFF OUT OF THE RACKS, YOU KNOW THAT? JUST DUMP IT ON THE FLOOR!

I'VE GOT THIS SPECIAL NEW STRAIN OF CHICKPEA. JUST BEEN OVER TO ODETTE TO COLLECT IT. IT'S *GENE PURE!* CAN'T WAIT TO GET IN THE VATS!

I'LL *SEE* YOU, THEN.

OKAY, THEN.

BEST OF LUCK WITH THE NUTLOAF.



SHE WAS...

GOOFY?

PUNCHABLE.

YOU WANT THIS?

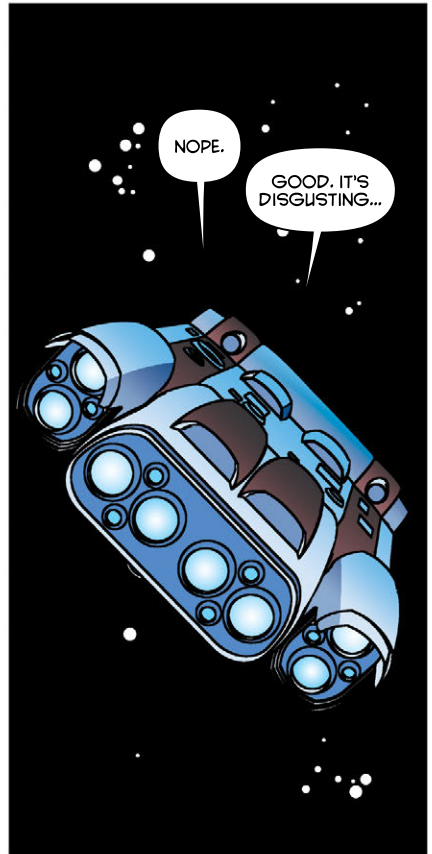

NOPE.

GOOD. IT'S DISGUSTING...

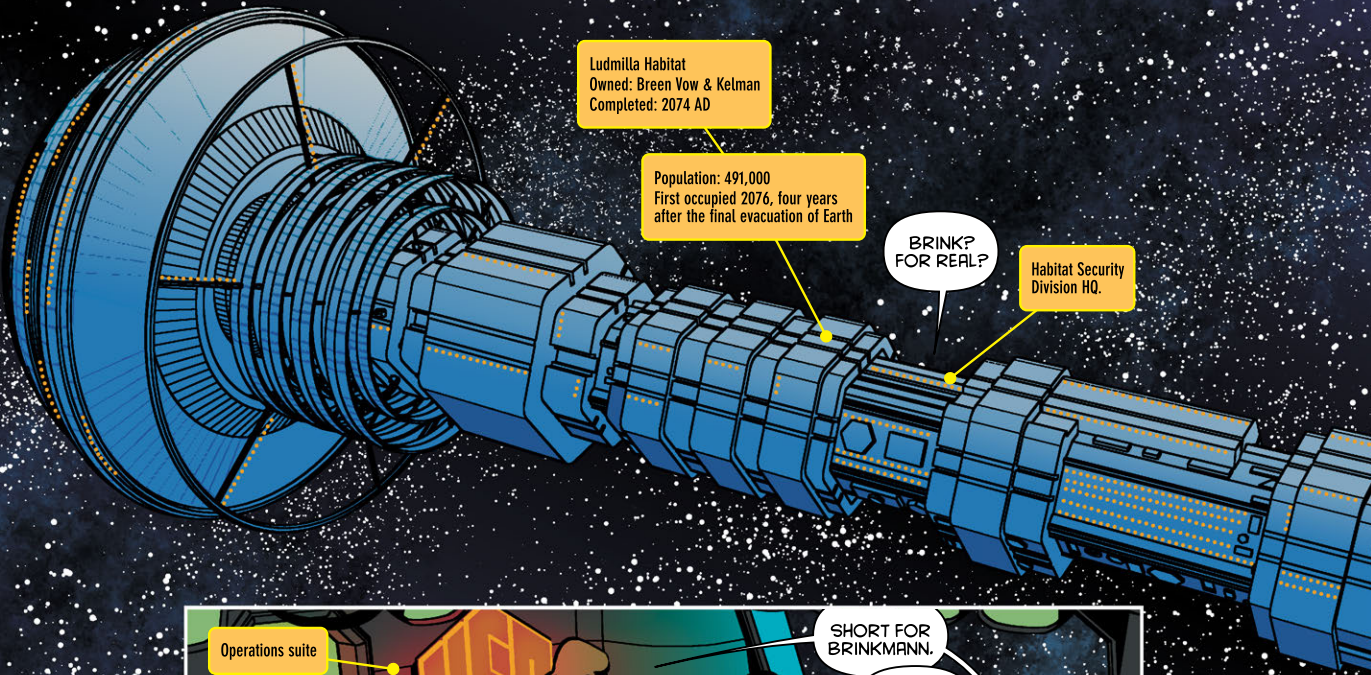

Ludmilla Habitat  
Owned: Breen Vow & Kelman  
Completed: 2074 AD

Population: 491,000  
First occupied 2076, four years  
after the final evacuation of Earth

BRINK?  
FOR REAL?

Habitat Security  
Division HQ.

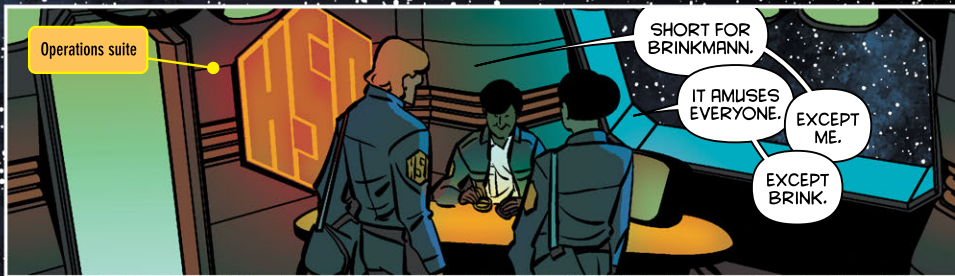

Operations suite

SHORT FOR  
BRINKMANN.

IT AMUSES  
EVERYONE.

EXCEPT  
ME.

EXCEPT  
BRINK.



Heh.

OKAY, THAT'S  
YOUR ACCREDITATION  
SORTED.

SAME SWIPE  
ACCESS AS  
LOCAL HSD.

THANKS.

Tracelet personal  
data device



DON'T MEAN YOU  
DON'T NEED A WARRANT  
IF IT AIN'T REASONABLE  
SUSPICION.

OF  
COURSE.

Hassan, Kurad  
Investigator, Habitat  
Security Division  
Born: Antioch  
Habitat 2070

I'VE ARRANGED  
BERTHS FOR YOU IN  
HSD QUARTERS.  
NOT MUCH TO WRITE  
HOME ABOUT--



--BUT THERE  
AIN'T NO HOME  
TO WRITE TO  
ANYHOW.

YOU HEARD  
THAT ONE  
BEFORE,  
HUH?

I HAVE.

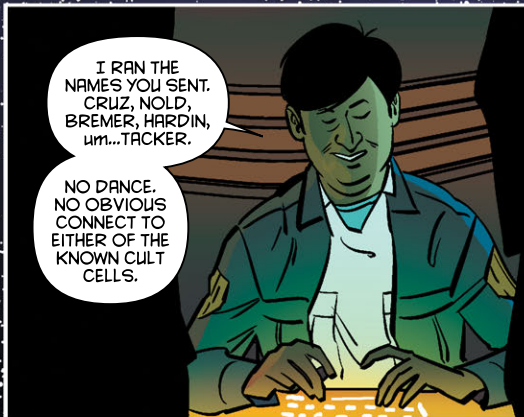

I RAN THE  
NAMES YOU SENT.  
CRUIZ, NOLD,  
BREMER, HARD'N,  
um...TACKER.

NO DANCE.  
NO OBVIOUS  
CONNECT TO  
EITHER OF THE  
KNOWN CULT  
CELLS.



THAT'S  
THE EXHALATION  
AND THE PRIVATE  
SANCTUARY?



PRIVATE  
SANCTUARY  
ORDER OF LOSS,  
RIGHT. THERE WERE  
THE SHINERS TOO,  
BUT WE SHUT  
THEM DOWN.

BEFORE YOU  
ASK, I CHECKED  
THE SHINER FILES  
TOO, AND NOTHING  
FLAGGED THERE  
EITHER.



SOFT LEADS?

JUST BETWEEN US, I MEAN?

WELL, WE KEEP IT LOW, BECAUSE YOU KNOW HOW SHIT SWIRLS UP, BUT WE GOT A GUY WORKING UNDERCOVER IN BOLO LOOP WHO SAYS HE'S GOT SIGNS OF SOMETHING GEARING UP.

NOTHING SOLID.

CAN WE MEET WITH HIM?

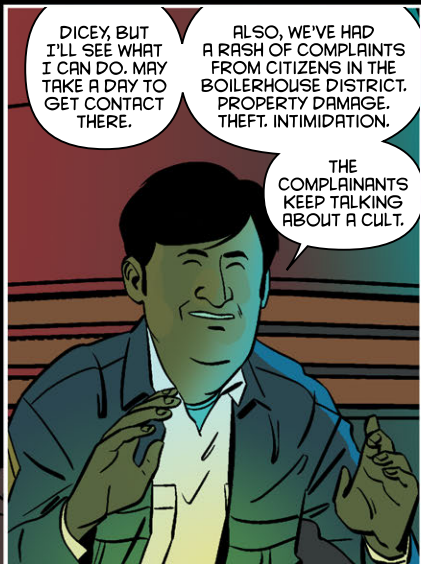

DICEY, BUT I'LL SEE WHAT I CAN DO. MAY TAKE A DAY TO GET CONTACT THERE.

ALSO, WE'VE HAD A RASH OF COMPLAINTS FROM CITIZENS IN THE BOILERHOUSE DISTRICT. PROPERTY DAMAGE. THEFT. INTIMIDATION.

THE COMPLAINANTS KEEP TALKING ABOUT A CULT.



AGAIN, NOTHING SOLID. FOLLOW-UPS FOUND NO TRACE OF CULT ACTIVITY.

CAN WE GET A LIST OF NAMES? THE COMPLAINANTS?

NO PROBLEM.



AND HEY-- WELCOME TO LUDMILLA HABITAT.



Designated accommodation cubicle, Ludmilla HSD quarters.

WELL, THIS IS SWISH.



MINE'S NO BETTER. YOU WANNA SWAPP?

YOU SAID YOURS WAS NO BETTER.

Hrk. MORE MOTORCYCLES, LESS SKIN.

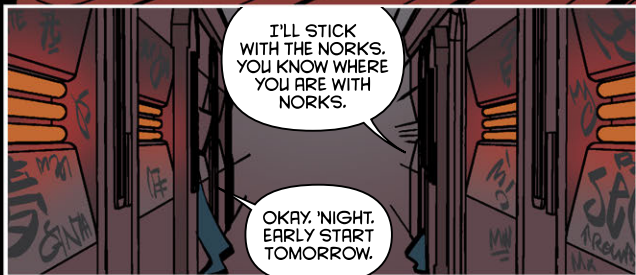

I'LL STICK WITH THE NORKS. YOU KNOW WHERE YOU ARE WITH NORKS.

OKAY 'NIGHT. EARLY START TOMORROW.



GEEZ. THE NIPPLES FOLLOW YOU AROUND THE ROOM.

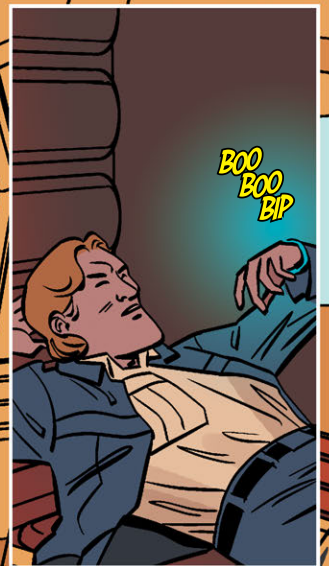
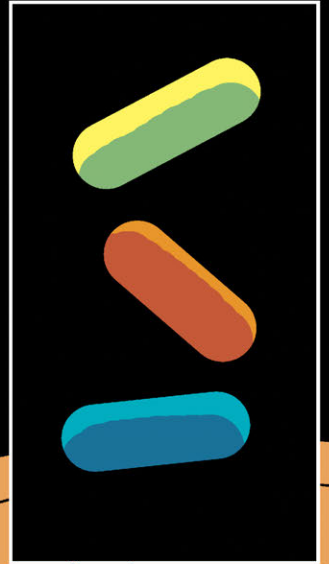
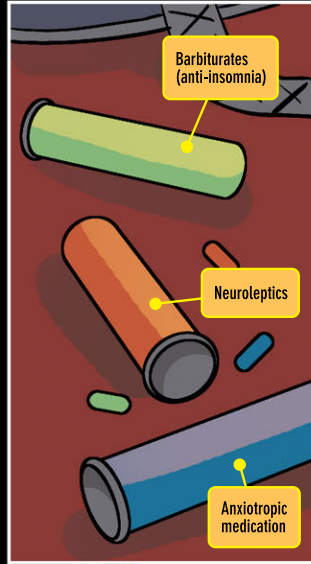



THIS IS THE GUY. HASSAN IN OPS SAID YOU WANTED TO SPEAK TO ME.

OH, RIGHT. YOU GOT A NAME?



BILDER.

THAT'S YOUR NAME?

NO, THAT'S WHAT YOU CALL ME.

232 OVERWALK IN TEN. COME ALONE.



Loop 232 overwalk



BOOBOOBIP

BRINKMANN.

WHERE ARE YOU?

GONE FOR A WALK. WHAT'S UP, BRIDGE?

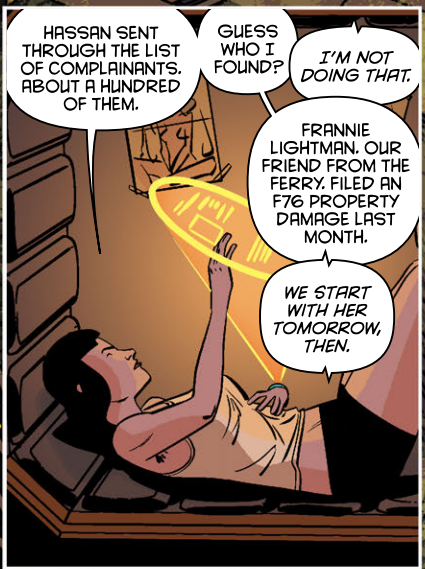

HASSAN SENT THROUGH THE LIST OF COMPLAINANTS. ABOUT A HUNDRED OF THEM.

GUESS WHO I FOUND?

I'M NOT DOING THAT.

FRANNIE LIGHTMAN. OUR FRIEND FROM THE FERRY. FILED AN F76 PROPERTY DAMAGE LAST MONTH.

WE START WITH HER TOMORROW, THEN.



GOTTA GO.



BILDER?

S'GONNA WAKE UP ANY DAY NOW.

Uh, WHAT IS?



VOVEK. ILLUSTRIOUS TRULL. MR MIBBER.

YOU GONNA MAKE SOME SENSE SOON?

NAMES. THEY'RE ALL NAMES. DIFFERENT CULTS, DIFFERENT NAMES. THE EXHALATION CALL IT VOVEK. THE SHINERS CALLED IT MR MIBBER.

CALLED WHAT?



YOUR BASIC GIANT PRIMORDIAL DAEMON SPACE-GOD.

FUNNY, THEY'RE ALL RAT-SHIT INSANE, BUT THEY GOT THAT *ONE* BELIEF IN COMMON.

THE SUN'S AN EGG, AND INSIDE IT THERE'S A GIANT SLEEPING SPACE-GOD, AND ANY TIME NOW IT'S GOING WAKE UP AFTER A BILLION YEARS AND HATCH.

I HAVE NO IDEA WHAT TO SAY TO THAT.



Uh-huh. CULTISTS BE CRAZY.

BUT *CONSISTENT*. MR MIBBER, UP-ARISING FROM THE SUN-SHELL.

MELANCHOLEMA, BORN OUT OF THE UNREACH. VOVEK AWAKENING AT--

WAITAMINUTE.

WHAT DID YOU JUST SAY?



VOVEK AWAKENING--

BEFORE THAT.



MELANCHOLEMA.



THAT WORD MEAN SOMETHING TO YOU, HUH?

IT CAME UP RELATING TO A PROBLEM ON ODETTE.



MELANCHOLEMA IS ONE OF THEIR GODS.

GIANT PRIMORDIAL DAEMON SPACE-GODS?

RIGHT.

IT'S PART OF THE LANGUAGE USED BY SEVERAL SECTS.

AND IT MEANS?



YOUR BASIC BELIEVER IS OUT OF HIS SKULL ON SUPER-ACTIVE NUDGE, PLUS A LOT OF BANNED SUBSTANCES.

IT MEANS WHATEVER THEY FEEL LIKE IT MEANS THAT MORNING.

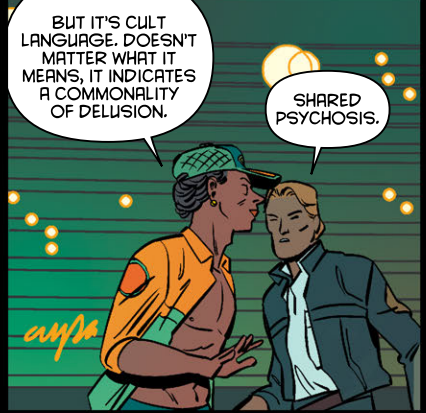

BUT IT'S CULT LANGUAGE. DOESN'T MATTER WHAT IT MEANS, IT INDICATES A COMMONALITY OF DELUSION.

SHARED PSYCHOSIS.



RIGHT. I'VE BEEN TRACKING LANGUAGE INSTANCES.

"MELANCHOLEMA" IS A KEY TAG.

IT'S GETTING WHISPERED A LOT DOWN HERE IN BOLO, AND IN BOILERHOUSE TOO.

A NEW CULT?

PROBABLY. IT DOESN'T HAVE A NAME YET. MY GUESS IS IT'S GROWING, ESTABLISHING ITS DELUSION.

ANOTHER MONTH, MAYBE TWO, IT'LL START ANNOUNCING ITSELF AND WEARING ITS IDENTITY, SAME AS THE OTHER GROUPS.



YOU SOUND DOUBTFUL.



MAYBE I'VE BEEN UNDER TOO LONG. THIS ONE FEELS HINKY.

LIKE IT'S NOT FOLLOWING THE SAME PATTERN. LIKE IT WANTS TO STAY COVERT. *ESOTERIC*. KNOWN ONLY TO THOSE WITHIN.

THAT WOULD BE NEW.

WHY?

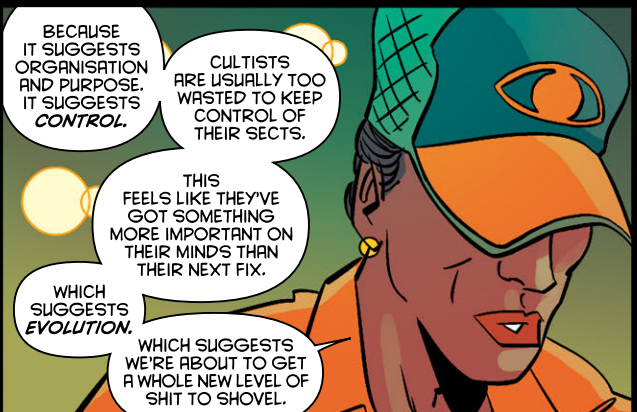

BECAUSE IT SUGGESTS ORGANISATION AND PURPOSE. IT SUGGESTS *CONTROL*.

CULTISTS ARE USUALLY TOO WASTED TO KEEP CONTROL OF THEIR SECTS.

THIS FEELS LIKE THEY'VE GOT SOMETHING MORE IMPORTANT ON THEIR MINDS THAN THEIR NEXT FIX.

WHICH SUGGESTS *EVOLUTION*.

WHICH SUGGESTS WE'RE ABOUT TO GET A WHOLE NEW LEVEL OF SHIT TO SHOVEL.

Ludmilla Habitat

Boilerhouse district

THIS BILDER GUY, HE'S GOING TO KEEP US ADVISED?



IF HE HEARS ANYTHING.

YOU COULD'VE TAKEN ME ALONG TO THE MEET.

YOU WERE RESTING.



YOU SHOULD HAVE RESTED TOO. YOU LOOK LIKE A CRAP SANDWICH, BRINK.



IT'S YOU!

I KNEW YOU'D COME AND VISIT; I KNEW IT!

I PUT ASIDE SOME MACRO VEG FOR YOU!



ACTUALLY, THIS IS BUSINESS, FRANNIE.

OOOH! EXCITING!

YOU FILED A F76 PROPERTY DAMAGE LAST MONTH. SAYS YOU SUSPECTED SECT ACTIVITY?



THAT'S RIGHT.

BOB! COME OVER AND MEET THESE GUYS!



HI, BOB ADLER.

BOB'S ONE OF MY *REGULAR* CUSTOMERS. BOB'S A *GURU*; SELF-HELP STUFF. BOB'S INTO *CLEAN LIVING*.

BOB FILED A REPORT TOO.

"BOB" IS STARTING EVERY SENTENCE.



YOU'RE *SO* FUNNY!

MY PLACE IS DOWN THE LOOP.

I GOT MY WINDOWS SMASHED SAME NIGHT AS FRANNIE'S.

SLOGANS TOO.

YOU'RE A WHAT, A "*GURU*"?



NO, A LIFE-COACH. THIS LIFE WE'VE BEEN GIVEN IS PRETTY BAD, RIGHT? I JUST HELP PEOPLE.

HE'S A *WIZARD*!



IT'S JUST SIMPLE STUFF. CLEAN LIVING... NO SYNTH FOOD, NO DRUGS, NO NUDGE.

AND, LONG-TERM, I BELIEVE IN *MIGRATION*.



TO... WHERE?



MANKIND KILLED THE EARTH. WE CAN'T LIVE ON THE BRINK FOREVER. IT'S JUST NOT SUSTAINABLE.

I SUPPORT THE MOVEMENT TO DEVELOP A VIABLE PROPULSION SYSTEM SO THAT WE CAN MOVE, AS A SPECIES, TO A NEW SOLAR SYSTEM AND MAKE A FRESH BEGINNING.

THAT IDEA'S BEEN SHOT DOWN A THOUSAND TIMES. THE SHEER LOGISTICS ARE UNFEASIBLE.



THEY ARE AT THE MOMENT. BUT THEN SO'S LIVING HERE FOR MORE THAN A FEW MORE DECADES.

THE CONCEPT NEEDS SERIOUS CONSIDERATION. SADLY, THE CORPORATIONS TEND TO NIX THINGS.

WITH MANKIND EFFECTIVELY TRAPPED IN A HABITAT NETWORK, THE BIG CS HAVE GOT THE MOST MONOPOLISED, CAPTIVE, DESPERATE CONSUMER BASE EVER.



THEY'VE PUT US IN CAGES AND MADE US UTTERLY DEPENDANT ON THEIR GOODS. MIGRATION WOULD BE CONSIDERABLY DISADVANTAGEOUS TO THEIR PROFIT MARGINS AND--

COULD WE STICK TO THE SUBJECT?

PROPERTY DAMAGE? VANDALISM?

THERE'S A LOT OF THAT. THE SECTS.



HOW DO YOU KNOW IT'S SECTS?

THEY SHOUT THROUGH THE DOOR AT NIGHT. THEY LEAVE PAMPHLETS. THEY WRITE SLOGANS--

YOU KEEP ANY OF THESE PAMPHLETS?



Ugh, NO. I RECYCLE THEM FOR COMPOST.



YOU MENTIONED SLOGANS.

YEAH, THEY DAUB THIS VILE STUFF UP THEN IT TAKES SANITATION FOUR MONTHS TO COME AND HOSE-BURN IT OFF.



THERE'S A LOT OF TAGGING.

NOT LIKE THIS.

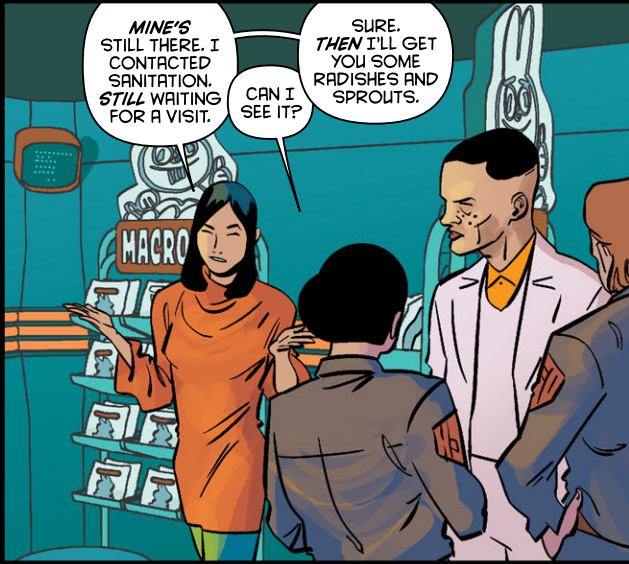

MINE'S STILL THERE. I CONTACTED SANITATION. STILL WAITING FOR A VISIT.

CAN I SEE IT?

SURE. THEN I'LL GET YOU SOME RADISHES AND SPROUTS.

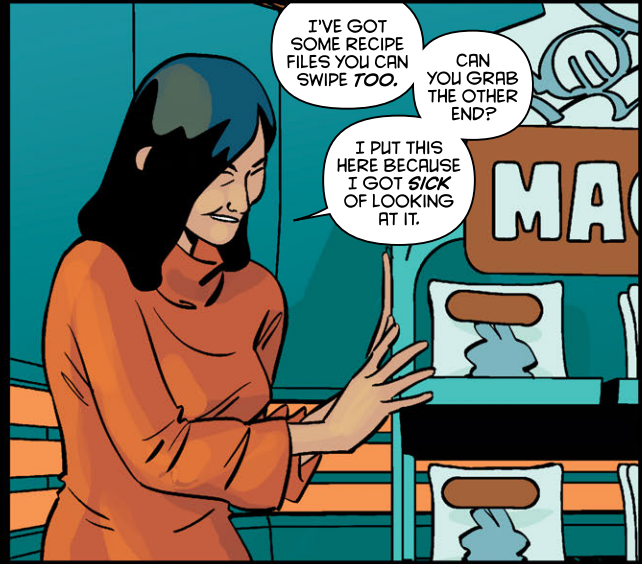

I'VE GOT SOME RECIPE FILES YOU CAN SWIPE TOO.

CAN YOU GRAB THE OTHER END?

I PUT THIS HERE BECAUSE I GOT SICK OF LOOKING AT IT.



LIFT FROM THE KNEES, BRIDGET.

YEAH, YEAH...



BRINK? LOOK AT THIS.

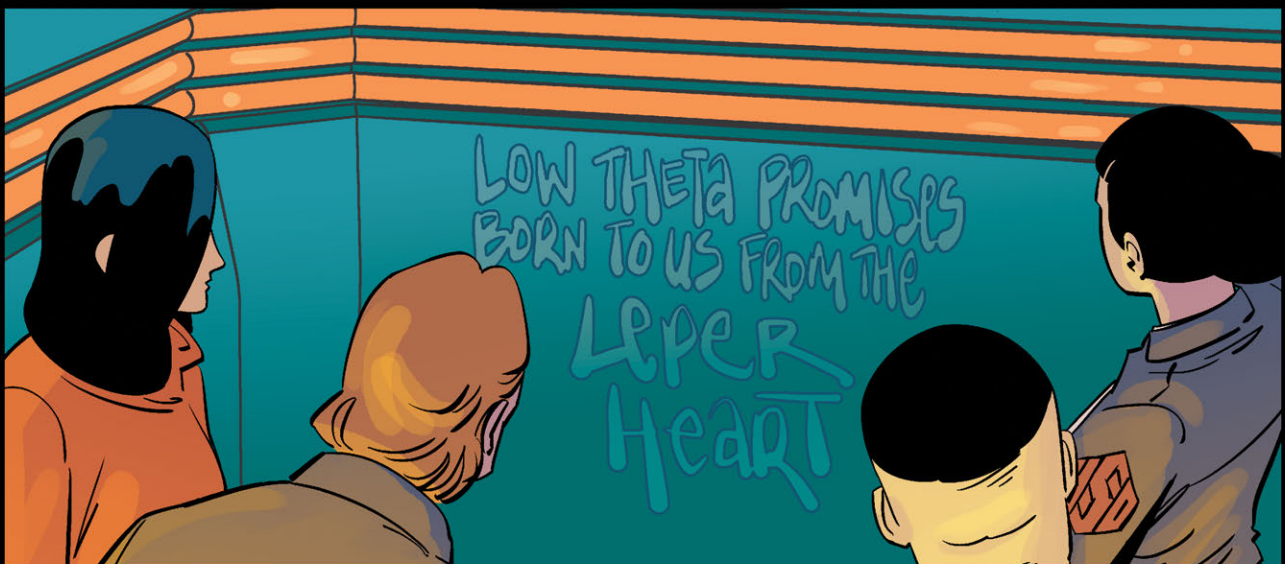

LOW THETA PROMISES  
BORN TO US FROM THE  
LEPER  
HEART

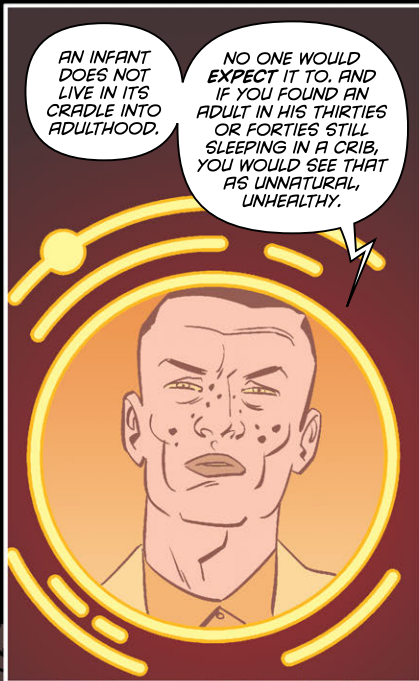

AN INFANT DOES NOT LIVE IN ITS CRADLE INTO ADULTHOOD.

NO ONE WOULD EXPECT IT TO. AND IF YOU FOUND AN ADULT IN HIS THIRTIES OR FORTIES STILL SLEEPING IN A CRIB, YOU WOULD SEE THAT AS UNNATURAL, UNHEALTHY.



WE HAVE OUTGROWN OUR CRADLE. WE'RE NOT INFANTS ANY MORE.

MIGRATION IS OUR NATURAL NEXT STEP.

SCIENCE HAS SO FAR IDENTIFIED SIXTEEN HUNDRED EXTRASOLAR PLANETS THAT MEET THE GAINES SCALE CRITERIA FOR HABITATION.



NOW THE CORPS ARE GOING TO TELL YOU--LOOK AT THE LITERATURE--THEY'RE GOING TO TELL YOU THAT INVESTMENT IN EXOPLANET MIGRATION IS UNFEASIBLE.

THAT THE PRACTICAL REQUIREMENTS ARE ENTIRELY BEYOND THE SCOPE OF BRINK SOCIETY.

THE TWO KEY ISSUES--AND THERE ARE LOTS OF ISSUES--BUT THE TWO KEY ISSUES ARE JOURNEY TIME AND FUEL LOADS.



LET'S TALK A BIT ABOUT THOSE.

WHAT WE NEED IS INVESTMENT IN RADICAL NEW PROPULSION SYSTEMS THAT--

BUSY?

I WAS SPEED WATCHING SOME OF BOB ADLER'S GURU-TUBE SEMINARS.



WHY?

WE'VE BEEN HERE THREE DAYS. LOOKING AT HOOTERS FOR AMUSEMENT PALLS AFTER A WHILE.



WELL, I'VE BEEN DOING SOMETHING USEFUL.

NICE. THAT'S A SOUR MOOD YOU'RE IN TODAY.

EXCEPT IT'S THE SAME SOUR MOOD AS EVERY DAY.

DO YOU WANT TO HEAR OR NOT?

SHOOT.



HASSAN RUSH-JOBBED THE PAINT SCRAPINGS WE TOOK FROM THE MACRO WOMAN'S WALL.

ONLY TOOK TWENTY-EIGHT HOURS. GOOD JOB, HSD FORENSICS.

IT'S NOT PAINT.

IT'S POLYPLASTIC UNDERSEAL FOR USE ON THERMAL DUCTING.

THE DUCT AND VENT MAINTENANCE UNION IS BASED IN BOILERHOUSE.

Ludmilla Habitat

Boilerhouse district

RADISH?



PISS OFF.

YOU'RE REALLY FALLING FOR THAT CRAP?

WELL, MY GUT DOESN'T KNOW WHAT HIT IT, BUT I ACTUALLY FEEL BETTER.

AFTER A DAY.

IT TASTES OF SOMETHING.



OF CRAP.

NO, IT TASTES OF...IT *DOESN'T* TASTE OF SALT AND FLAVOURINGS.

I FEEL BETTER, ALL RIGHT? I STOPPED DROPPING NUDGE TOO.



GOD'S *SAKE*, KURTIS. YOU'RE OFF NUDGE?

BACK OFF, BRINK. WHAT DOSE ARE *YOU* ON NOW?

I NEED *YOU TOGETHER* FOR THIS. SHARP AND FOCUSED, NOT--

FOOD AND PHARMS. THE CORPS' WAY OF KEEPING US ALL IN LINE. SMOOTHING OVER THE SHEER HORROR OF THE *SHIT LIVES* WE LEAD.



YOU SHOULD MAKE A GURU-TUBE SEMINAR.

BRINK, I'M WORRIED ABOUT YOU. THE EDGE YOU LIVE ON--

I'M WORRIED ABOUT *YOU*.



NO NEED.

Affiliated Ducting and Ventilation Maintenance Union (Ludmilla Habitat)

WE CAN'T WALK IN AND RUN AN UN-AUTH INSPECT.

LET ME TAG HASSAN FOR A WARRANT.

WE WON'T GET IT. THE UNIONS HAVE CLOUT.

WE'VE GOT TEN GOOD MINUTES TO PURSUE REASONABLE SUSPICION BEFORE WE GET BOOTED.



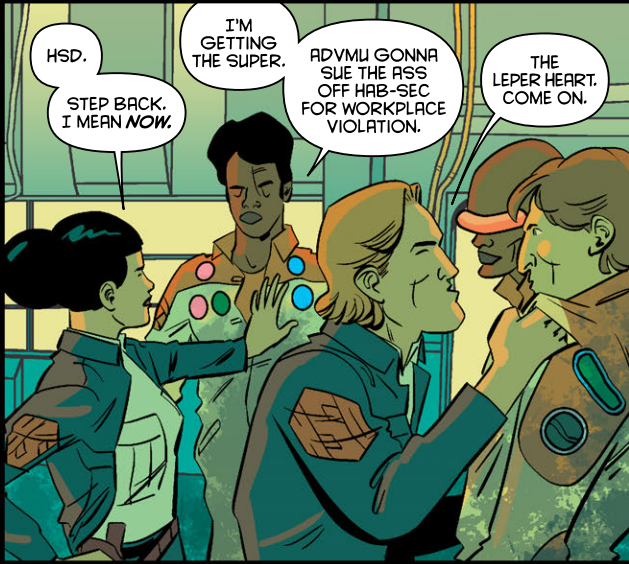

HSD.

STEP BACK. I MEAN NOW.

I'M GETTING THE SUPER.

ADVMU GONNA SUE THE ASS OFF HAB-SEC FOR WORKPLACE VIOLATION.

THE LEPER HEART. COME ON.

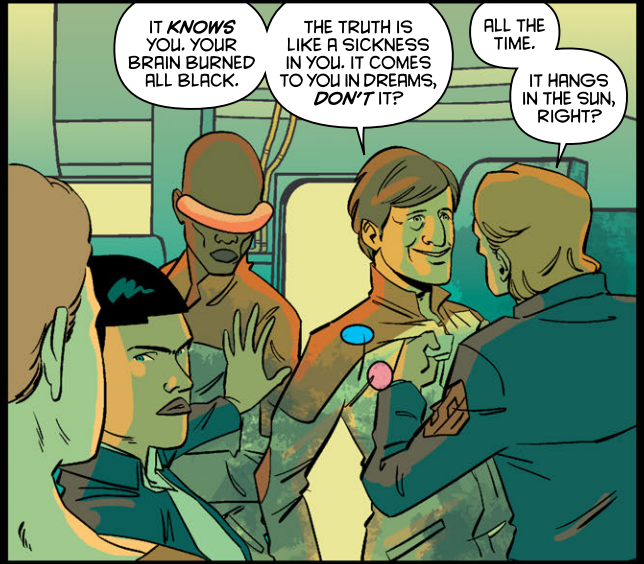

IT KNOWS YOU. YOUR BRAIN BURNED ALL BLACK.

THE TRUTH IS LIKE A SICKNESS IN YOU. IT COMES TO YOU IN DREAMS, DON'T IT?

ALL THE TIME.

IT HANGS IN THE SUN, RIGHT?



YES, SIR, IT DOES! IN THE LEPER HEART OF THE SUN, AND IT'S GOING TO KEEP ITS PROMISES.

SMELL HIS BREATH. HE'S HUFFING POLYMER THINNER.

BRINK...



WHAT DO YOU MEAN YOU'VE DREAMED ABOUT IT?

OH, PLAY ALONG BRIDGE. WE'VE HEARD THEM SPOUT THIS CRAP.

IT'S EASY TO FAKE.

FAKE? YOU'RE FAKING?

NO. MELANCHOLEMA TELLS ME WHAT TO SAY TO KEEP HER OFF MY BACK.

HUH?



SHE DONT UNDERSTAND LIKE WE DO. LET ME IN. I WANNA MEET WITH THE ELDERS.

YOU AIN'T INDUCTED. THEY WON'T SPEAK TO YOU.

I WANNA BE INDUCTED.

YOU DONT KNOW THE TRUTH. NOT ENOUGH. NOT YET. YOU'RE NOT READY.



I KNOW IT. I KNOW PHALE CHRONOZON.

MMMLP!  
JESUS, BRINK.



TELL ME--  
MGG...



BLUUUGHHHH!



GET HIM!  
STOP HIM!

YOU'RE  
OUT OF  
YOUR MIND,  
BRINK!

THIS IS SO FAR  
OFF PROCESS  
WE'LL GET  
HAMMERED  
FOR IGNORING  
PROTOCOL!

NOTHING  
WE GET WILL BE  
ADMISSABLE--



SCREW  
ADMISSABLE.

BRINK, YOU  
CAN'T TALK TO  
A SUBJECT LIKE  
THAT AND EXPECT  
TO BE ABLE TO  
FILE--

SCREW IT!



HALT!  
LAST  
WARNING!



NOWHERE  
TO HIDE!  
COME OUT  
WITH--

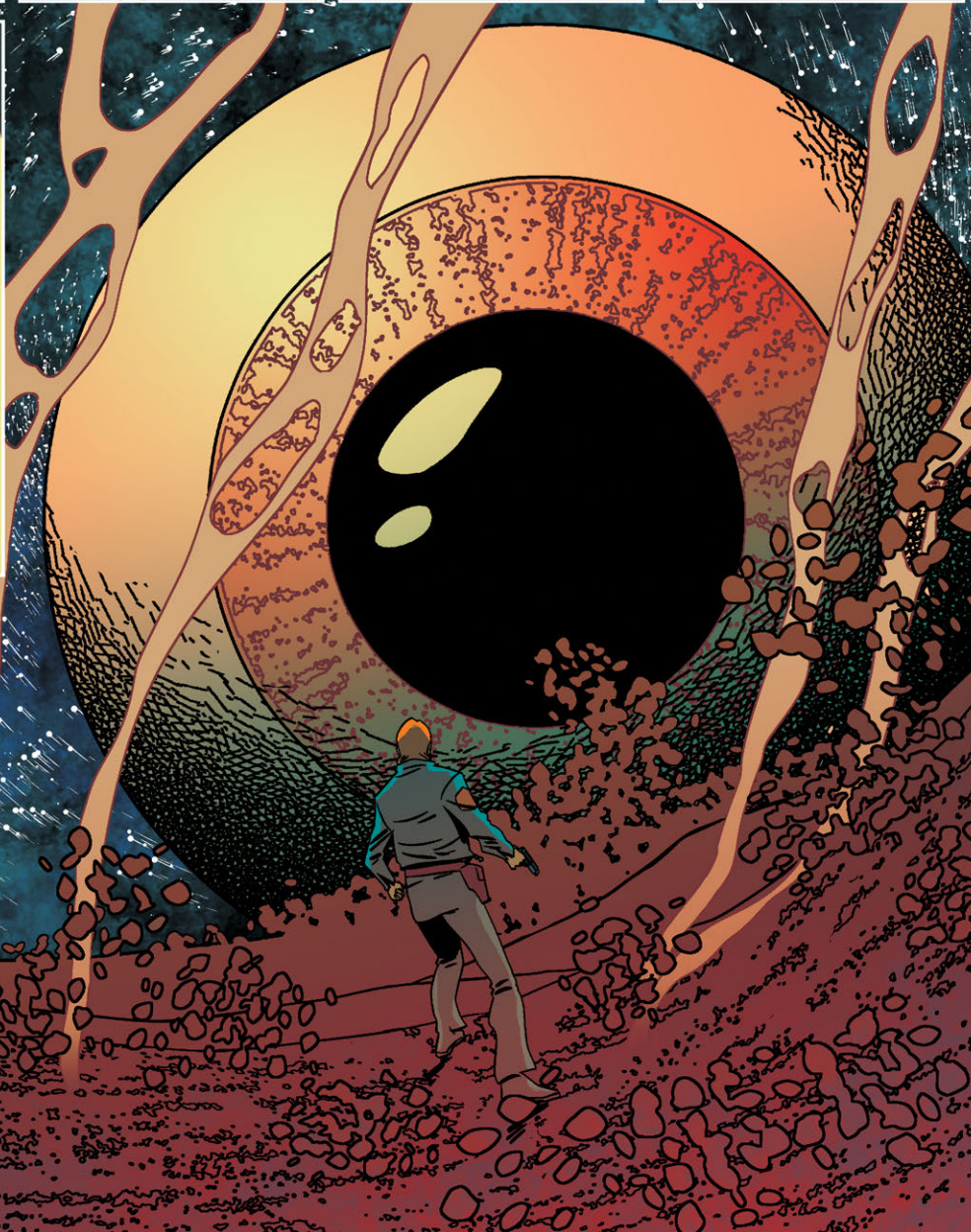



OH GOD...  
OH MY GOD...

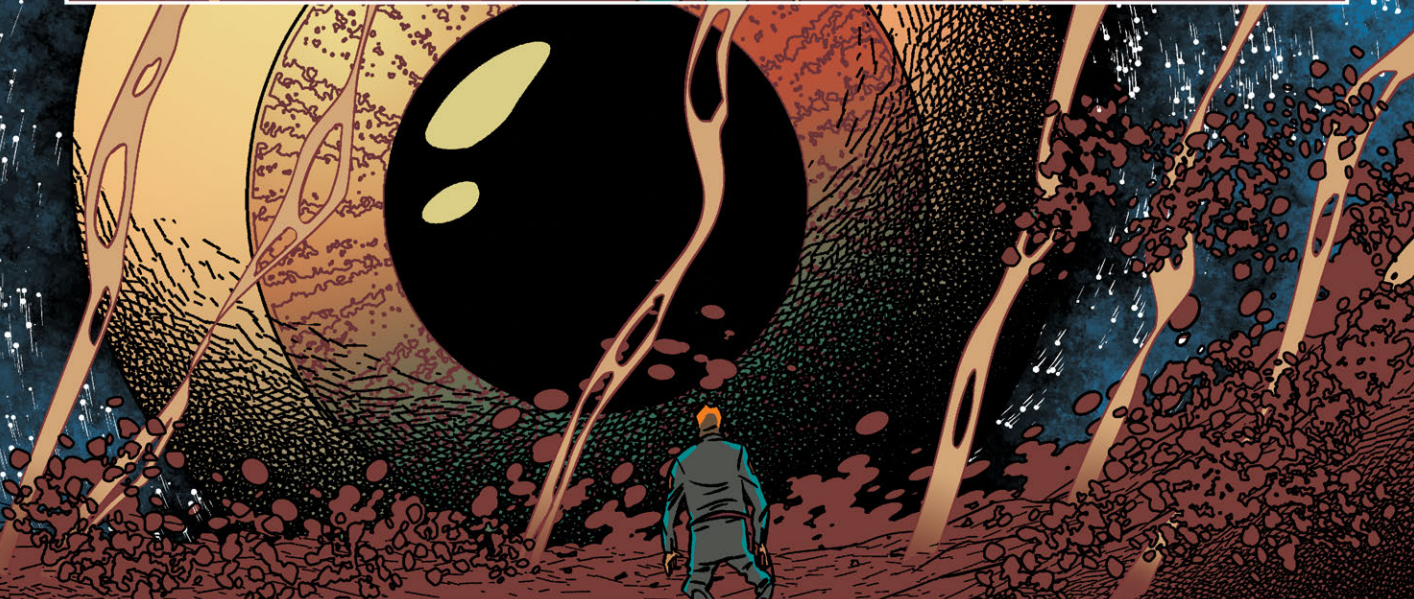

MNNNN...  
NO...

BRINK?  
**BRINK!**  
WHERE DID  
HE GO?

BRINK,  
WHAT DID  
HE **DO** TO  
YOU?



W-WHERE  
WERE YOU?

RIGHT  
BEHIND YOU.  
WHERE DID  
HE GO?

IT'S BEEN  
HOURS... I'VE  
BEEN IN HERE  
FOR **HOURS**...



I WAS RIGHT  
BEHIND YOU.  
YOU'VE BEEN  
IN HERE LIKE A  
SECOND.

BRINK!  
WHERE DID  
HE **GO?**

NO, IT  
WAS **HOURS**,  
BRIDGE...

**BRINK!**  
SNAP OUT  
OF IT!

ARE YOU HIGH?  
DID HE SNAG A  
NEEDLE IN YOU OR  
SOMETHING?



NO.

DAMMIT/ IS THERE ANOTHER EXIT? DID YOU SEE HIM MAKE AN EXIT?



I DON'T KNOW WHAT I SAW.

I SAW--



JESUS, BRINK, CALL FOR BACK-UP.

HIS CO-WORKERS ARE FREAKING OUT! WE CAN'T MARCH ON TO UNION TURF LIKE THIS.

BRINK, WE NEED TO EXTRACT NOW OR CALL IN BACK-UP, OR THERE'LL BE A RIOT.

DO YOU HAVE CAUSE, OR DO WE BACK OFF?

BRINK! DO YOU HAVE CAUSE?



I SEE HIM!

OUT! NOW! COME OUT RIGHT NOW!

YOU CRAZY, BITCH? IT'LL SEE ME!



WHAT WILL?

THE HEART! THE HEART! IT'LL SEE ME FROM THE UNREACH!

MELANCHOLEMA KNOWS ME! IT'S IN MY VEINS!

I'M SICK OF THIS CRAP, GET OUT NOW!



GET HIS ARMS!

YOU'RE DETAINED UNDER THE PERSON OF INTEREST STANDING ORDER.

WHAT'S YOUR NAME?

JESUS!

IT ATE MY NAME.

BRINK, DID YOU CALL BACK-UP?



WHAT?  
NO...

GOD'S  
SAKE,  
BRINK!  
  
YOU LOT!  
*DISPERSE!* LET  
US THROUGH!



LEAVE HIM  
ALONE!

YOU GOT NO  
RIGHTS HERE!  
THIS IS CODE  
VIOLATION!

SECURITY  
PIGS!



THIS IS  
A *SECURITY  
MATTER!* WE  
HAVE REASON  
TO DETAIN!

WE'RE TAKING  
THIS MAN BACK  
FOR INTERVIEW!

GET THE HELL  
OUT OF OUR WAY OR  
I'LL GET RIOT IN HERE  
TO BOOK THE LOT OF  
YOU AND SHUT THIS  
SHOP DOWN FOR  
INSPECTION!

BITCH!



ASSHOLES!

HSD  
SUCKS!

UNION'S  
GONNA  
SUE YOUR  
ASSES!

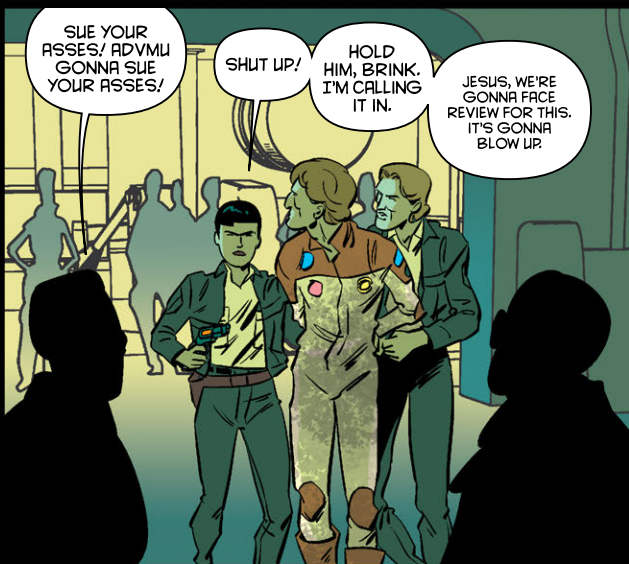

SUE YOUR  
ASSES! ADVMU  
GONNA SUE  
YOUR ASSES!

SHUT UP!

HOLD  
HIM, BRINK.  
I'M CALLING  
IT IN.

JESUS, WE'RE  
GONNA FACE  
REVIEW FOR THIS.  
IT'S GONNA  
BLOW UP.



HSD URGENT ASSIST NEEDED.  
OUTSIDE ADVMU SHOP, BOILERHOUSE.  
REQUESTING RAPID PICK-UP AND  
CODE TWELVE RESPONSE.

COPY THAT.  
STAND BY.



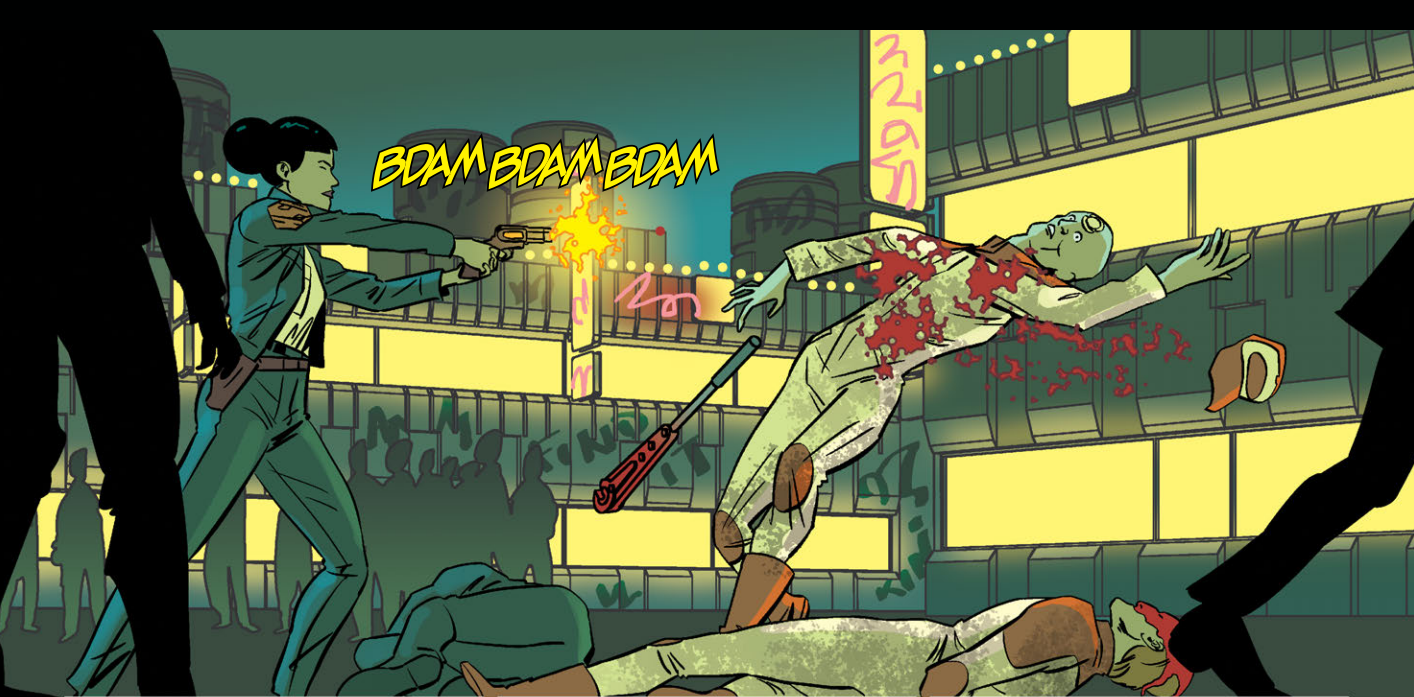

BDAM BDRAM BDRAM



Ludmilla Habitat  
Owned: Breen, Vow & Kelman  
Completed: 2074 AD

Population: 491,000  
First occupied 2076,  
four years after the final  
evacuation of Earth

SO, YEAH,  
THEY--

KURTIS?

Habitat Security  
Division HQ.

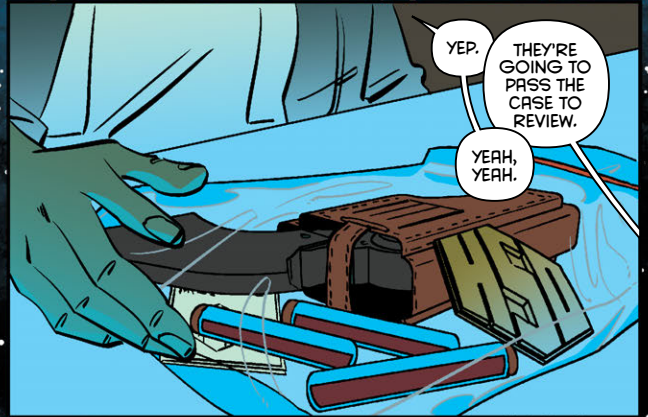

YEP.

THEY'RE  
GOING TO  
PASS THE  
CASE TO  
REVIEW.

YEAH,  
YEAH.

NOT  
JUST THE  
SHOOTING.

WITH A LINE  
DEATH, THE  
WHOLE CASE  
GETS PASSED  
ACROSS.

I GET  
IT.

HSD evidence  
collection pouch

Service side arm,  
warrant card,  
badge, gene-swabs;  
Bridget Kurtis,  
Investigator HSD

YOU'LL HAVE  
TO STAY HERE  
UNTIL REVIEW  
IS FINISHED.

I WANT TO  
STAY ANYWAY,  
TO SEE THE  
CASE OUT.

WELL...

I'M SAYING  
YOU WON'T BE  
ABLE TO DO THAT  
BECAUSE THE  
CASE IS GETTING  
PASSED.

YOU  
UNDERSTAND  
YOU'RE  
**SUSPENDED**,  
RIGHT?

OKAY, BUT THEY'LL  
NEED ME TO RUN  
THROUGH THE  
MATERIALS WITH  
THEM AT LEAST.

I GUESS.

REVIEW NEEDS  
YOU TO BAG  
UP EVERYTHING  
YOU HAVE THAT'S  
CASE-RELATED  
AND SIGN IT  
OVER TO ME.

WE'VE ALREADY  
GATHERED  
BRINKMANN'S  
EFFECTS.

I--

HASSAN, I  
DON'T KNOW  
IF WE HAD  
CAUSE.

I DON'T KNOW  
WHAT BRINK WAS  
THINKING, BUT IT  
SEEMED TO ME  
LIKE IT WAS OFF. I  
DON'T THINK IT'LL  
STAND UP AND--

NO,  
NO, NO.

NOT  
LISTENING.

YOU NEED TO GET IT  
CLEAR BEFORE YOU SAY  
ANYTHING TO ANYBODY,  
INCLUDING ME, OR  
**ANYBODY** FROM  
REVIEW.

YOU NEED  
TO TALK TO  
LEGAL. I CAN  
GIVE YOU A  
CONTACT.

YOU NEED TO  
HAVE THE  
CONVERSATION  
SOON.

KURTIS, DO YOU  
UNDERSTAND WHAT  
I'M SAYING?

YEP.



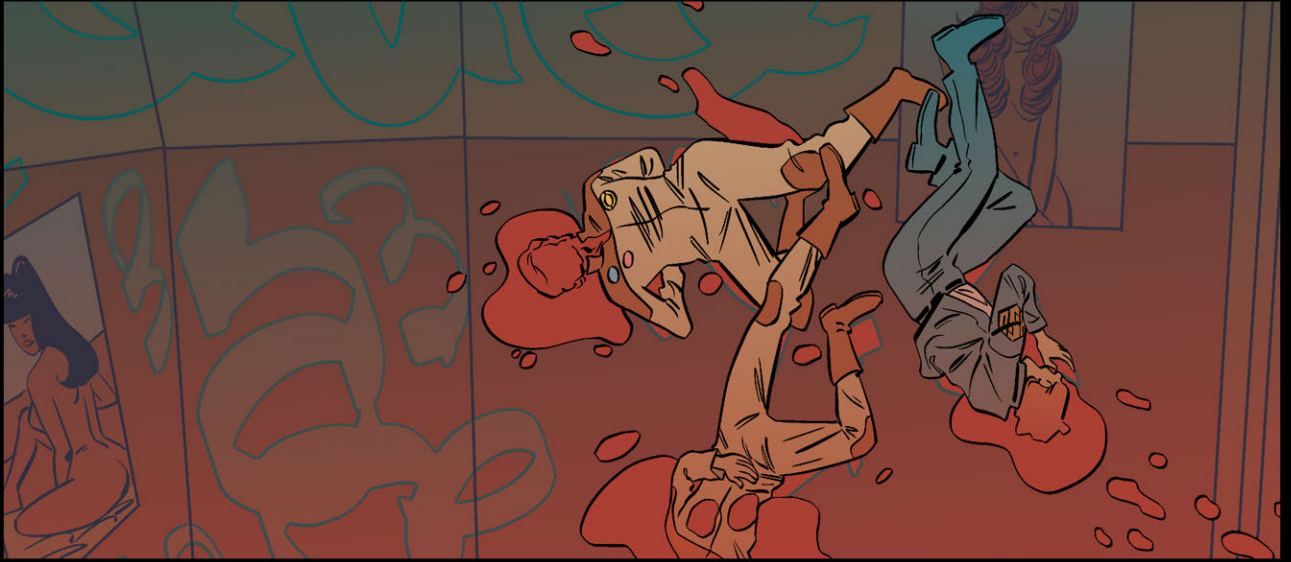



Loop 445 Bolo



Escalade District 32



Boilerhouse District

Affiliated Ducting and Ventilation Maintenance Union (Ludmilla Habitat)



YOU KURTIS?



I'M BILDER.



I GOT STOOD DOWN LAST NIGHT. THAT'S NINE MONTHS' UNDERCOVER BUILD-WORK DOWN THE PAN.

REVIEW KNOWS I SPOKE TO BRINKMANN.

HOW?



HASSAN REPORTED THE CONTACT. YOU'LL HAVE MENTIONED IT IN YOUR STATEMENT.

I HAVEN'T MADE A STATEMENT YET. I GOT AN APPOINTMENT WITH REVIEW IN THREE DAYS. I NEED TO TALK TO LEGAL FIRST.

YEAH, YOU NEED TO DO THAT.



WHEN YOU WENT IN THERE, DID YOU HAVE CAUSE?

IT WAS BRINK'S CALL.

DID HE HAVE CAUSE?



YOU KNOW THE ADVMU IS SUING HAB-SEC?

NO. FOR WHAT?

NOT CLEAR YET. CODE VIOLATION AT LEAST. HARRASSMENT. TRESPASS. UN-AUTH.

SCREW THEM.



YOU REALISE THE CIRCUMFERENCE OF THE SHIT HERE, KURTIS? THE UNIONS HAVE HUGE PULL. WE'VE GOT AN OFFICER KILLED IN THE LINE, A POSSIBLE SUSPECT KILLED WHILE UNDER ARREST. A POSSIBLE UNJUSTIFIED SHOOTING. THAT'S TWO DEAD ADVMU WORKERS.



THE PERP WAS KILLING BRINK AND THE SUSPECT. IT WAS JUSTIFIED.

YEAH, BUT IF HE WAS PROVOKED BY AN UN-AUTH INSPECT AND YOU CAN'T SHOW CAUSE--

DID YOU FIND ME JUST TO PISS ME OFF?



NO. I FOUND YOU TO TELL YOU THAT YOU POKED SOMETHING AND WOKE IT UP.

THERE ARE RIOTS BREWING ALL THROUGH BOILERHOUSE. SOME OF THAT IS THE USUAL ANTI-HSD CRAP, BUT THE REST IS LIKE PRESSURE VENTING.

LIKE THE COMMUNITY HERE IS PROTECTING ITSELF.

FROM WHAT?



FROM THE LIGHT THAT SHINES IN WHEN THE ROCK GETS TURNED OVER. I'VE BEEN WORKING SECT-CRIME FOR SIX YEARS. EVERY SINGLE CASE, THE SECT HAS BEEN SMALL. THIRTY MEMBERS MAX.

THEY GET SHUT DOWN BY US OR THEY COLLAPSE UNDER THEIR OWN INSANITY. I THINK THEY'RE ALL JUST SYMPTOMS. OUTGROWTHS AND BY-BLOWS OF SOMETHING BIG THAT'S BEEN THERE ALL ALONG.



THIS ISN'T A NEW SECT, KURTIS. THIS IS THE GRANDDADDY. THIS IS THE SOURCE.

AND IT'S THOUSANDS STRONG.

AND IT'S RIGHT HERE.

BILDER--



WHAT?

I NEED A GUN.





I'M GLAD ABOUT THAT, ACTUALLY. YOU'D BE A PAIN IN THE ASS IF YOU WERE HERE. YOU'D BE NAGGING ME.

YOU'D BE TELLING ME I SHOULD STOP DODGING THE APPOINTMENTS WITH REVIEW AND LEGAL.



YOU'D BE TELLING ME I HAD TO GET MY STATEMENT STRAIGHT WITH A DIVISION REP. ESTABLISH A GOOD CASE FOR CAUSE SO I COULD CLEAR MY NAME.

YOU'D PROBABLY BE TELLING ME TO BLAME IT ON YOU. YOU HAD A SERIOUS NUDGE PROBLEM. ANXIETY ISSUES.



YOU'D BE TELLING ME TO LET MY DEAD PARTNER TAKE THE FALL FOR A BOTCHED INSPECT.

YOU'D BE TELLING ME TO GET THE WHOLE THING CLEARED AWAY SO I COULD GO HOME TO ODETTE.



BECAUSE OTHERWISE I'M GOING TO BE SITTING HERE FOR MONTHS IN THIS BOX OF TITS WHILE LUDMILLA REVIEW RUNS ITS INVESTIGATION.

YOU'D BE TELLING ME TO AVOID BILDER BECAUSE HE'S CRAZY AS A SHIT-TANK RAT.



YOU'D BE YELLING AT ME ABOUT THE GUN I HAD HIM PROCURE FOR ME.



MOST OF ALL, IF I COULD SEE YOU, YOU'D BE TELLING ME THE FACT THAT I COULD SEE YOU WAS **PROOF**.

PROOF OF THE GODDAMN SPACE-GOD DEMONS.

PROOF OF THE MADNESS.



BECAUSE YOU KNOW I'VE BEEN EATING CLEAN AND OFF NUDGE FOR THREE WEEKS.

THERE ARE NO PHARMS SWIMMING IN MY SYSTEM, MESSING WITH MY HEAD.

IF I WAS SEEING YOU, IT'D BE PROOF IT WAS ALL REAL.

BECAUSE YOU HAD THE EXCUSE OF BEING MESSED UP IN THE HEAD. I **DON'T**.



BUT I **DON'T** SEE YOU, DO I?

IT'S BEEN THREE WEEKS SINCE YOU DIED, AND I DON'T SEE YOU AT ALL, BRINK.

SISTER MATH  
THE RABBIT HOLE 60%

FERMI PAB



Boilerhouse district



YOU'RE LATE.

RIOTS. HSD CLOSED THE LOOP.

I HEARD. THAT'S THE FEVER. IT'S PROTECTING ITS OWN.

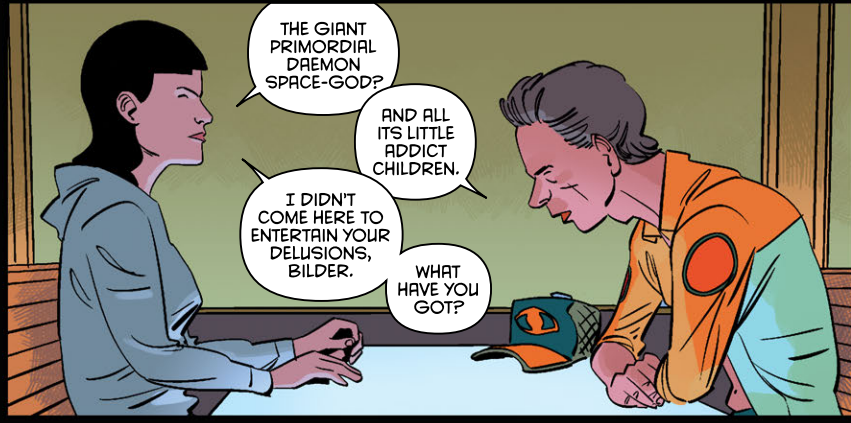

THE GIANT PRIMORDIAL DAEMON SPACE-GOD?

AND ALL ITS LITTLE ADDICT CHILDREN.

I DIDN'T COME HERE TO ENTERTAIN YOUR DELUSIONS, BILDER.

WHAT HAVE YOU GOT?

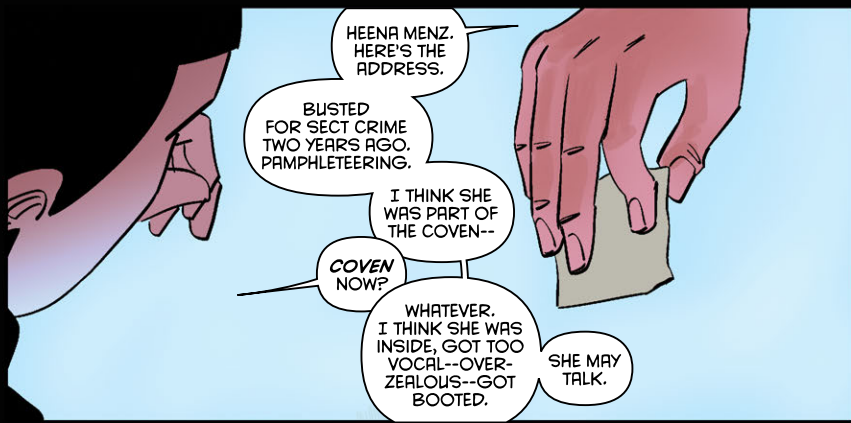

HEENA MENZ. HERE'S THE ADDRESS.

BUSTED FOR SECT CRIME TWO YEARS AGO. PAMPHLETEERING.

I THINK SHE WAS PART OF THE COVEN--

COVEN NOW?

WHATEVER. I THINK SHE WAS INSIDE, GOT TOO VOCAL--OVER-ZEALOUS--GOT BOOTED.

SHE MAY TALK.

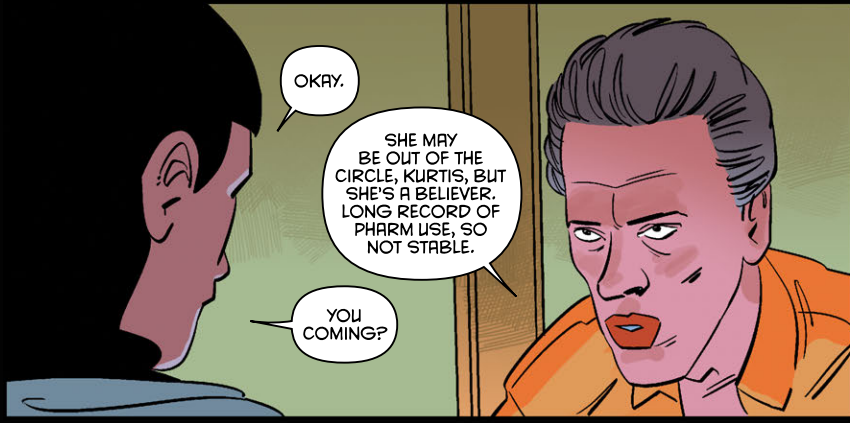

OKAY.

SHE MAY BE OUT OF THE CIRCLE, KURTIS, BUT SHE'S A BELIEVER. LONG RECORD OF PHARM USE, SO NOT STABLE.

YOU COMING?

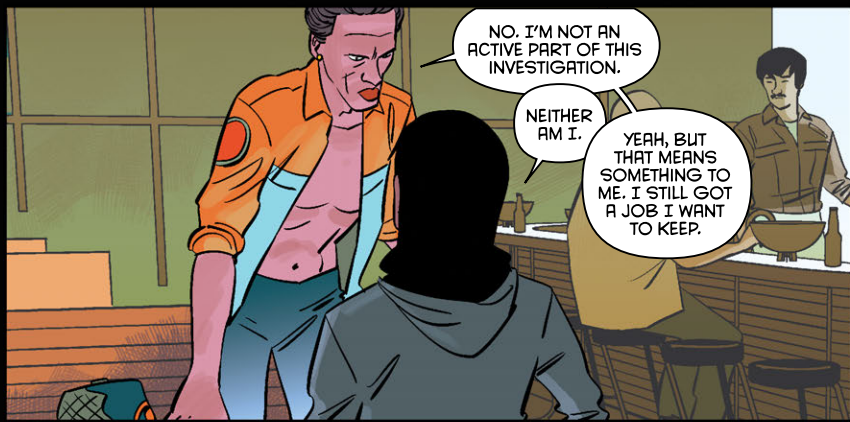

NO. I'M NOT AN ACTIVE PART OF THIS INVESTIGATION.

NEITHER AM I.

YEAH, BUT THAT MEANS SOMETHING TO ME. I STILL GOT A JOB I WANT TO KEEP.





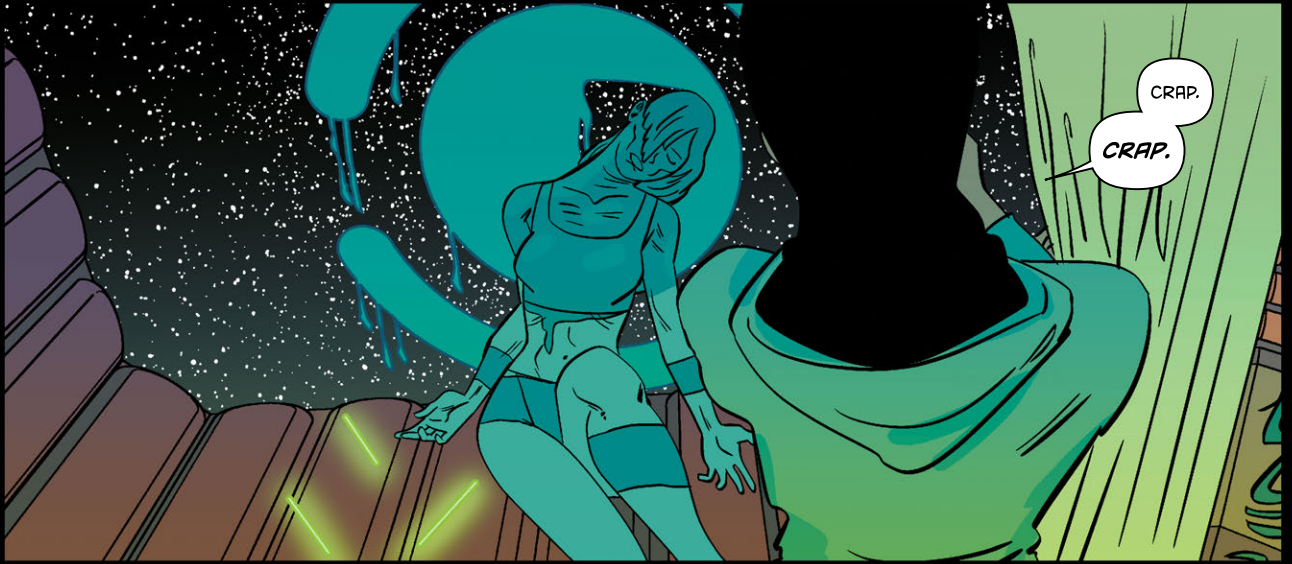



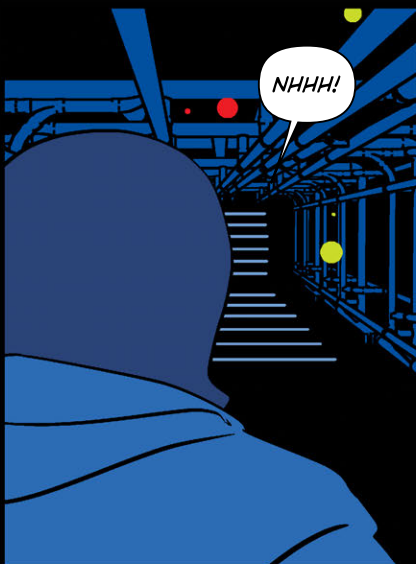



NFF!

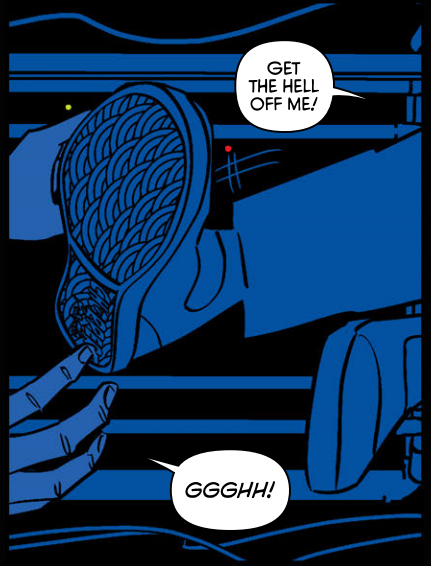

GET THE HELL OFF ME!

GGGHH!



AAAAH!

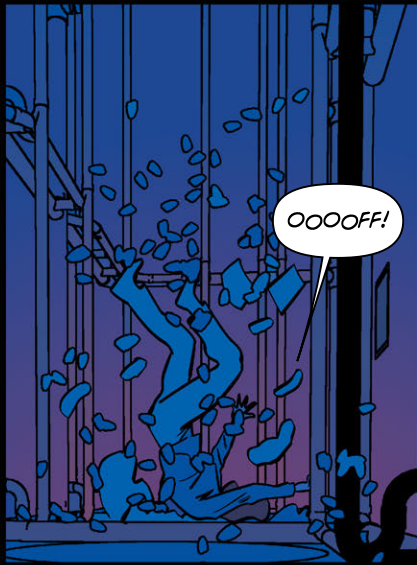

OOOOFF!



>HNH<  
>HNH<  
>HNH<





JESUS CHRIST.



OH DAMMIT.



WHOEVER YOU ARE, STAY BACK!  
STAY THE HELL BACK!



THE  
LEPER HEART  
KNOWS YOU,  
LADY!



IT KNOWS  
WHAT YOU  
DID!



AAAAHH--!



SHIT!

IT NEEDS  
YOU TO PAY  
NOW!

THE UNREACH WANTS  
TO TAKE YOU DOWN  
INTO ITSELF, FOR  
LOOKING TOO DEEP  
AND TRYING TO TAKE  
AWAY ITS TRUTH!



LOW THETA  
WAITS FOR  
YOU IN THE  
HEART OF  
THE SUN.



STAY  
THE HELL  
BACK!

I WILL  
SHOOT  
EVERY ONE  
OF YOU!



YOU AIN'T  
GOT THE  
ROUNDS,  
LADY.

CLIP OF  
EIGHT? NINE,  
MAX.

THERE ARE  
THOUSANDS  
OF US.



THAT'S STILL  
NINE OF YOU  
MOTHERS  
DEAD.

AND ME  
WITH A HEAD  
START.



TO  
WHERE?

EARTH'S  
GONE. HOME'S  
GONE. THERE'S  
NOWHERE LEFT  
TO RUN TO.



Ambi-grav emitter node.



I'LL FIND SOMEWHERE.



YAAAAHHH!!



Grav-normal zone.



ADLER?

THE HELL ARE YOU DOING DOWN HERE?

SAVING YOUR LIFE, LOOKS LIKE.

COME ON.



I DON'T UNDERSTAND. THIS IS A SUMP LEVEL. DEAD SPACE. I--

ALL OF BOILERHOUSE AND BOLO HAS GONE UP IN A RIOT. THE SECTS.

I TOOK COVER DOWN HERE. I HEARD YOUR VOICE.



NO YOU DIDN'T. THAT'S CRAP.

OKAY! OKAY.

I WAS WATCHING YOU. WE'VE RIGGED CAM-SURV RIGHT THROUGH THIS SECTION.

WE SHELTER DOWN HERE WHEN THINGS GET ROUGH.



WHO'S WE?

NORMAL PEOPLE.

PEOPLE WHO AREN'T OUT OF THEIR FRIGGING MINDS ON NUDGE OR TWISTED BY CULT BULLSHIT.



COME THROUGH. I'LL LOCK US BACK DOWN.

ADLER, YOU--

JUST GET IN.



YOU FOUND HER THEN, BOB?



WHO ARE YOU?

THAT'S ANISH. ANISH ANOOR.

NAME'S FAMILIAR...

IF YOU KNOW ANYTHING ABOUT DEEP-RANGE PROPULSION SYSTEMS, ANISH IS A *DRIVE DESIGNER*. AN INNOVATOR. THE BEST.



WAS, BOB. WAS.



YOU TALKED ABOUT HIM IN YOUR SEMINARS. YOU WATCHED THOSE?

ON GURU-TUBE. ALL OF THEM.

AND?

YOU MAKE A STRONG CASE FOR EXTRA-SOLAR MIGRATION, AND THE INVESTMENT NEEDED TO DO IT.



I TOLD YOU SHE'S SYMPATHETIC.

I COULDN'T JUST LET HER DIE OUT THERE. THE CULT'S ALREADY OFFERED HER PARTNER.

OKAY.

I SAID *STRONG*. I DIDN'T SAY I WAS CONVINCED. IF IT WAS SUCH A BRILLIANT IDEA, THE CORPS WOULD BE INVESTING, DEVELOPING...



AND LOSE THE ABSOLUTE CONTROL THEY HAVE HERE ON THE BRINK? BIG FISH, SMALL POND SYNDROME.

WHATEVER.



WHAT IS THIS PLACE?

IT'S A RUSTING SHITHOLE IN THE SUMP OF A ROTTING HABITAT WHERE WE HIDE IN THE DARK FROM THE WORST ASPECTS OF OUR OWN KIND.



AND IT'S WHERE THE *FUTURE* OF THE HUMAN RACE IS GOING TO *START*.

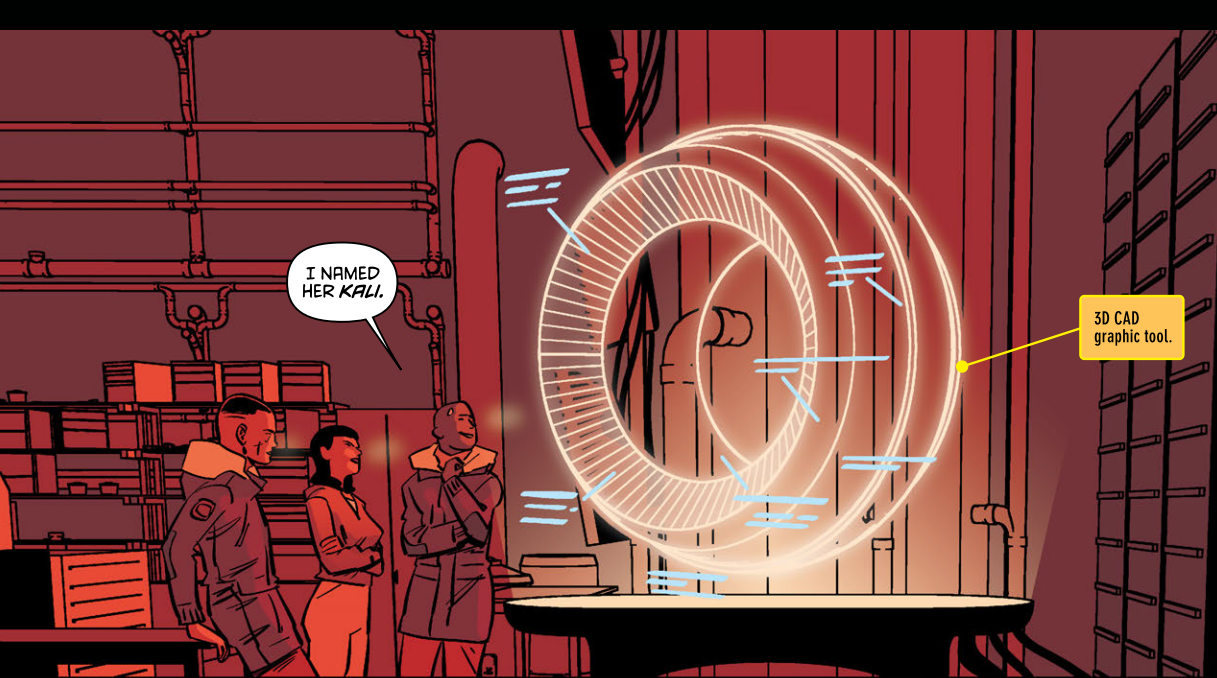

I NAMED HER *KALI*.

3D CAD graphic tool.



"CALLIE"?

NO, *KA-LI*. THE GODDESS OF EMPOWERMENT.

I THOUGHT IT WAS DESTRUCTION.



OH, IN PART. YOU CANNOT CREATE WITHOUT DESTROYING.

THE AGE OF *KALI* IS THE LAST CYCLE OF MAN, BRIDGET. HERE, EVERYTHING WE HAVE BEEN WILL BE DESTROYED.

NICE. A REAL LIPBEAT NAME FOR YOUR PROJECT.

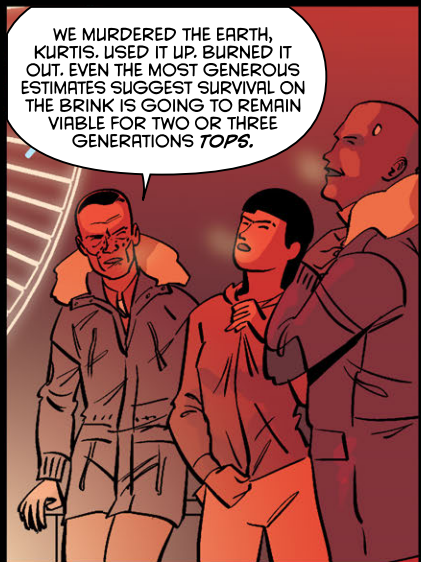

WE MURDERED THE EARTH, KURTIS. USED IT UP, BURNED IT OUT. EVEN THE MOST GENEROUS ESTIMATES SUGGEST SURVIVAL ON THE BRINK IS GOING TO REMAIN VIABLE FOR TWO OR THREE GENERATIONS *TOPS*.



I'D SHAVE ABOUT FOUR DECADES OFF THAT. *MORE*, MAYBE.

THE HUMAN RACE IS LIVING OUT ITS LAST YEARS.

BECAUSE GIANT COSMIC SPACE-GODS ARE GOING TO HATCH OUT AND KILL US ALL?

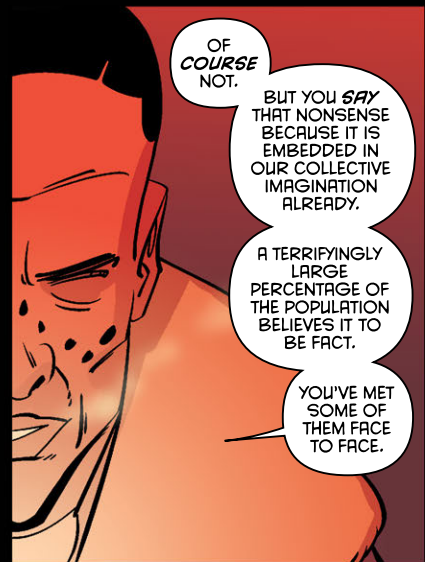

OF *COURSE* NOT.

BUT YOU *SAY* THAT NONSENSE BECAUSE IT IS EMBEDDED IN OUR COLLECTIVE IMAGINATION ALREADY.

A TERRIFINGLY LARGE PERCENTAGE OF THE POPULATION BELIEVES IT TO BE FACT.

YOU'VE MET SOME OF THEM FACE TO FACE.



THAT'S SECT CRAP. MASS PSYCHOSIS.

ABSOLUTELY. BECAUSE THE HUMAN RACE IS GOING MAD.

HAVE YOU HEARD OF *WEIRD LIFE*, BRIDGET?

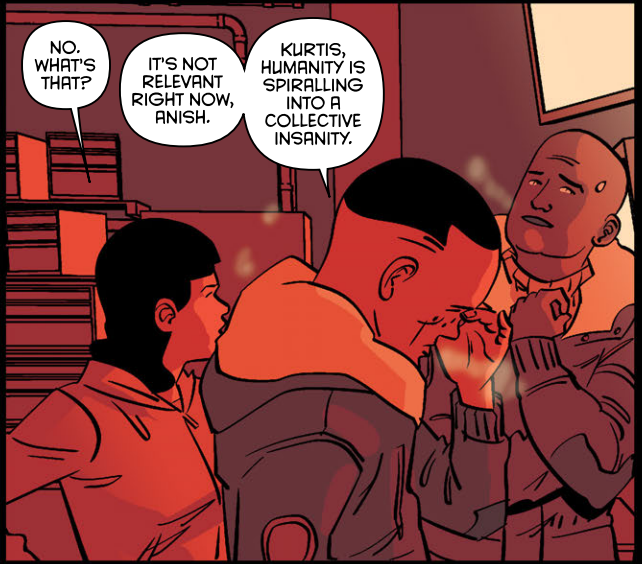

NO. WHAT'S THAT?

IT'S NOT RELEVANT RIGHT NOW, ANISH.

KURTIS, HUMANITY IS SPIRALLING INTO A COLLECTIVE INSANITY.



LONG BEFORE THE SCANT RESOURCES OF THE BRINK DRY UP, WE WILL BE DEAD.

WE WILL SINK INTO THE DELUSIONS OF OUR OWN ADDICTED MINDS AND PERISH.

THE CULTS ARE JUST EARLY ADOPTERS OF THE HYSTERICAL INSTABILITY THAT WILL LEAD TO OUR EXTINCTION.



KALI IS THE WAY OUT. THE WAY FORWARD.

A ZERO-POINT DRIVE SYSTEM THAT WILL CUT OUT-SYSTEM JOURNEY TIMES TO A MATTER OF *MONTHS*.

KALI PUTS *FIVE* HABITABLE EXO-PLANETS WITHIN A THREE-YEAR RANGE.

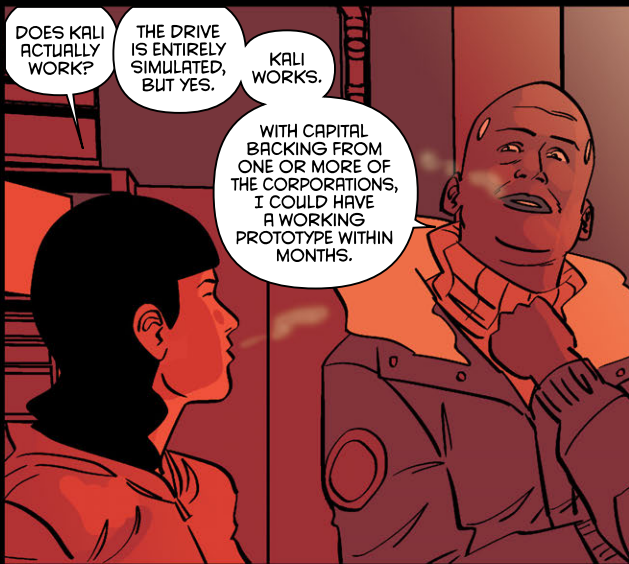

DOES KALI ACTUALLY WORK?

THE DRIVE IS ENTIRELY SIMULATED, BUT YES.

KALI WORKS.

WITH CAPITAL BACKING FROM ONE OR MORE OF THE CORPORATIONS, I COULD HAVE A WORKING PROTOTYPE WITHIN MONTHS.



AND THEN WHAT? A MASS EXODUS?

COLONISATION?

A NEW START ON AN EXO-PLANET OUTSIDE THE SOLAR SYSTEM?



WELL, YES, ESSENTIALLY.

ABSOLUTELY YES.

OH, COME ON...



YOU SEE, THIS IS THE PROBLEM.

YOU ARE AN OPEN-MINDED WOMAN, BRIDGET, AND CLEARLY INTELLIGENT.

YOU SEE THE LOGIC, BUT YOU REFUSE TO CONSIDER THE ACTUALITY.

BECAUSE IT'S A HUGE STEP.



OF COURSE IT IS.

I MEAN, LOGISTICALLY... NOT EVERYONE COULD GO, I ASSUME?

SO WHO GETS TO CHOOSE?

HOW DO YOU MAINTAIN PEACE BETWEEN APPROVED COLONISTS AND REJECTED APPLICANTS?

AND POLITICALLY--



IT IS THE AGE OF KALI, KURTIS. PEOPLE *WILL* DIE.

PUTTING MANKIND ON A NEW WORLD WILL COST LIVES. PERHAPS EVEN WAR ACROSS THE BRINK.

YOU CANNOT CREATE WITHOUT DESTROYING.

BUT BETTER CREATION FROM DESTRUCTION THAN MERE DESTRUCTION ALONE.

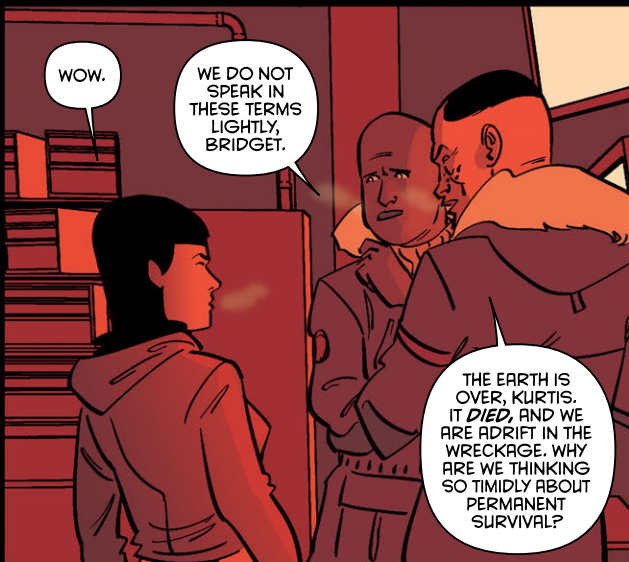

WOW.

WE DO NOT SPEAK IN THESE TERMS LIGHTLY, BRIDGET.

THE EARTH IS OVER, KURTIS. IT *DIED*, AND WE ARE ADRIFT IN THE WRECKAGE. WHY ARE WE THINKING SO TIMIDLY ABOUT PERMANENT SURVIVAL?



WHAT'S *SHE* DOING HERE?

FRANNIE?

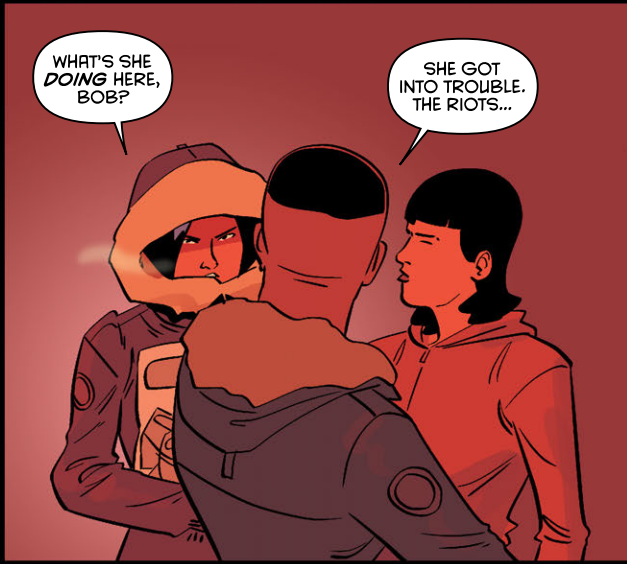

WHAT'S SHE DOING HERE, BOB?

SHE GOT INTO TROUBLE. THE RIOTS...



ARE YOU ALL RIGHT?

SAFE ENOUGH HERE, I THINK.

YOU'RE PART OF THIS?



BOB AND ANISH ARE MY FRIENDS. I BELIEVE IN THEIR PROPOSITION.

WE CAN'T LIVE LIKE THIS.



I BROUGHT FOOD. THE TUNNELS WERE CRAWLING WITH SECT LUNATICS.

THERE'S A BIG FIRE IN BOLO TOO. THEY'RE HAVING TO LOOK DOWN THE LOOP HATCHES.

THE DOWNWARD SLIDE BEGINS.

WE'VE BEEN SLIDING FOR YEARS.



ANYWAY, I BROUGHT FOOD.

THERE'S PROBABLY ENOUGH FOR BRIDGET.



I WAS SORRY TO HEAR ABOUT BRINKMANN.

I... THANKS.

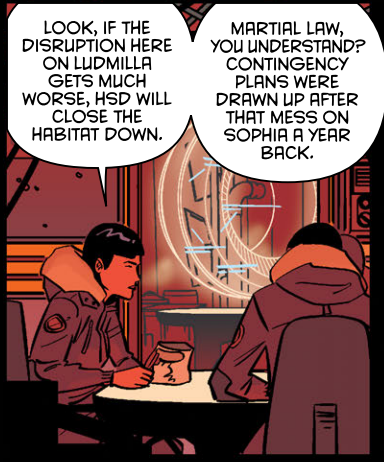

LOOK, IF THE DISRUPTION HERE ON LUDMILLA GETS MUCH WORSE, HSD WILL CLOSE THE HABITAT DOWN.

MARTIAL LAW, YOU UNDERSTAND? CONTINGENCY PLANS WERE DRAWN UP AFTER THAT MESS ON SOPHIA A YEAR BACK.



THAT WAS JUST THE START OF IT. THE FIRST REAL *REVELATION* OF SECT MADNESS.

I HAD HOPED THE AUTHORITIES MIGHT START TAKING ACTION *THEN*.



AND GREENLIGHT A MIGRATION PROGRAMME? IT WAS *CIVIL UNREST*, FRANNIE.

JUST LIKE THE CRAP GOING ON HERE.

I'M SAYING THINGS COULD GET TOUGH. LUDMILLA COULD BE SHUT DOWN. QUARANTINED.



GOOD.

WHAT THE HELL DO YOU MEAN, "GOOD"?



CIVIC COLLAPSE ON A HABITAT WILL *FORCE* THE CORPORATIONS TO ACT.

THE CORPS ARE LIKE PARASITES. THEY LIVE HAPPILY--*PROSPER*-- ALL THE WHILE THEIR HOST BODIES REMAIN HEALTHY.

IF THE GENERAL POPULATION BEGINS TO DECAY INTO LAWLESSNESS, THE CORPS WILL NEED TO RESPOND IN ORDER TO SURVIVE.

A NEW FOUNDATION ON A FRESH WORLD WILL SEEM *MUCH* MORE DESIRABLE AND LUCRATIVE IF THE CAPTIVE MARKET HERE STARTS DYING.

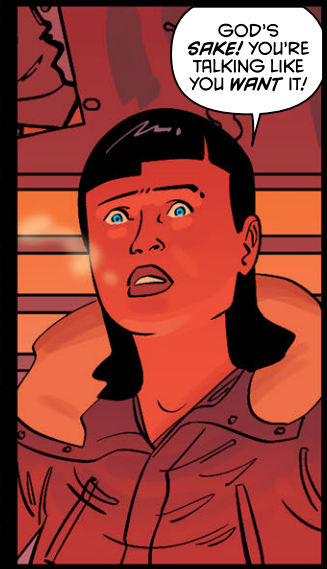

GOD'S *SAKE!* YOU'RE TALKING LIKE YOU *WANT* IT!



WE DO.

YOU'VE TOLD HER A LOT. DIDN'T YOU TELL HER THAT?

WE DO.

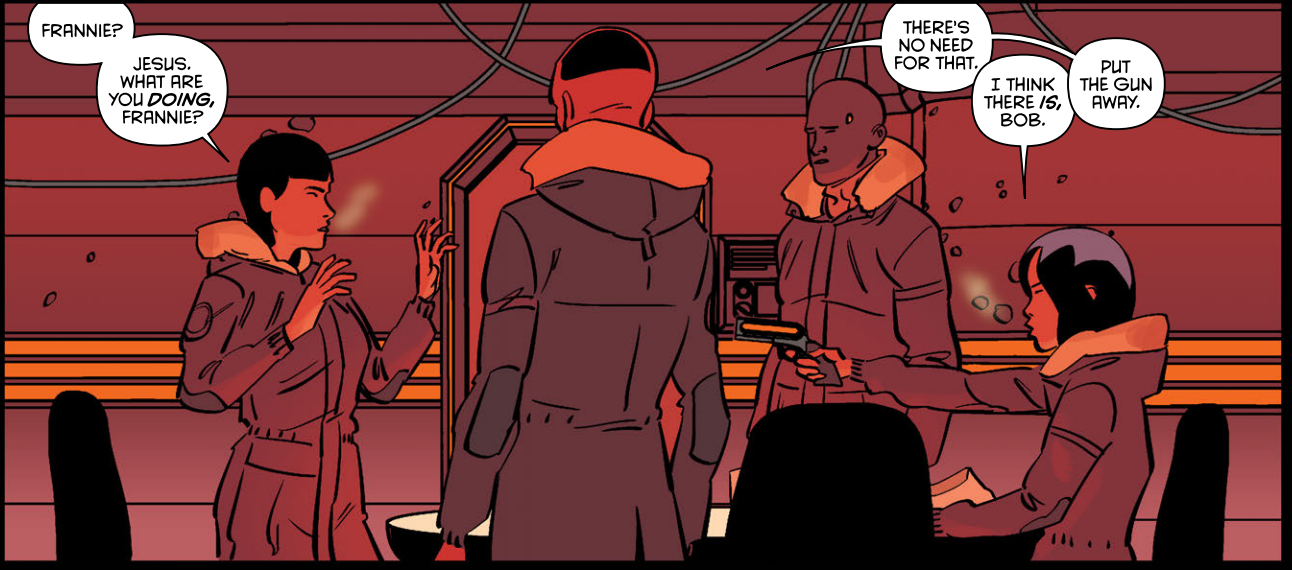

FRANNIE?

JESUS.  
WHAT ARE  
YOU *DOING*,  
FRANNIE?

THERE'S  
NO NEED  
FOR THAT.

I THINK  
THERE *IS*,  
BOB.

PUT  
THE GUN  
AWAY.



I THINK  
WE *NEED* ME  
TO HAVE A  
GUN, BOB.

YOU  
REALLY  
DON'T.



SHE'S  
HSD.

SHE'S AN  
INVESTIGATOR. SHE  
*INVESTIGATES*.

YOU THINK  
SHE WOULD  
LIP DOWN  
HERE IN THE  
BILGE BY  
*ACCIDENT*?



SHE'S  
INVESTIGATING  
*US*.

I'M  
REALLY  
NOT.

PUT  
THE GUN  
DOWN.



WELL, IF  
SHE WASN'T,  
FRANNIE, SHE  
IS *NOW*.



YEAH,  
WELL.

WE CAN'T  
BE TOO  
CAREFUL.

I THINK SHE'S  
GOOD. A GOOD  
INVESTIGATOR.

REALLY,  
*REALLY*  
GOOD.



I THINK SHE'S ALL SMILES AND FRIENDLY, BUT DEEP DOWN, SHE'S THINKING *ALL* THE TIME.

I *AM* REALLY GOOD.

BUT I NEVER THOUGHT *THIS* CRAZY UP.



SHE'S GOT A GUN. BACK OF HER WAISTBAND.

TAKE IT OUT, BRIDGE. REALLY, REALLY SLOWLY.

PUT IT ON THE TABLE.

OKAY.



ON THE TABLE.

I LIKE YOU, BRIDGET.

BUT YOU WERE GETTING *EVER* SO CLOSE.

EVER SO.

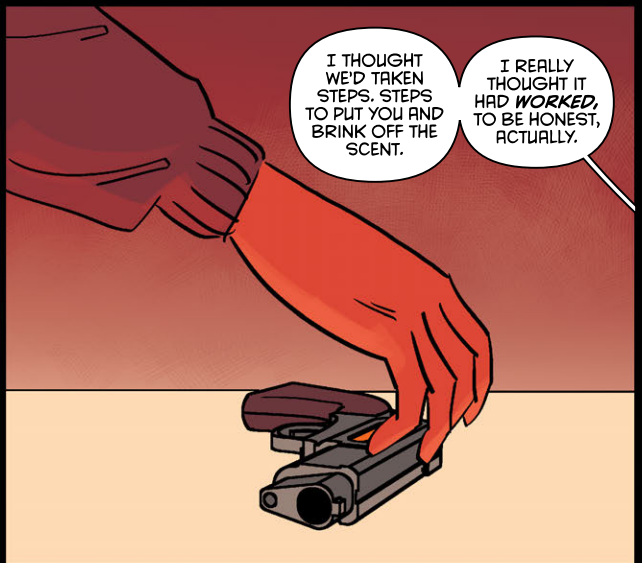

I THOUGHT WE'D TAKEN STEPS. STEPS TO PUT YOU AND BRINK OFF THE SCENT.

I REALLY THOUGHT IT HAD *WORKED*, TO BE HONEST, ACTUALLY.



WITH HIM ALL DEAD AND EVERYTHING.

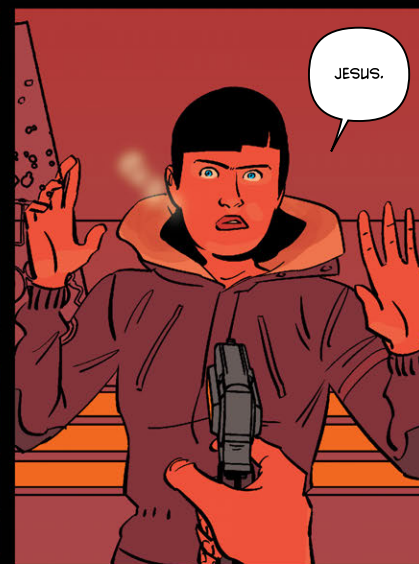

JESUS.



YOU WERE STOOD DOWN. CASE GOES NOWHERE.

NO MORE *INVESTIGATING*.

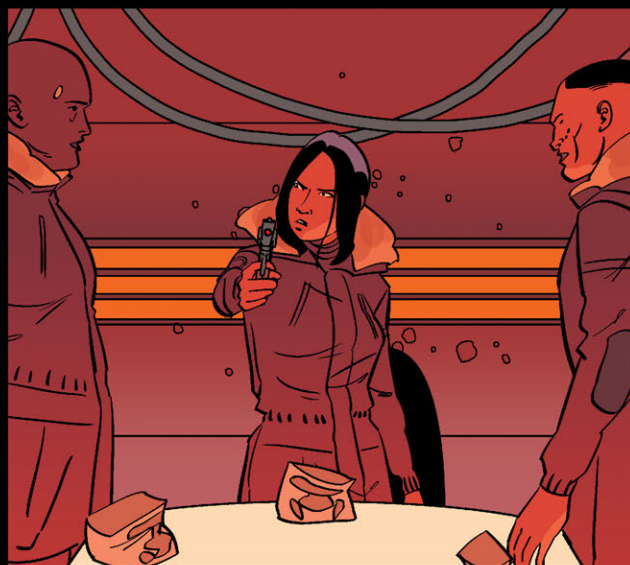



NOT A WORD.



YOU'RE DOCTORING THE HABITAT'S FOOD SUPPLY TO MAKE EVERYONE PSYCHOTIC.

IT'S A **PSYCHOACTIVE**. SYNTHETIC.

**FRANNIE!**

AREN'T YOU?

IT INTERACTS ESPECIALLY WELL WITH MOST OF THE NUDGE BRANDS IN COMMON USE.



OH, DON'T LOOK AT ME LIKE *THAT*, BOB!

SHE **KNOWS!** SHE WON'T HELP US NOW.

I'M GOING TO HAVE TO USE THIS GUN AND--

GIVE IT TO ME, FRANNIE.

GIVE THE GUN TO ME.



LISTEN TO HIM, FRANNIE. GIVE BOB THE GUN.



THANK GOD.



FRANNIE'S QUITE... DELICATE.

SHE CAN SOMETIMES MESS UP WHEN UNDER PRESSURE.

LIKE PULLING A GUN ON ME?



LIKE ACTUALLY SEEING SOMETHING THROUGH.

OH JESUS CHRIST, BOB--



SORRY. THOUGHT WE COULD BRING YOU IN, BUT THAT SHIP'S SAILED.

SHUT UP, FRANNIE.

ANISH, GET SOME PLASTIC SHEETING AND SPREAD IT OUT IN THE LOADING DOCK.

BOB? ARE YOU GOING TO SHOOT HER, BOB?

CAN I WATCH?



TAKE OFF THE COAT.

WHY?

THEY COST MONEY. I DON'T WANT TO GET HOLES IN IT.



YOU KNOW WHAT, BOB? I'VE BEEN OFF NUDGE AND EATING CLEAN SINCE I MET PSYCHO FRANNIE.

WHY AM I STILL SEEING THINGS?

WHAT THINGS?



BRINK.



WHAT DO YOU MEAN, YOU'VE SEEN BRINK?

KURTIS?

I MEAN I'VE SEEN HIM.

SINCE HE DIED.



GET OUT OF THE WAY, ANISH.

ANISH!



BUT YOU'RE NOT ON NUDGE? YOU'VE EATEN MACRO ONLY?

JUST LIKE FRANNIE TOLD ME.

SO WHY AM I STILL SEEING THINGS THAT CAN'T BE?



ANISH, FOR GOD'S SAKE--

GET OUT OF THE WAY, ANISH!



DON'T YOU BOTH SEE WHAT THIS MEANS?

I WAS RIGHT! THERE IS MORE TO THIS THAN PSYCHOACTIVE HALLUCINATION!

WE ARE MESSING WITH THINGS WE DON'T--

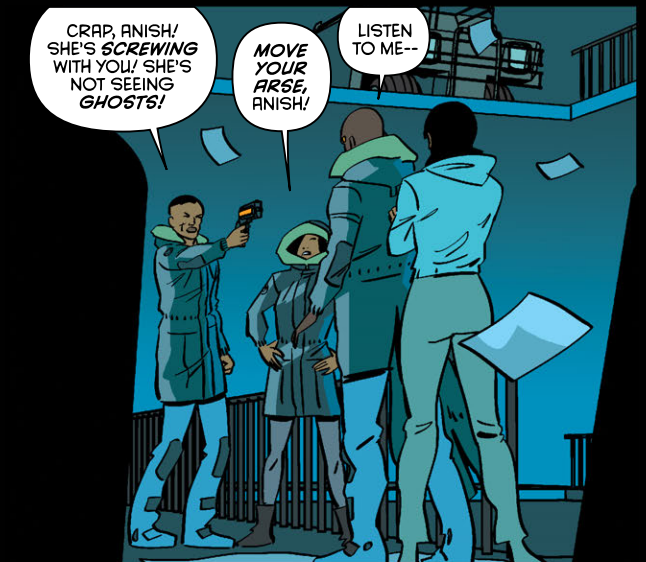

CRAP, ANISH! SHE'S SCREWING WITH YOU! SHE'S NOT SEEING GHOSTS!

MOVE YOUR ARSE, ANISH!

LISTEN TO ME--



I SEE THEM ALL THE TIME.

AHH--!



SHITSAKES, ANISH!

BDAM



UGHHN!



YOU BLOODY HIT ANISH, BOB, YOU STUPID--

GET OFF ME!



SHIT--

AAAAHH!  
AAAAHHH!

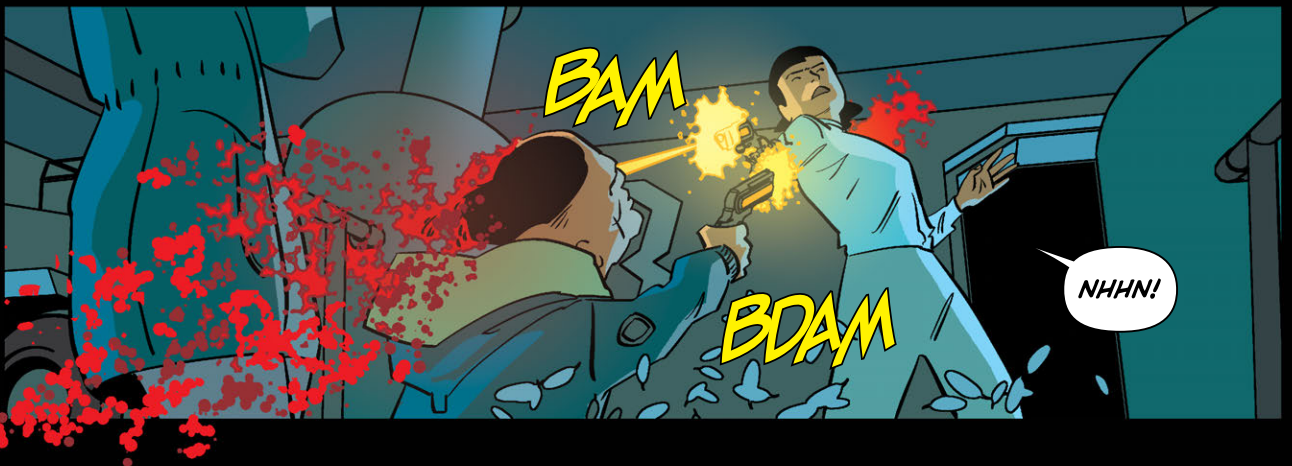
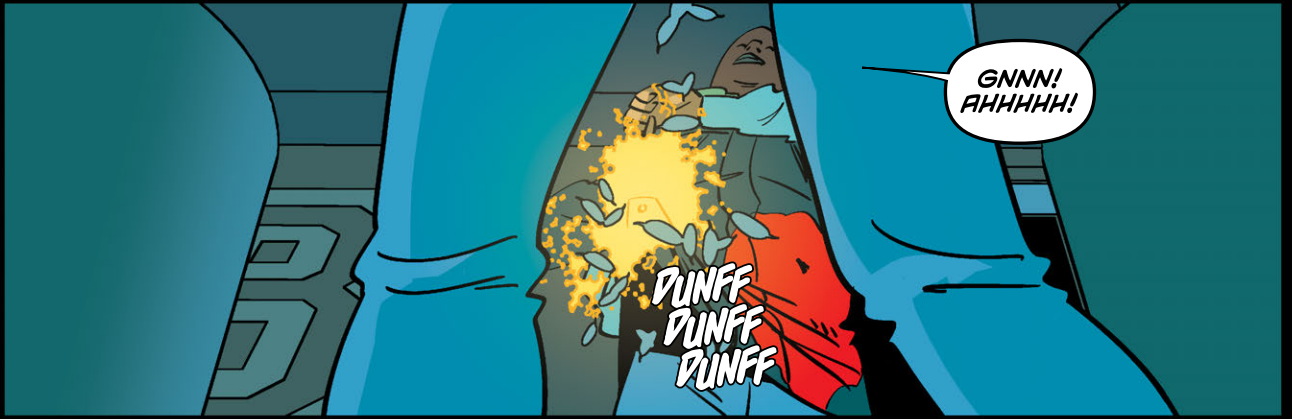



FRANNIE?

NHH!

GET WHERE I CAN SEE YOU, FRANNIE. NOW.

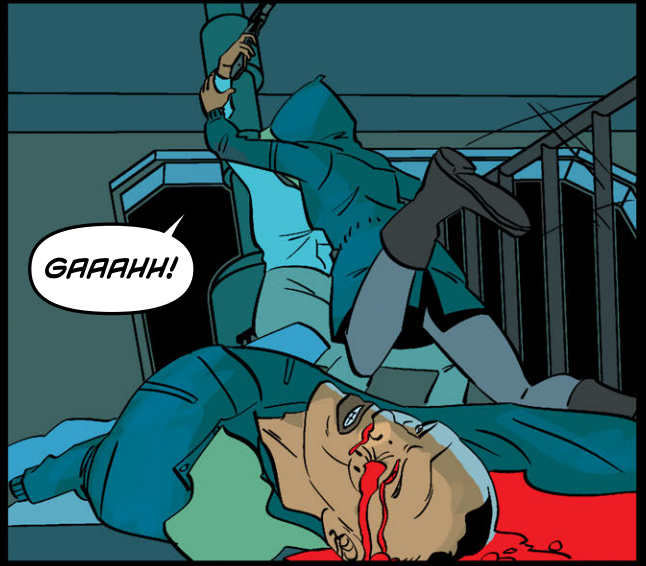

GAAHHH!



UNNF!



UGGH!



->HNN-<

->HNN-<



FRANNIE... DON'T.

YOU SHOT BOB. HE WAS REALLY CLEVER.

YOU SHOULDN'T HAVE SHOT HIM.

HE WAS GOING TO LEAD US OUT OF HERE!

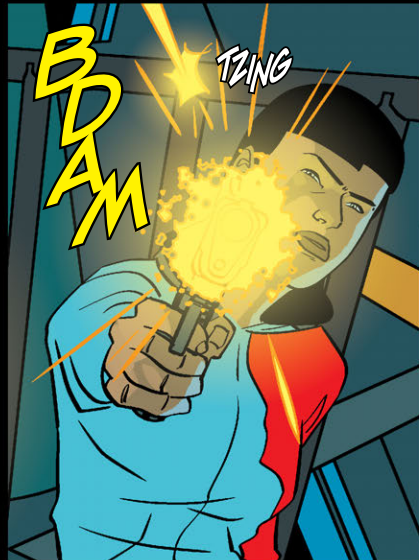

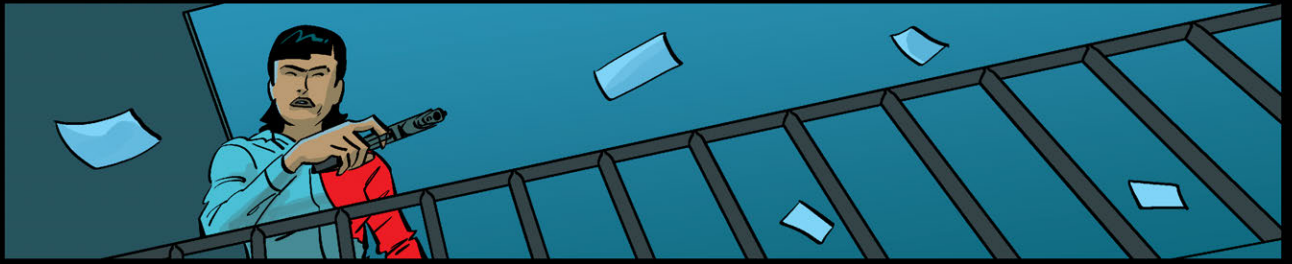

THIS IS  
KURTIS,  
HSD.

CALLING IN A  
NINE-SIX-OH.  
LOCK ON MY  
TRACELET FOR  
LOCATION.

EMT AND  
SOC TEAMS  
**PRIORITY.**



ANISH ANOOR,  
PROPULSION  
ENGINEER?

Уи-иуи.

DRIVE  
DESIGNER.



THE CASE OFFICERS ARE GOING TO WANT TO SECURE ALL HIS WORK PRODUCT AND GET IT REVIEWED BY EXPERTS.

HOW IS HE?

CRITICAL BUT STABLE. HE WON'T BE TALKING TO ANYONE FOR A WHILE, SO, uh--



HAVE YOU HEARD OF "WEIRD LIFE", HASSAN?

I DON'T KNOW.

NO. WHAT IS IT?

SOMETHING ANISH SAID BEFORE IT WENT DOWN. STUCK IN MY MIND BECAUSE HE WAS REALLY POINTED ABOUT IT...



WELL, I DON'T KNOW.

LABWORK HAS ALREADY LOCATED A SYNTHETIC PSYCHOACTIVE CONTAMINANT IN TWO FOOD PROCESSING PLANTS IN BOILERHOUSE.

ANOTHER POSSIBLE IN BOLO.

MATCHES SAMPLES TAKEN FROM THE CRIME SCENE.

SO IT LOOKS LIKE YOU WERE RIGHT--

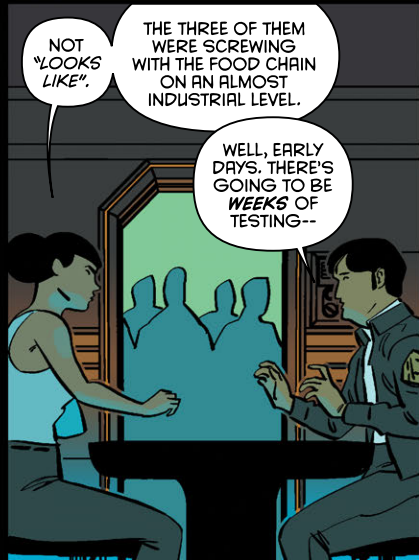

NOT "LOOKS LIKE".

THE THREE OF THEM WERE SCREWING WITH THE FOOD CHAIN ON AN ALMOST INDUSTRIAL LEVEL.

WELL, EARLY DAYS. THERE'S GOING TO BE WEEKS OF TESTING--



IT'S THE CASE **RIGHT THERE**. CONNECTS TO THE INCIDENTS IN BOILERHOUSE, AND TRACKS ALL THE WAY TO ODETTE.

YOU'RE GOING TO WANT TO SEE WHICH HABITATS LUDMILLA IS EXPORTING FOOD TO, AND ALSO CHECK THE TRAVEL RECORDS OF ADLER, LIGHTMAN AND ANY ASSOCIATES--



WE KNOW HOW TO RUN AN OP, KURTIS.

I'LL LEAVE YOU GUYS TO TALK.



YOU'RE--?

BONNER. REVIEW.

OH YEAH.



WE'RE GOING TO BE TEASING THIS ONE APART FOR A LONG TIME.

CLEARLY ADLER AND LIGHTMAN WERE KEY ACTORS. WE'RE LOOKING INTO THEIR SECT LINKS.

COULD OPEN UP THAT LINE IN A BIG WAY. CERTAINLY GIVES US MASSIVE CAUSE TO SHAKE DOWN THE ADVMU BECAUSE OF THE OVERLAP.



DROP THE OTHER SHOE, BONNER. YOU'RE HERE FOR ME, NOT THE CASE.

OKAY. YOU WERE ON SUSPENSION. YOU WERE NOT CO-OPERATING WITH THE INQUIRY.

WE BELIEVE YOU OBTAINED AN UNREGISTERED FIREARM.

WE HAVE THREE DEAD-- ROBERT ADLER, FRANCINE LIGHTMAN, HEENA MENZ.

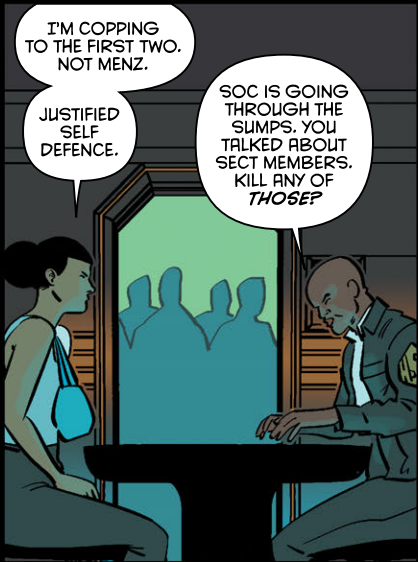

I'M COPPING TO THE FIRST TWO. NOT MENZ.

JUSTIFIED SELF DEFENCE.

SOC IS GOING THROUGH THE SUMPS. YOU TALKED ABOUT SECT MEMBERS. KILL ANY OF *THOSE*?



YOU *UNDERSTAND* WHAT THEY WERE DOING, RIGHT?

LIGHTMAN AND ADLER? AND ANOOR?

YOU UNDERSTAND THEY WERE INVOLVED IN A CONSPIRACY TO UNDERMINE STABILITY ON THIS HABITAT, AND THAT'S LED TO *FOUR* DEATHS I KNOW OF?



POISONING THE FOOD?

YOU'VE GOT LABWORK.

AND YOU THINK THAT UNDERPINS THE WILDFIRE DISTURBANCE HERE?



DON'T *YOU*?

I THINK IT'S A NEAT AND TIDY HAPPY-EVER-AFTER ANSWER. I THINK THE SECT ACTIVITY IS BIGGER, STRANGER AND MORE *COMPLEX* THAN--

SO WHAT?



THIS IS THIS, AND THE REST IS *WHAT*?

THE MALEVOLENT INFLUENCE OF GIANT PRIMORDIAL *SPACE-GOD DEMONS* THAT ARE GOING TO HATCH OUT OF THE SUN?

WHICH IS AN *EGG*?

*THAT* THE EXPLANATION YOU'RE MORE COMFORTABLE WITH?



YOU SAY THAT LIKE IT'S A JOKE.

WHICH, NATURALLY, IT IS. JUST NOT A FUNNY ONE.

SO WHY IS THERE SOMETHING IN YOUR TONE THAT SUGGESTS YOU DON'T THINK IT'S A JOKE?

MY TONE?

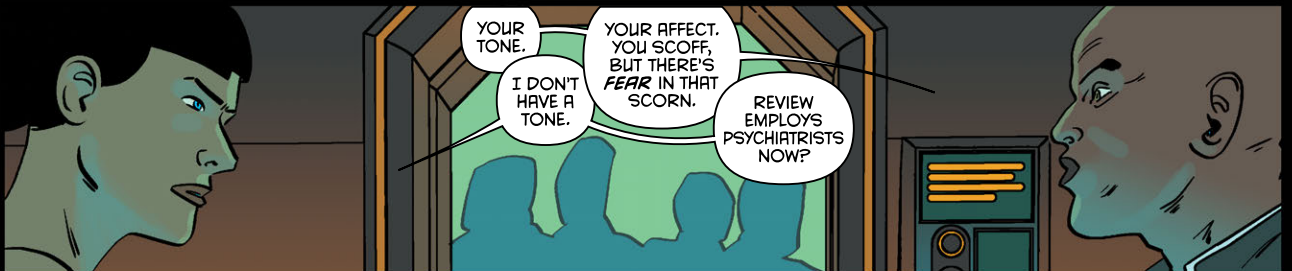

YOUR TONE.

I DON'T HAVE A TONE.

YOUR AFFECT. YOU SCOFF, BUT THERE'S *FEAR* IN THAT SCORN.

REVIEW EMPLOYEES PSYCHIATRISTS NOW?



YES, ACTUALLY.

WELL... BRINK.



WE'RE LIVING IN RUSTING AIR-TIGHT TIN CANS ADRIFT AROUND THE LANDFILL THAT USED TO BE OUR HOME.

DIDN'T SEE *THAT* COMING, DID WE?

*NOTHING* IS RIDICULOUS ANY MORE, BONNER. *NOTHING* HAS THE POWER TO *SHOCK*.

NOT ANY MORE.



AH. *THE* BRINK.

YOU MEANT OUR CONDITION OF LIFE.

I THOUGHT YOU WERE REFERRING TO BRINKMANN.



BDIP  
BDIP  
BDIP



WE'LL PICK THIS UP AGAIN SOON.

I'VE GOT TO DEAL WITH THIS.



HASSAN?

WHAT'S GOING ON?

PROBABLY JUST A COMMUNICATIONS PROBLEM...

WHAT IS?



DARK?

SOLAR-FLARE ACTIVITY IN THE LAST HALF HOUR.

MERCURY JUST WENT DARK.

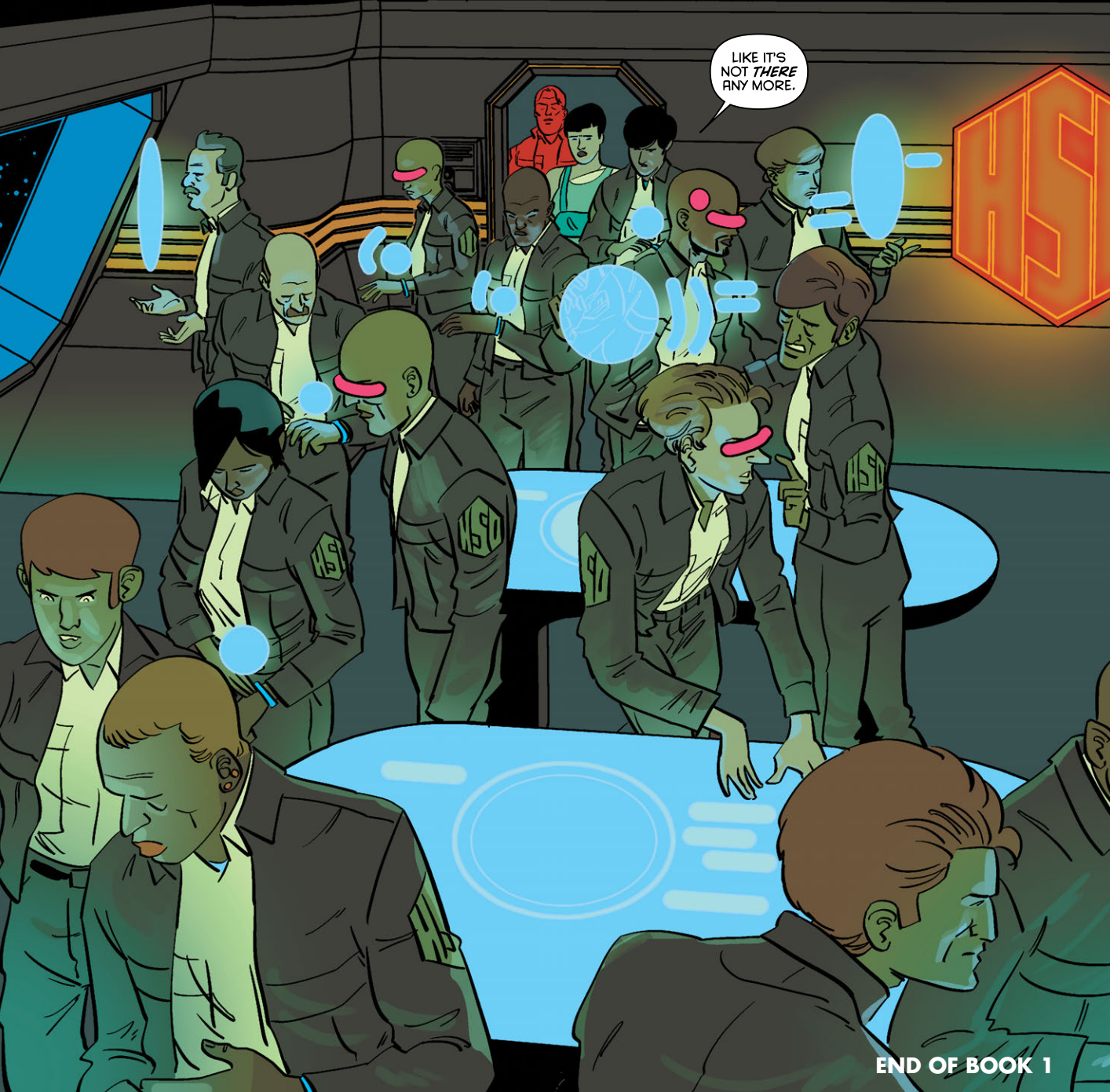

LIKE IT'S NOT *THERE* ANY MORE.

END OF BOOK 1

**COVER GALLERY,  
SKETCHES &  
DAN ABNETT SCRIPT**









ODETTE DESIGN

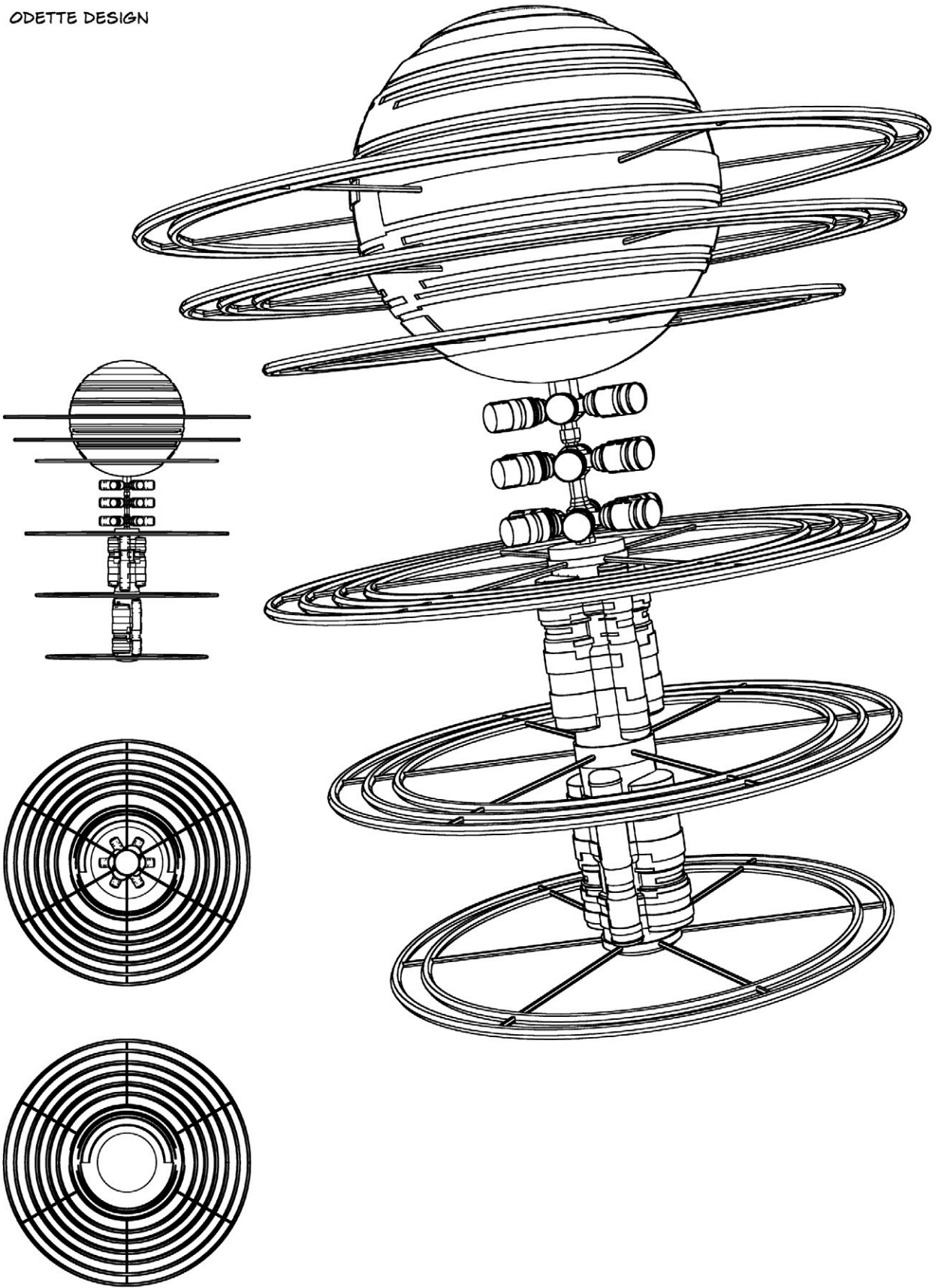

KINO

ZEMKE

ORBITAL

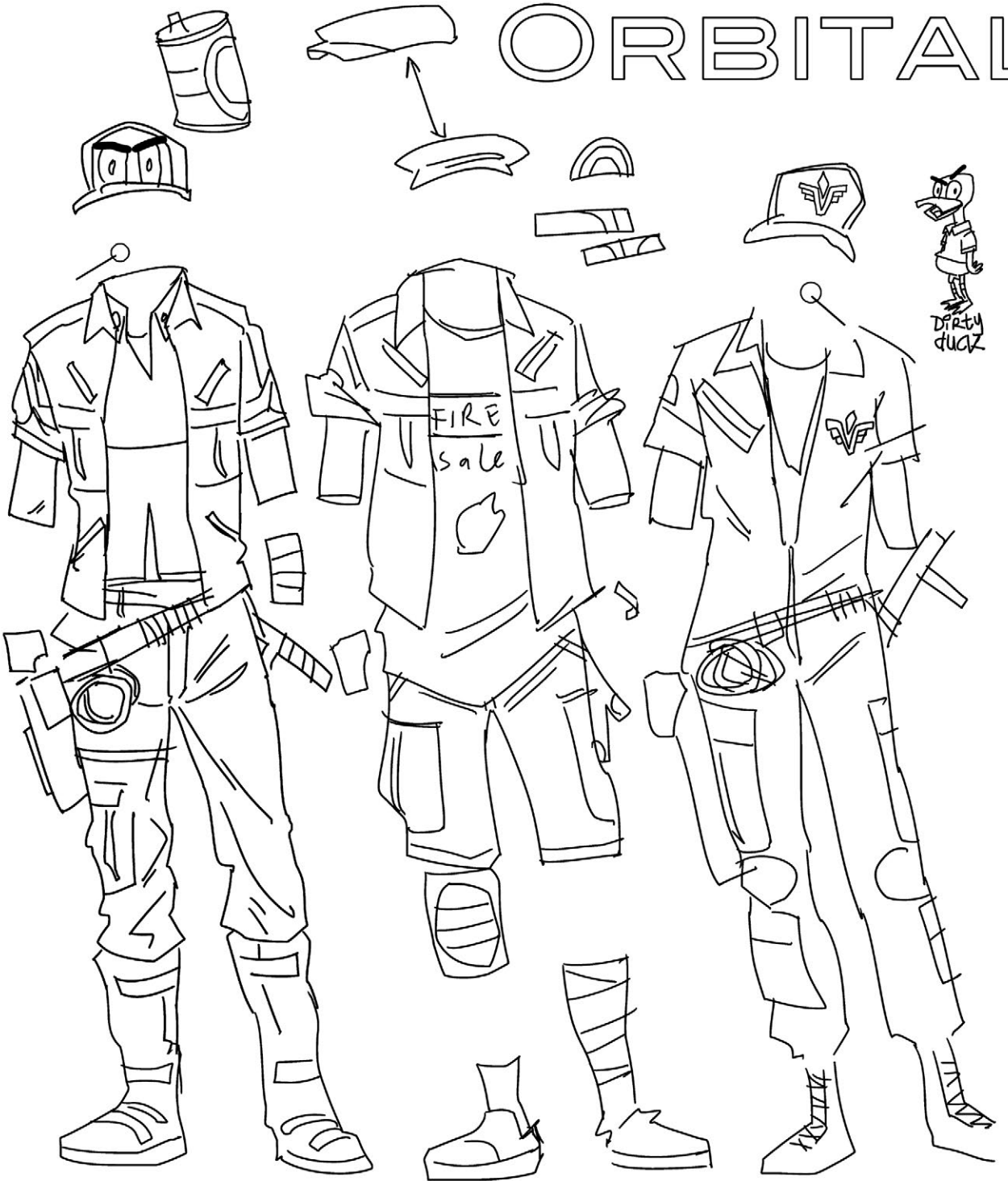

BAR

ON  
ORBITAL NEWS

ON  
NEWS

H  
O  
T  
E  
L  
L  
N  
O  
T  
E  
L  
L  
L

FLESH  
DIT



MACROBIO

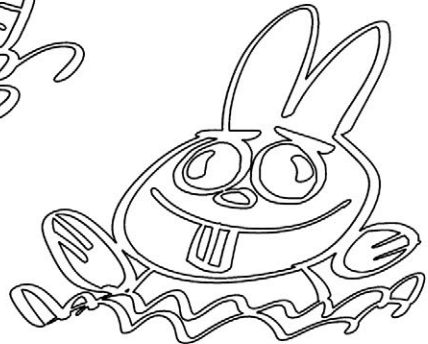

EAT CLEAN

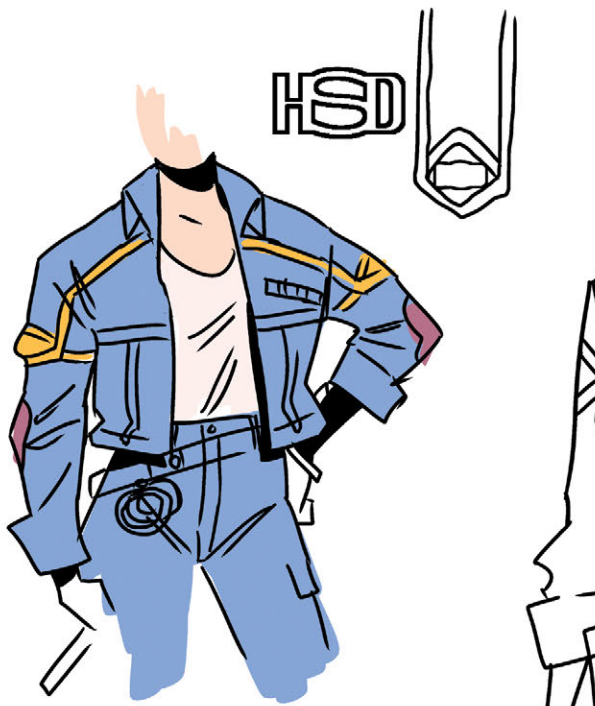

HSD



FIRE  
Sale

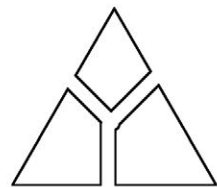
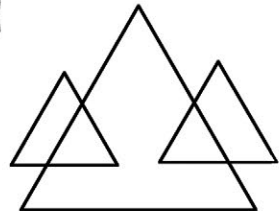

HSD



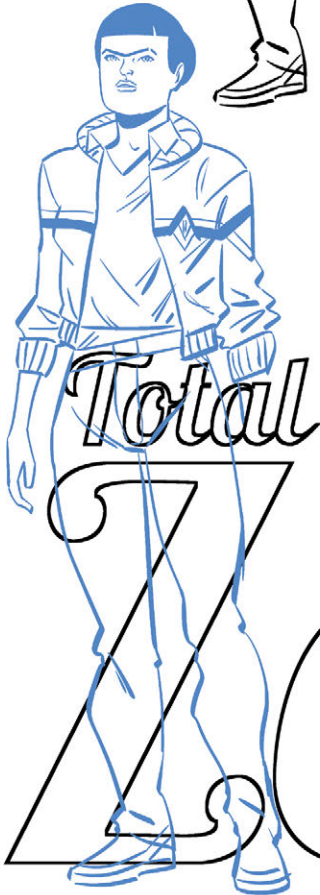
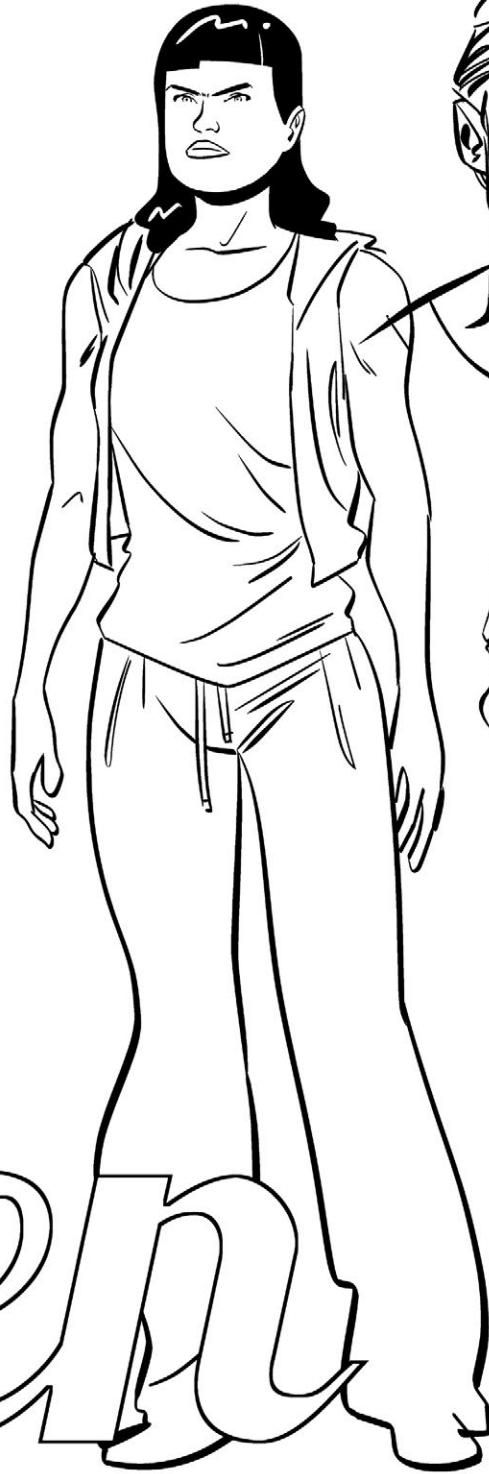

Total

Zen

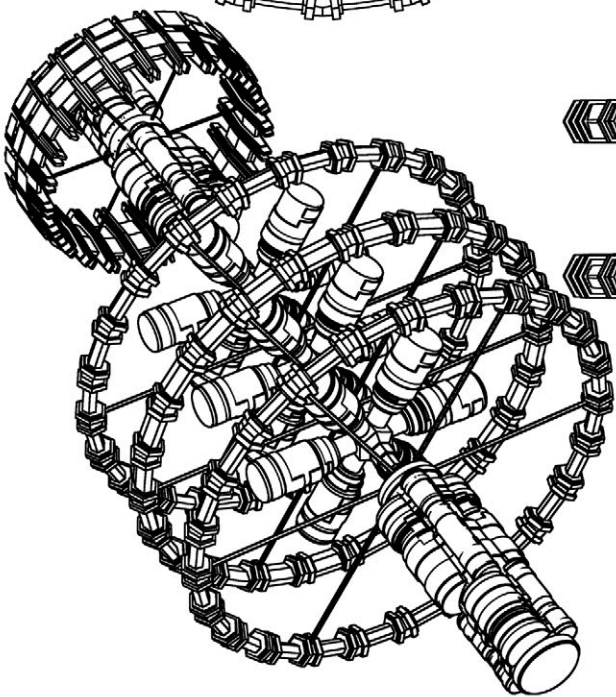
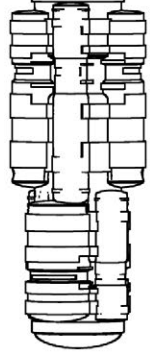
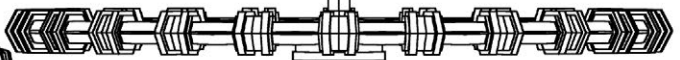
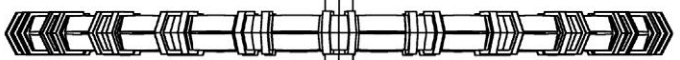
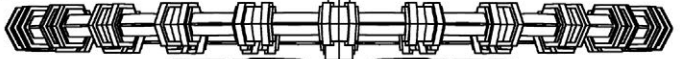
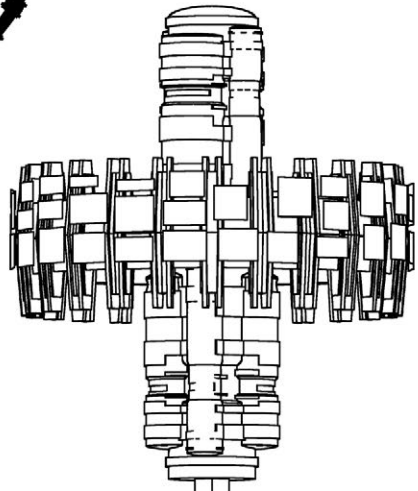
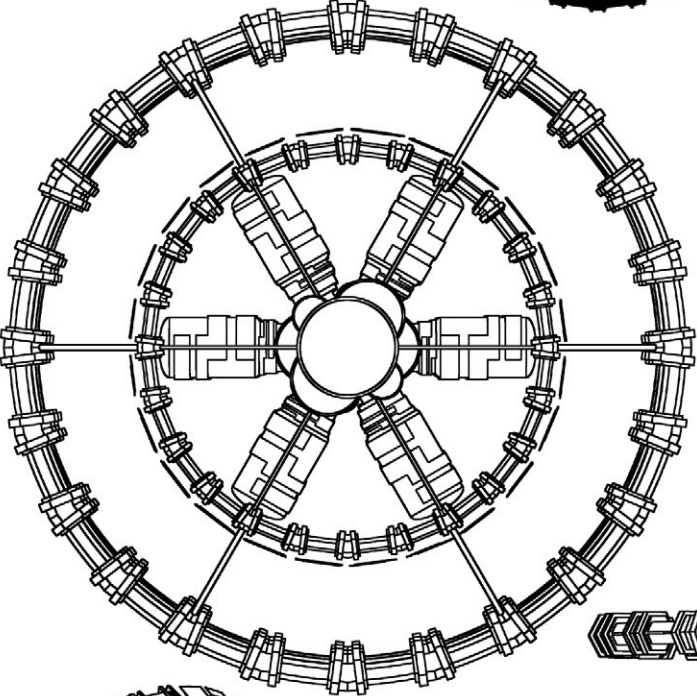
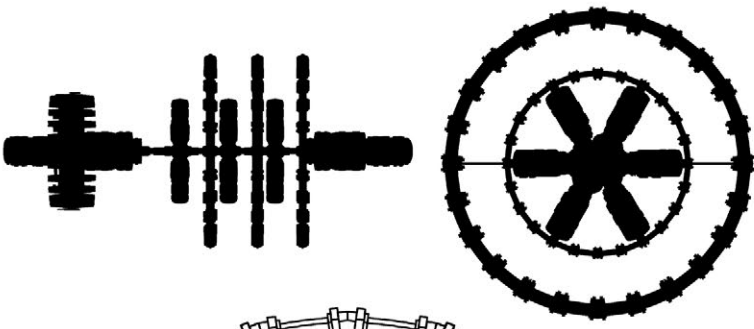

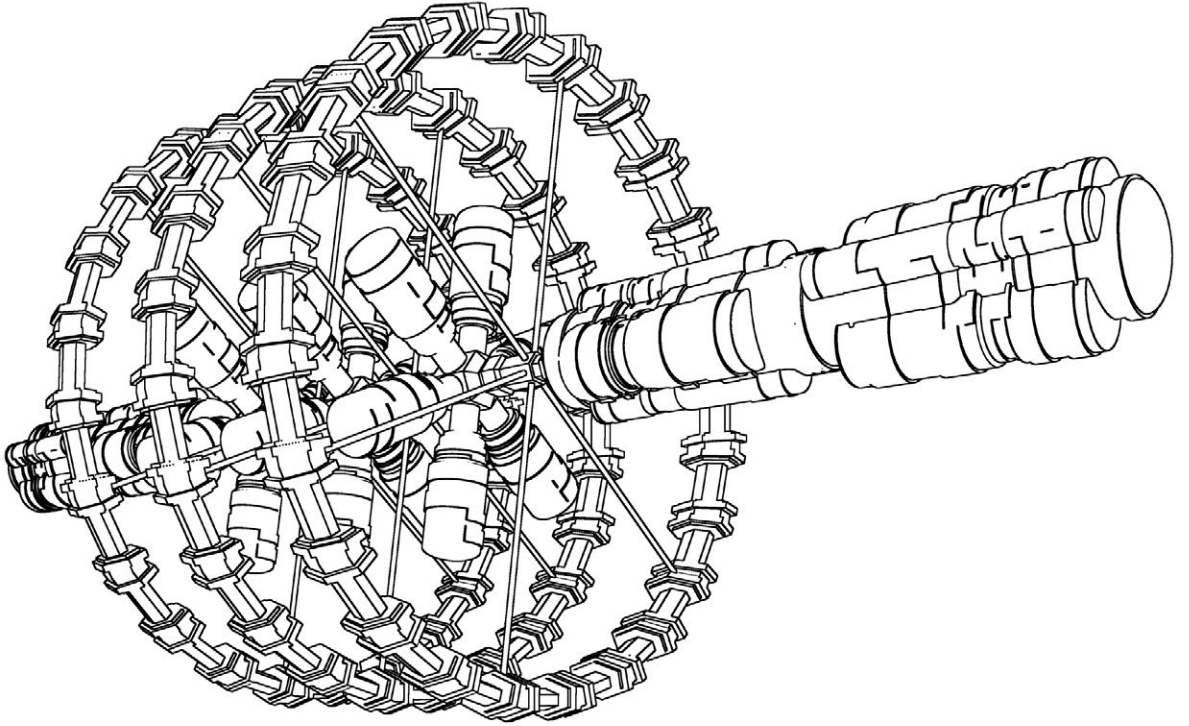

# BRINK: Part One Script

## PAGE ONE

1. Page wide panel. To shock. In a gloomy, artificially lit 'cabin' on a habitat: a personal space, cluttered, mechanical, busy, dirty, worn, like the interior of Soyuz capsule. Junk. Porn pin-ups on the wall. We are looking directly at the head and shoulders of a dead man. What's left of him stares at us, slack-jawed, as if disappointed or bored. Something has bored clean through one side of his face, taking the cheek and the eye, digging a blood-black hole of chewed bone and tissue that goes right through his head. Deliberately, provocatively shocking, like the final shot of Gus in Breaking Bad, or the dead Indian scientist/astronaut in Gravity. He is sitting, propped up. Realistic, messy, human, shocking: not horror movie staged gore, but news-footage clumsy and un-glamorously real.

## NO DIALOGUE

2. Page wide. Reverse angle. BRIDGET and BRINK face us in the doorway, sidearms drawn, but lowering them. Probably a waist up establishing shot. Both should look, at this point, pasty and sick, bad skin, lank hair, like they have flu (everyone looks like that), but they're also horrified by what they see.

Bridge looks like she is trying not to vomit. The dead guy could be in the foreground, facing them. Just for detail, there's a small window port looking out into space in the back wall of the room, opposite the hatch into the common hallway.

**BRINK**

Bridge?

**BRIDGE**

Mmm,yeah.

**BRINK**

Might you be sick?

**BRIDGE**

Nope. Mmm.

## NEW PANEL 3

**BRINK** (FROM OFF)

Let's secure the scene.

**FX**

KLK

**TAG** (to unit)

Environmental ambi-grav setting to 9.807 m/s sq (Earth Normal)

## NEW PANEL 4

**FC**

Splpsh

3. Brink peers at the dead guy, distastefully. Bridge glances around the grubby room.

**BRINK**

Someone opened his face with a machine drill.

4. Brink checks the dead guy's "tracelet", a wristband like a sleek rubber charity wristband. Everyone wears one. Maybe they're all orange. When you tap them, they project a display like an iPhone screen onto the skin of your forearm or the back of your hand. See this: <http://www.gizmag.com/cicret-bracelet/35109/> ...but fully functional. Brink is making it project on the man's hand, but we can't read the display, just the orangy glow of it.

**BRINK**

According to his tracelet, he's Xan Harbin.

5. Bridge is checking her own tracelet, adjusting the display like a touchscreen.

**BRIDGE**

Snap. The caller.

**TAG** (her display)

Harbin, Xan  
inhab 412 loop 343 Odette  
Call of complaint regarding neighbours logged 03:56

6. Brink glances at her. She shrugs.

**BRINK**

Are we going to feel bad for getting here too late?

**BRIDGE**

Yes, Brink. Forever.

**BRINK**

Long time, forever.

**PAGE TWO**

1. Page wide, large shot, exterior, establishing the ODETTE HABITAT, a long chain of clumped together habitat drums and pods, 'weather-beaten' and dirty, hanging in a vast darkness of space, Big in the foreground, trailing away smaller as the chain grows distant. Maybe have some small shuttle docking for scale, or two guys in space suits working on the exterior with welding torches (nowhere near where the voices are coming from).

**BRIDGE** (from)

Not these days.

**TITLE** Brink

**SUB** Episode one

**TAG** (habitat)

Odette Habitat

Owned: Sugarsurf Pharma

Completed: 2076 AD

**TAG** (habitat)

Population: 209,000

First occupied 2077, five years after the final evacuation of Earth

2. Now maybe we're looking in through the grubby window port into the crime scene cabin, seeing them searching.

**TAG** (that cabin)

Habitation compartment 412

Loop 343 Odette

**BRINK**

Check the lockers.

3. Interior, they start to search, opening lockers, moving stained seat cushions etc. She's finding a packet of pills in one of the lockers.

**TAG** (Bridge)

Bridget Kurtis

Investigator, Habitat Security Division

born: Salma Habitat 2067

**TAG** (Brink)

Carl Brinkmann

Investigator, Habitat Security Division

born: Xiang Habitat 2061

**BRIDGE**

Harbin was on double-scrip nudge.

**TAG** (drugs)

High-dose selective serotonin reuptake inhibitor antidepressants

4. From the window side of the room as Bridge shoots a glance at Brink, finger to her lips. Both are moving to cover. Someone's approaching outside.

**FROM OFF**

...that crackwipe Cruz done now? (joined)

I told him to be chill.

5. Match shot, but Bridge and Brink are either side of the door, pressed to the wall, guns drawn

and ready, so neither can be seen by the two men stepping into the room. Both are workers, grubby, very shifty and sick looking. Both stare at the corpse without much reaction except tiredness. One (Bremer) is further into the room than the other (Nold) who is still half-out in the corridor. Both, as an incidental detail, are wearing creepy-weird, home-made necklaces, little 'symbols' of their dark cult. Maybe a star-shaped design, disturbing, which we'll use again. Both maybe wear several, variations of the same, and we don't have to see the detail here.

**BREMER**

Oh, for crap's sake.

(joined)

We're gonna need sheet wrap and access to the waste plant--

6. Match shot as Brink and Bridge both step out, guns aimed. Their guns are dark, blunt functional modern firearms - Sig Sauer pistols blended with Blade Runner's handgun. Retrofitted, solid slug, moulded grips. Bremer freezes in terror, but Nold starts to run.

**BRINK**

Freeze.

(joined)

Security.

**BREMER**

Shit!

**TAG** (gun, either)

.40 SIGlock automatic, H.S.S. field issue flatnose rounds

**PAGE THREE**

1. Continuous. Bridge is bundling the panicking Bremer down hard, arm lock. Brink is flying out the door after the otherone.

**BRIDGE**

Down! Down! Get down!

**BREMER**

Shit! No! Shit!

**BRIDGE**

Get the other one!

2. Exterior, the hallway. Nold sprinting desperately towards us, glancing back, Brink sprinting in pursuit. Other habitat dwellers get out of the way, shrink back, or watch with grim fascination.

**BRINK**

Halt!

(joined, small)

Damn it.

3. Back on Bridge, struggling with the arm-locked Bremer, getting cuffs on him.

**BRIDGE**

Quit it! You're under arrest!

**BREMER**

This ain't the way! This ain't the way!

(joined)

The Leper Heart will see you for what you are! See your disrespect! See your bruises upon my body!

**BRIDGE**

Shut up!

4. Back on Brink. He's vaulting down a metal staircase using the handrails into a filthy, steamy kitchen galley. Nold is already running and barging his way through the workers, knocking them aside, cookpots spilling, etc. Shots, angry complaints.

**TAG** (room)

Loop 343 communal galley

**SHOVED COOK**

Hey! Retard!

5. Continuous. Brink slams through the galley in pursuit, shouting, gun raised high so it isn't aimed at anyone. People are getting in his way (accidentally).

**BRINK**

Security!

(joined)

Move aside!

(joined)

Come on!

6. Back on Bridge, the cuffs now in place. Bremer's still struggling, on his knees, and she having to shove his shoulders down.

**BREMER**

Promises were made! You're spoilng it! The Leper Heart promised!

(joined)

Took the soil and the air, and left us in the dark with a promise it would come back for us too!

**BRIDGE**

Shut the hell up!

**BREMER**

Swelling up, swelling up out of the unreach, keeping its whispered promises!

(joined)

Low Theta, hanging inside the sun, Melancholema, and Phale Chronozon--

**PAGE FOUR**

1. Continuous. Bridge halts, for a second, shocked, suddenly looking very very pasty and unwell.

**BRIDGE**

(small)

Hell did you just say?

**BREMER**

Phale Chronozon!

2. Continuous. She keeps him pinned as before but, involuntarily, vomits violently, either aside onto the deck or (I prefer this) accidentally all over his shoulders and the back of his head.

**BRIDGE**

-WHHHULLPP-

**BREMER**

Gaaah! Jesus, bitch!

3. Cut back to Brink. Kinetic impact shot as he flying tackles the fleeing Nold as they come out of the galley exit onto a metal gantry pavement above a huge engineering space. This impact is painful for both of them. This engineering space is a large chamber, perhaps where two habitat modules join. Below, we can see a curving wall of cabin or apartment windows, showing the density of the living space, a tower block wrapped into a drum. Maybe washing lines loop between the railings and walkways as people use the space for maximum efficiency.

**BRINK**

GRnaaaah!

**NOLD**

Nuuhhhk!

**TAG** (chamber)

Loop 343/Loop 344 junction ring

4. Continuous. They rolling, grappling. A painful frenzy. Brink is throwing a punch that is snapping Nold's head around and slamming it towards the pavement guardrail.

**BRINK**

Enough of your shit!

**NOLD**

Boohkk!

5. Continuous. Driven by the punch, Nold's head ricochets nastily off the railing.

FX

**BLANG!**

6. Panting, sick and out of shape, Brink kneels on (straddles) the very unconscious Nold, trying to cuff him. He's facing us through the guardrail. He doesn't see (but we do) the terrifying figure coming up behind him fast, appearing like LEATHERFACE in TCM.

This is a big guy, filthy, dirty work clothes, wearing a scary rebreather mask from a space suit and maybe some creepy-weird necklaces like Nold and Bremer. He has a massive dirty wrench raised to brain Brink.

**BRINK**

-nnh!- -nhh!- -nhh!-

(joined)

Asshole!

**MASK** (muffled)

Mmmlll Krrmmnnzznnn!

**PAGE FIVE**

1. Brink dives to one side as the wrench comes down and deeply dents, deforms the railing instead of his head.

**FX**

WHUNGG!

**BRINK**

AAAH!

2. Brink is sprawling, trying to raise his sidearm, but the brute swings the wrench and smashes out of his hand, breaking fingers.

**FX**

KRKK!

**BRINK**

Nyaaaghh!

3. Brink falls back, the brute over him. We're looking up at it, from 'over Brink's shoulder' as it raises the wrench to pulp him (and us).

**MASK** (muffled)

Mmmlll Krrmmnnzznnn!

**BRINK**

Son of a--

4. Match shot, but the brute spasms, one of his mask's eye lenses suddenly cracked and full of blood (he's been shot from behind in the back of the head).

**FX**

KBAMMM!

5. Brink looks up, the brute slumped face down across him, heavy and dead, the back of his head a bloody pulp. Bridge is standing back away down the pavement, her sidearm still aimed in a braced, two-handed stance, muzzle smoking.

**BRINK**

Jesus.

(joined)

Thanks.

(joined)

You going to be sick now?

6. He clambers up, letting the body roll aside. In the foreground, she is turning aside, lowering her gun, sagging and fatigued as the tension release shivers through her, looking pale and sick.

**BRIDGE**

No.

(joined)

Nothing left to come up.

**CAP**

Next: case study

## DAN ABNETT

Dan Abnett is a seven-times New York Times bestselling author and an award-winning comic book writer. He has written over fifty novels, including the acclaimed Gaunt's Ghosts series, the Eisenhower and Ravenor trilogies, volumes of the million-selling Horus Heresy series, *The Silent Stars Go By* (*Doctor Who*), *Rocket Raccoon and Groot: Steal the Galaxy*, *The Avengers: Everybody Wants To Rule The World*, *The Wield*, *Triumph: Her Majesty's Hero*, and *Embedded*. In comics, he is known for his work on *The Legion of Super-Heroes*, *Aquaman*, *The Titans*, *Nova*, *Wild's End*, and *The New Deadwardians*. His 2008 run on *The Guardians of the Galaxy* for Marvel formed the inspiration for the blockbuster movie. A regular contributor to the UK's long-running *2000 AD*, he is the creator of series including *Grey Area*, *Lawless*, *Brink*, *Kingdom* and the classic *Sinister Dexter*. He has also written extensively for the games industry, including *Shadow of Mordor* and *Alien: Isolation*.

Dan lives and works in the UK. Follow him on Twitter @VincentAbnett

## I.N.J. CULBARD

I.N.J. Culbard is an award-winning artist and writer. He has had work published by SelfMadeHero, Dark Horse comics, Vertigo and BOOM! Studios. He first started working with Ian Edginton on adaptations for SelfMadeHero of *The Picture of Dorian Gray*, *The Hound of the Baskervilles*, *A Study in Scarlet*, *The Sign of the Four*, and *The Valley of Fear*. He has also worked with Dan Abnett on original series such as *The New Deadwardians* (Vertigo), *Dark Ages* (Dark Horse Comics), and *Wild's End* (BOOM! Studios). And lastly he has worked with Chris Lackey and Chad Fifer on the original graphic novel, *Deadbeats* (SelfMadeHero)

He has produced a number of his own adaptations for SelfMadeHero including *The Case of Charles Dexter Ward*, *The Shadow Out of Time*, *The Dream-Quest of Unknown Kadath*, *At the Mountains of Madness* and his first solo original graphic novel, *Celeste*.



## THE EDGE OF MADNESS!

IN THE LATE 21<sup>ST</sup> CENTURY THE REMAINS OF THE HUMAN RACE ARE CRAMMED INTO the Habitats: vast artificial space stations; hotbeds for crime and madness policed by private security firms. When a routine drug bust goes wrong, no-nonsense Investigator Bridget Kurtis finds herself in a life or death struggle with a new sect of cultists. But evidence begins to point to something far more sinister going on behind the scenes...

The first series of the new atmospheric, sci-fi thriller from Dan Abnett and I.N.J. Culbard.

ISBN 978-1-78108-550-9



9 781781 085509

UK £12.99 US \$17.99 CAN \$24.99



WWW.  
2000AD  
ONLINE  
.COM